



The UPS Handbook

Parallel UPS Systems

7

Parallel UPS Systems

Introduction

Chapters 4, 5 and 6 describe the operation of a stand alone UPS – often referred to as a ‘single module’ UPS installation. However, to maximise the power security and flexibility of a UPS system it is common practice to install a ‘parallel module’ system comprising several UPS modules operating in synchronism with their outputs connected together to provide a common load supply.

The modules forming part of a parallel system are almost identical in operation to that of their single module counterparts. In fact, some manufacturers design their modules such that they can be used as either stand alone or parallel units without the need for complex modification.

The major difference between a ‘single module’ and ‘parallel module’ installation is that a parallel system requires a ‘control bus’ to be connected between the modules to allow them to communicate with each other. The inter-module control functions that are implemented via the control bus typically include:

- frequency control and synchronisation
- output load sharing
- synchronous load transfer

This chapter deals with several aspects of a parallel UPS system design.

First, it describes the functional differences between a ‘capacity’ and ‘redundant’ parallel system, followed by an explanation of ‘centralised’ and ‘decentralised’ system architectures.

Finally, the chapter considers the advantages of a modular UPS system design, and includes several examples of managing such a system.

Capacity Systems

A ‘capacity’ rated UPS system requires every UPS module contained in the system to be fully operational to supply the system’s rated load.

Figure 7.1 shows how three 100kW units might be used to serve a 240kW load, with each module providing 80kW under normal circumstances.

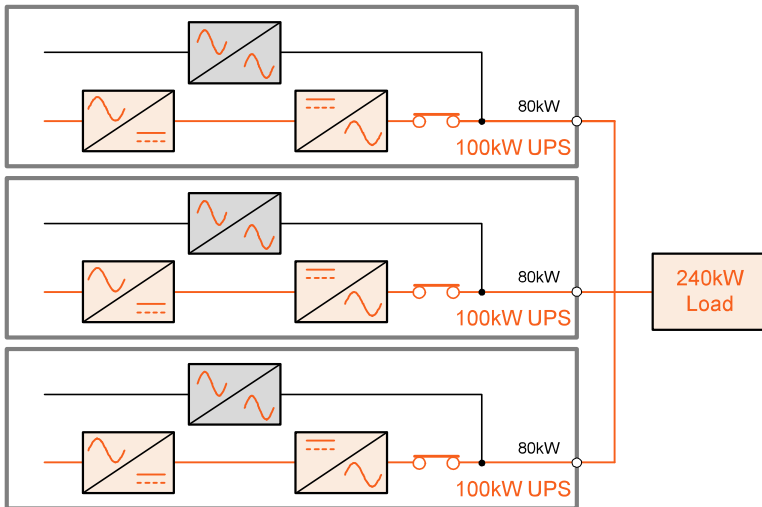

Figure 7.1: Parallel Capacity System – load sharing

If one module fails, the remaining two will each be expected to supply 120kW and would be substantially overloaded. In this situation the load is transferred to the bypass mains supply by the simultaneous operation of the static switch in all three modules, and the load is once again shared at 80kW from the bypass supply as shown in Figure 7.2, on page 98.

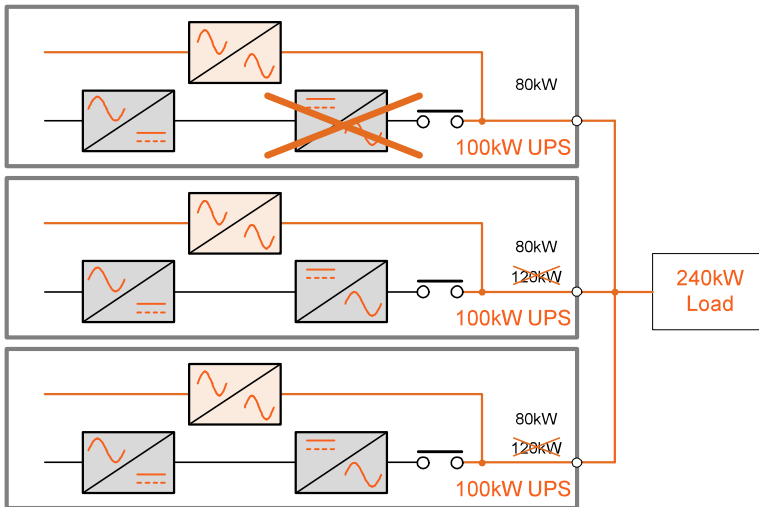

Figure 7.2: Capacity System – on bypass due to faulty module

If the static switch in the faulty module fails to operate, the static switches in the remaining (healthy) modules could be overloaded and their protective devices will operate, causing a loss of load power (Figure 7.3).

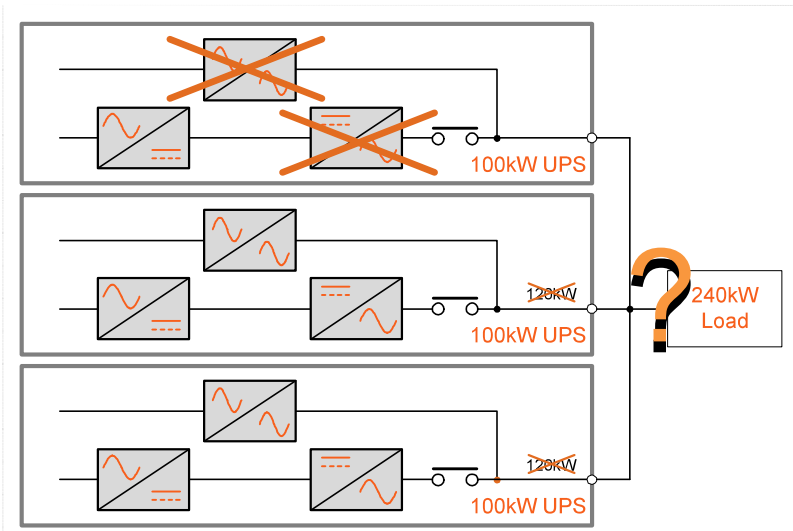

Figure 7.3: Capacity System – dropped load due to bypass failure

Redundant Systems

A parallel redundant system contains **at least one** UPS module over and above that required by the ‘capacity’ system. Using the previous example, a redundant system for a 240kW load using 100kW UPS modules requires four modules with each module supplying 60kW under normal circumstances.

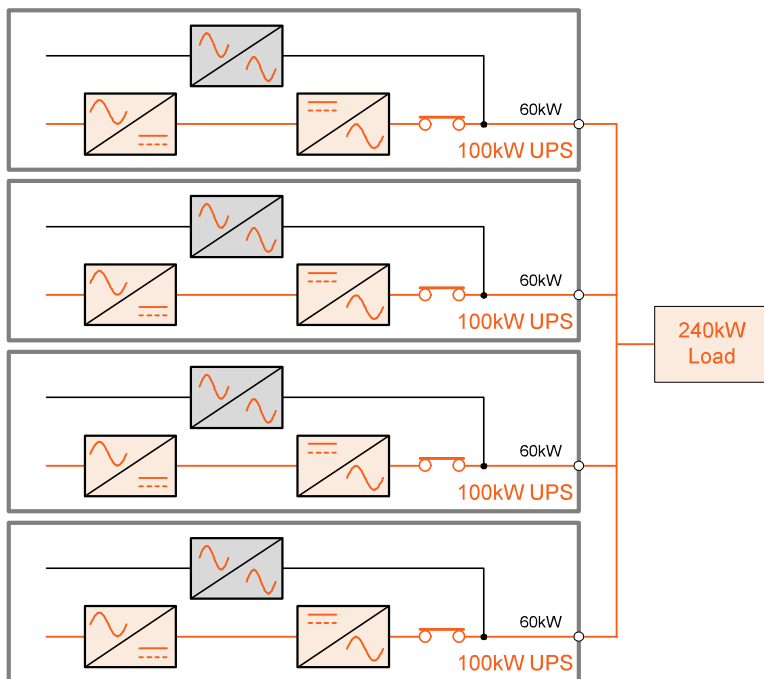

Figure 7.4: Parallel Redundant System

In this example, if one module develops a fault it trips off line and the remaining healthy modules continue to supply the load with each unit providing 80kW, as shown in Figure 7.5. The system will automatically transfer the load to bypass following the failure of a second module in the same manner as that described earlier concerning the ‘capacity’ system.

If extra security is required, the number of redundant modules can be increased to two (or more). A ‘redundant’ configuration is sometimes referred to as an ‘N+1’ (or ‘N+2’) system – where ‘N’ signifies the minimum number of modules needed to supply the load and ‘1’ or ‘2’ signifies the number of redundant modules (i.e. the coefficient of redundancy) in the system.

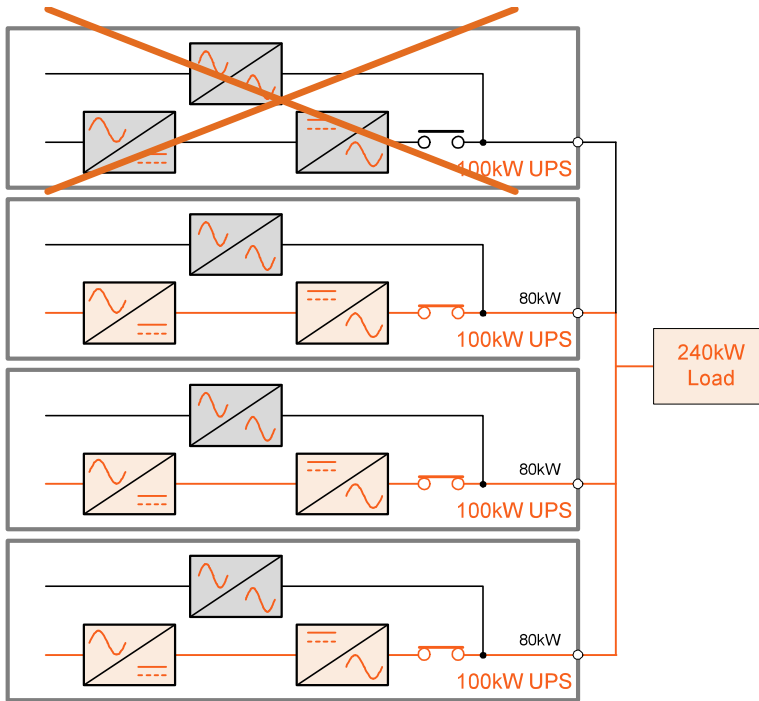
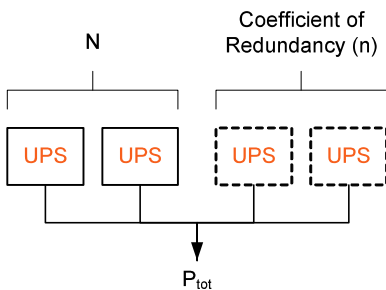

Figure 7.5: Redundant System with Failed Module

Definition of a Parallel Redundant UPS System



Total number of UPS modules = $N + n$

$$N = \frac{P_{tot}}{UPS_{min}}$$

Where:

UPS_{min} = Max. power rating of each UPS module

P_{tot} = Total load power requirement

N = Min. number of UPS modules needed to supply P_{tot}

n = Min. coefficient of redundancy

Dynamic redundancy control

A UPS module that is intended for use in a modern-day modular system is designed to operate in a parallel redundant environment in which it is normally expected to run at somewhat less than 100% capacity. For this reason, one of the design aims is to produce a module with a high efficiency characteristic across its entire mid-to-high capacity range and not just at its maximum output. For example, a typical transformerless UPS module might have an efficiency of around 96% for loads from 90% down to 35%, then fall to something in the region of 88% at 7.5% load – see the ‘Normal efficiency’ curve shown in Figure 7.6, below.

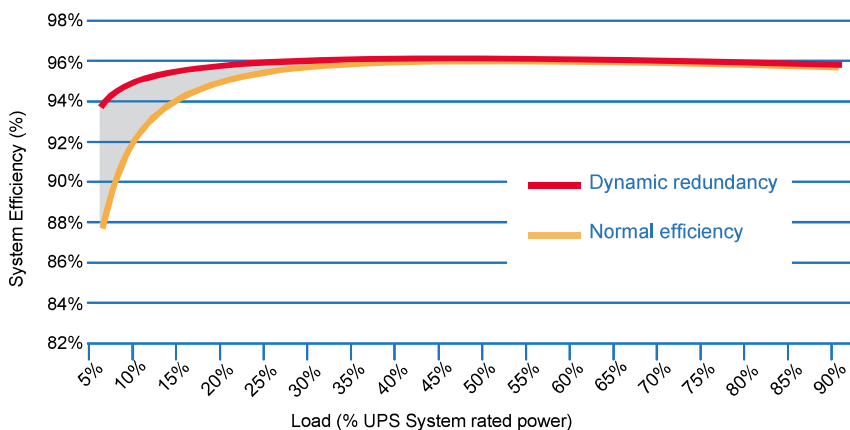

Figure 7.6: Dynamic redundancy – efficiency graph

When several such UPS modules are installed in a redundant module system, the ability to operate with a consistent efficiency over a wide capacity range makes the system very flexible.

For example, consider a system comprising ten, 100kW modules with the efficiency characteristics just described:

- If the system is specified as an N+1 system it can supply a 900kW load, with each module loaded to 90% (90kW) and a system efficiency of 96%.
- If the load falls to 800kW, the system effectively operates as an N+2 system with each module loaded to 80% (80kW), but still with a system efficiency of 96%.

- If the load falls further to 400kW, the system becomes an N+6 system, with each module loaded to 40% (40kW), but maintaining a system efficiency of 96%.
- However, if the load reduces down to as low 100kW, the system effectively operates as an N+9 system. Each module now operates at just 10% capacity (10kW) but the efficiency falls off to around 92%.

The reduced efficiency at low load represents wasted energy and expense.

A recent design innovation, described here as '*Dynamic redundancy control*,' can compensate for the reduced low load efficiency by dynamically controlling the number of on-line UPS modules in response to changes in load demand.

That is, the dynamic redundancy control system:

- Monitors the prevailing load.
- Calculates the number of UPS modules required to supply the load, including a preset number of redundant module(s).
- Switches any surplus UPS modules to standby mode.
The inverter is turned off in the modules operating on 'standby' to reduce the module(s) power consumption but can be brought back on-line within 40~50ms if the system load increases.

For example, consider the ten module system described above, feeding a 100kW load but with dynamic redundancy control applied. If the dynamic redundancy control is programmed to operate as an N+1 system it will switch eight modules to standby, leaving the two remaining modules loaded to 50%. This results in the system efficiency increasing from the 92% given in the previous example back to 96%. The effect of this control mechanism can be seen to improve the system efficiency by up to 5% at very light loads, as shown in Figure 7.6.

In a well designed system the active (on-line) UPS modules are rotated automatically on a scheduled basis (e.g. weekly) to balance their use over time. The in-coming modules should be brought on-line before the outgoing modules are switched to standby to ensure the module rotation is transparent at the system output.

Dynamic redundancy control is not recommended for all types of installation, especially those with frequent or rapidly changing load demands.

N+N Redundant System

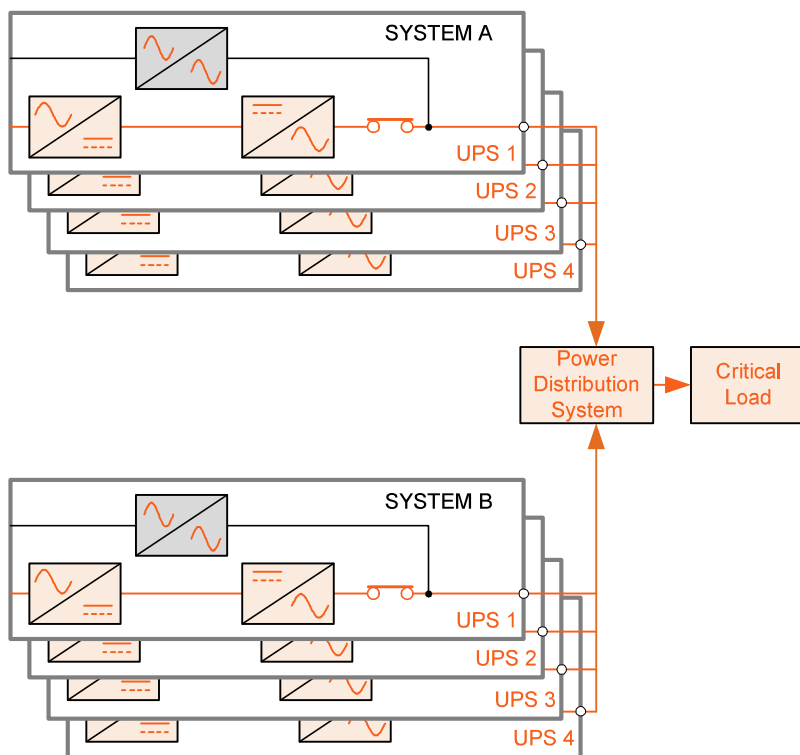

Figure 7.7: 'N+N' Redundant System

An 'N+N' redundant UPS system effectively comprises two fully functional, but independent, stand-alone modules or complete 'N+n' systems, connected to a common load. In a true 'N+N' system the entire load can be supplied from either UPS system, so this must be considered to be the ultimate redundancy design.

Figure 7.7 shows two 4-module parallel redundant systems, System A and System B, configured for 'N+N' operation. The output from both UPS systems is connected to the critical load via a power distribution system which determines how the two UPS power sources are consumed by the load equipment. The most commonly used distribution implementations are described on the following page.

Dual Supplied Servers

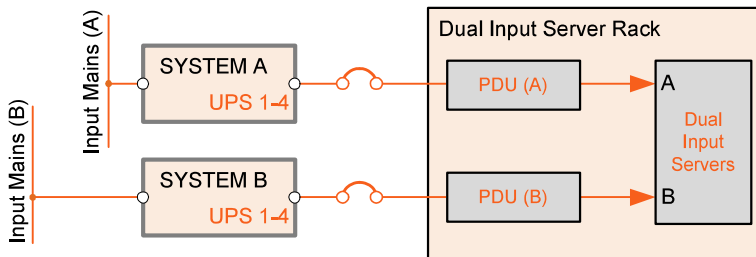

Figure 7.8: N+N System for Dual Supplied Servers

Many of today's rack-mounted servers, routers, data storage and other critical load devices, contain dual internal power supplies units (PSUs) that can be fed from two independent sources. These dual-powered load devices can operate fully from either one of their two internal PSUs which in itself introduces a degree of redundancy additional to that offered by the UPS system.

Figure 7.8 illustrates a dual input server rack powered by an 'N+N' configured UPS system. The diagram shows a dual input server powered by two power distribution units (PDUs) with each PDU being supplied by one of the two UPS systems. In practice, the two PDUs will distribute power to all the servers and associated equipment installed in the rack, not just the single item shown.

This clearly illustrates that all the load equipment will receive processed and backed-up power provided that at least one of the two UPS systems is operating – although under normal circumstances both UPS systems are on-line.

The overall system reliability is further enhanced by using segregated input mains power sources for the two UPS systems.

Switched Supplies

In the 'N+N' design shown in Figure 7.9, the outputs from the two UPS systems are connected to the critical load via a static transfer switch (STS). The STS contains a pair of inverse-parallel connected SCRs in each UPS system output line and operates in a similar manner to the static switch described in Chapter 5, page 78.

Depending on the size and type of the connected load, the STS can be either a large unit installed in a stand-alone cabinet, or contained in a standard rack-

mountable case and fitted in a rack enclosure where it controls the power to the remaining rack-installed items.

Under normal circumstances both UPS systems are turned on but only one is connected to the load via the STS – the off-line UPS system is fully operational but acting as a standby. If the on-line UPS system fails, the STS will transfer the load to the standby UPS system very quickly without disrupting the load supply. The STS usually includes a manual transfer facility to allow the on-line and off-line systems to be swapped periodically to balance the system usage or undertake system maintenance.

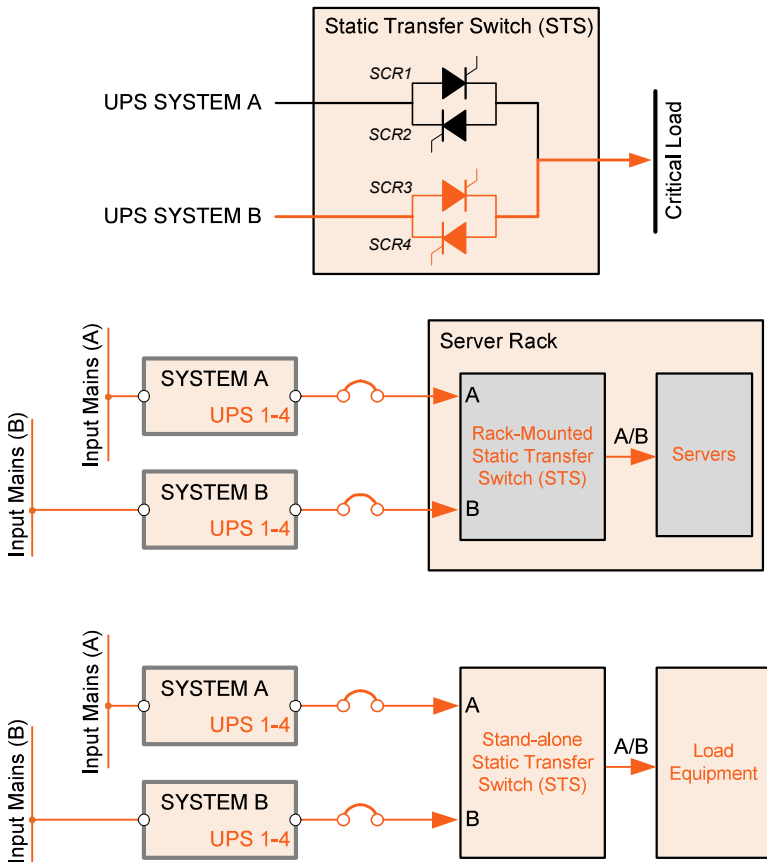

Figure 7.9: N+N System Using a Static Transfer Switch

Centralised and Decentralised Systems

Note: In this discussion the term 'Decentralised System' is used to describe the UPS architecture, in that each UPS module incorporates its own static bypass switch. This should not be confused with the interpretation of the term 'Decentralised System' often used in data centres to describe the situation where individual power systems are provided alongside the various load equipment – e.g. as part of an IT equipment rack.

Introduction

Parallel UPS systems comprise a number of UPS modules that either share common components (i.e. they *cannot* operate as a “stand alone” UPS), or are completely independent (i.e. the modules *can* operate as a “stand-alone” UPS).

Parallel UPS systems whose UPS modules operate as a system by sharing common components are known as “centralised” systems and described as having a Centralised Parallel Architecture (CPA). The major benefit of CPA systems is one of reduced cost, as expensive components, such as those used in the module control circuitry and static switches, can be used simultaneously by all of the modules in the system, thereby negating the need for each module to have its own control circuitry and static switch. The major drawback of CPA systems is that the “centralised” nature of the control and power switching components introduces a number of “single points of failure” into the system which adversely affects the system's availability.

Parallel UPS systems whose UPS modules share no common components are known as “decentralised” systems and are described as having a Decentralised Parallel Architecture (DPA). The major benefit of DPA systems is that there are effectively no single points of failure in the system so the system availability is inherently greater. Conversely, the major drawback of DPA systems is the initial purchase cost, as each module in the UPS system has its own, independent, control circuitry and static switch etc.

Centralised Systems

This type of parallel system configuration typically has all the UPS modules feeding the critical load via a single, centralised static switch (CSS).

With single-phase and small three-phase UPS systems, the CSS is sometimes built into the cabinet housing the various UPS modules; but for large three-phase systems the CSS is almost always housed in a separate cabinet.

The remainder of this chapter assumes that the CSS is housed in a separate cabinet as illustrated in Figure 7.10, which shows three UPS modules working in parallel with a centralised static switch (CSS). The total system capacity depends upon the rating of the individual UPS modules and the number of modules used. Additional modules can be added to the system to cater for future load expansion provided that the combined module capacity does not exceed that of the CSS.

In each of the UPS modules, the inverter is shown connected to the critical load via a module output contactor. These contactors operate in unison in a parallel system so that when the load is transferred to the UPS *all* the module output contactors close simultaneously, and open simultaneously when the load is transferred to the bypass supply.

Also, if a UPS module operating in a redundant system develops a fault the UPS output contactor automatically opens to isolate the faulty module and so enable the remaining modules to stay on line. In most parallel systems a mechanical isolator switch is also fitted immediately ahead of the module output to allow a module to be isolated manually if required for service or repair

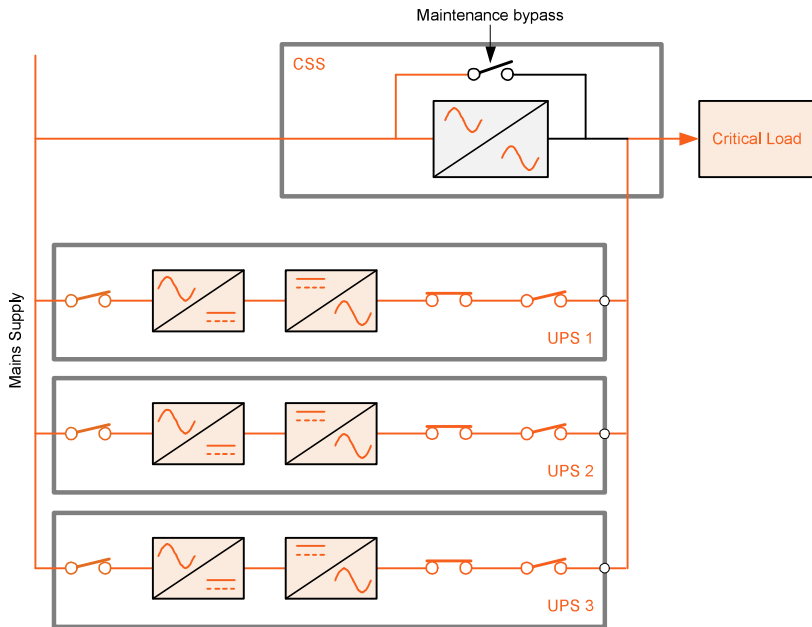

Figure 7.10: Three Module Centralised UPS System

Central Static Switch (CSS)

The CSS cabinet shown in Figure 7.11 includes a ‘maintenance bypass’ facility, and so provides three possible power paths to the critical load:

- the UPS output supply from the inverters
- bypass (raw) mains via the static bypass
- bypass (raw) mains via the maintenance bypass

Note: the maintenance bypass facility is optional.

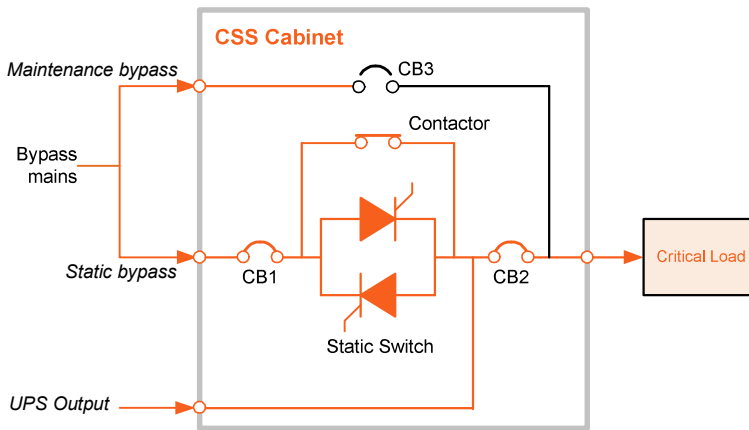

Figure 7.11: Typical CSS Configuration

UPS Output Supply

During normal operation all the UPS modules are on line – i.e. all the module output circuit breakers are closed – and the UPS system feeds the critical load through the CSS output circuit breaker (CB2).

The modules are synchronised to one another and also to the standby mains supply (if present) and share equally the critical load current.

Static Bypass Supply

This supplies the load when the UPS modules are unable to do so: for example due to overload, module failure, loss of redundancy etc.

The static bypass line is fed from the raw bypass mains supply and connected to the critical load via the CSS input circuit breaker (CB1), the static switch SCRs and the CSS output circuit breaker (CB2). Both CB1 and CB2 are closed during normal (non-maintenance) operation so this path is effectively controlled by the operation of the static switch SCRs.

Depending upon the power rating of the CSS, the static switch SCRs may be paralleled by a contactor which closes when the devices are turned on. This reduces the time for which the SCRs are required to pass the load current, so relatively low powered (and therefore lower cost) devices can be used.

Maintenance Bypass Supply

The (optional) maintenance bypass is manually selectable and connects the critical load to the unprotected bypass mains supply. This is normally used only as a temporary measure to power the load when it is necessary to shut down the complete UPS system – for example when undertaking system troubleshooting.

In Figure 7.11 the maintenance bypass is connected via CB3 and to prevent back-feeding the UPS inverters with bypass mains power when CB3 is closed, an electro-mechanical interlock prevents the maintenance bypass circuit breaker from being operated while the UPS modules are on line – i.e. while the module output contactors are closed.

Static Switch Operation

The load transfer mechanism in a centralised UPS system with a CSS is the same as that described for a stand-alone UPS module in Chapter 5, page 78.

To obtain a clean load transfer between the UPS modules and static bypass, the UPS output must be synchronised to the bypass mains supply.

When a load transfer is requested under synchronised conditions the module output circuit breakers are opened at the same time as the static switch is turned on in the CSS cabinet. Conversely, if the system is not synchronised at the point of transfer then the module output circuit breakers are opened slightly before the static switch is turned on, resulting in an unavoidable brief power break and possible loss of the critical load.

Critical load loss might also occur if the standby mains supply is unavailable during an overload.

Decentralised Systems

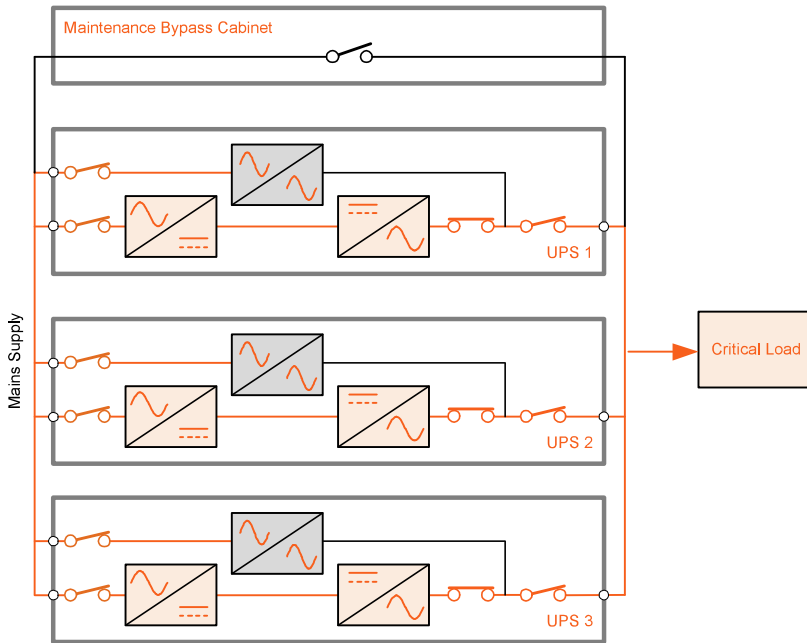

Figure 7.12: Three Module Decentralised UPS System

In this type of parallel system all the UPS modules feed the critical load directly. A block diagram of a typical decentralised parallel system containing three UPS modules is shown in Figure 7.12.

The system capacity depends upon the UPS module rating and the number of modules used, and additional modules can be added to the system to cater for future load expansion.

UPS modules in a decentralised parallel system are practically identical to a stand alone UPS and some manufacturers design their UPS to be used in either configuration without modification, as previously mentioned.

Decentralised parallel UPS systems always have one 'Master' module with the other modules in the system being 'Slaves'. If at any time the Master becomes faulty, or is isolated for maintenance etc., the next UPS in the system (former Slave) will immediately take over the Master function and the former Master will switch off.

Decentralised Static Switch

In a decentralised system every UPS module contains its own static bypass circuit, usually in the form of an SCR-controlled static switch similar to that fitted in the CSS cabinet in the centralised UPS system just described.

However, unlike the case of the centralised system, which employed a single static switch rated for the full system capacity, each static switch in a decentralised system is rated for the individual module's full load capacity only.

As with the centralised system there are still three possible power paths to the critical load:

- the UPS output supply from the inverters
- bypass (raw) mains via the static bypass
- bypass (raw) mains via the maintenance bypass

Note: the maintenance bypass facility is optional.

During normal operation all the UPS output contactors are closed and the UPS modules are on line with the UPS inverters feeding the load. All the inverters are synchronised to each other and to the standby mains supply (if present) and share the load equally.

If a UPS module develops a fault it automatically isolates itself from the critical load by opening its output contactor. The critical load will continue to be supplied from the remaining healthy modules if the load does not exceed the available system capacity.

If the critical load is too great for the remaining modules to handle, all of the modules (including the module with a fault) will transfer the critical load to the bypass mains via their internal static switches.

If the system is synchronised, the static switch SCRs are turned on at the same time as the module output contactors are open and the transfer is break-free. If the system is not synchronised the UPS modules will not allow any transfer to take place and will attempt to supply the overload for as long as possible before their internal protection operates.

Note that for both centralised and decentralised systems the bypass mains and maintenance bypass mains can be connected to a dedicated bypass power supply or linked to the UPS (rectifier) input mains.

Conclusion

Originally, centralised parallel systems were the only type of parallel systems available due to the complexity of data and signal processing required to effectively control a decentralised system.

A decentralised system offers easier system expansion due to the fact that additional modules can usually be added to the system without having to power down the load or make mechanical upgrades to the existing system. Depending on the rating of the components in a centralised UPS system it may be necessary to upgrade the CSS static switch and circuit breakers when additional modules are added to an existing system.

The need for a separate CSS cabinet makes a typical centralised parallel system physically larger, more complicated to install and more expensive than its decentralised counterpart. When this is coupled with the fact that the static switch and system control components of the CSS provide single points of failure to the critical load it is clear to see why decentralised parallel systems are now the most popular choice.

One argument sometimes advanced in support of the centralised parallel system is the fault clearing capacity of the Central Static Switch. However, modern decentralised systems incorporate internal static bypass switches capable of matching the fault clearing capacity of the Central Static Switch.

Modular UPS Systems

It was the development of transformerless three-phase UPS technology that enabled the development of rack mounted, modular three-phase UPS systems. Transformer based three-phase UPS modules would be far too large and heavy to be considered viable in a truly modular system. For example, excluding batteries, a typical transformer based 50kW three-phase UPS weighs 400kg whereas the latest modular three-phase UPS weighs less than 50kg.

It is widely recognised that the introduction of transformerless three-phase UPS in the mid 1990s revolutionised three-phase UPS design. This is borne out by the fact that all major UPS manufacturers now have three-phase transformerless UPS within their product portfolios. It is also widely recognised that modular three-phase UPS technology is revolutionising three-phase UPS system design. This is because only modular UPS systems can simultaneously offer the benefits of very high availability, easy scalability and total system flexibility.

Hot Swappability

A modular UPS system that needs to be either switched off or manually bypassed to allow the addition or removal of a module (for example, in the event of a module failure or system upgrade) is undesirable because the overriding objective of any UPS system is to NEVER expose the critical load to unprotected power. With this in mind, some manufacturers have designed their UPS modules to be “hot swappable”.

The single most important benefit of hot swappable UPS modules is the affect that they have on system mean time to repair (MTTR) and the impact that this has on system availability.

A module is hot swappable if:

1. It can be inserted or removed from the host system without:
 - a. transferring the critical load to the raw AC mains supply
 - b. removing power from the critical load
2. It can be safely electrically disconnected from its host system using electrically safe connectors.
3. It can be isolated from the rest of the host system without the risk of human error that may cause damage to the module, the host system or the critical load.

Modular UPS systems that contain modules that are not hot swappable as defined above are often described as being “warm swappable”.

Availability

Earlier in this chapter it was established that UPS system availability was significantly increased if individual UPS modules were connected to each other in a decentralised, parallel redundant configuration. When the benefit of significantly reduced MTTR provided by hot swappable modules is added to such a configuration the result is maximised availability.

The subject of system availability is covered in greater depth in Chapter 11, on page 215. To avoid excessive duplication of information it is sufficient in this chapter to simply state that hot swappable modular UPS systems increase overall system availability by a factor of 10 compared to free standing (non-modular) UPS systems that are not hot swappable.

Scalability and Flexibility

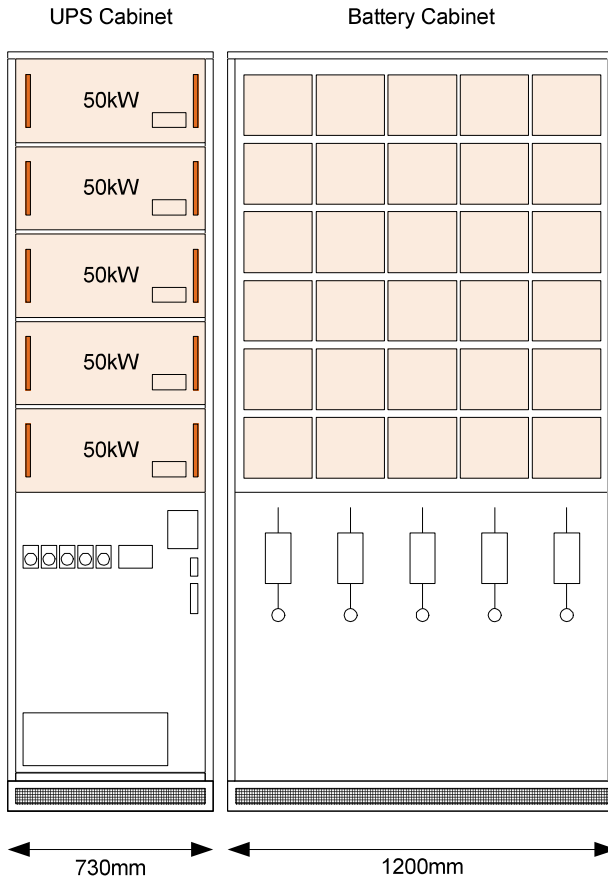

Figure 7.13: Rack mounted, Transformerless UPS Configuration

Figure 7.13 shows three decentralised, rack-mounted UPS installations designed around 50kW plug-in UPS modules – all of which can operate in a redundant or capacity mode according to the applied load demand. Two and three UPS modules, together with internal batteries of different capacities, are shown in the left and centre cabinets. The right hand illustration shows a fully populated cabinet housing ten UPS modules, and requiring an external battery (not shown). Rack-mounting the UPS modules in this way significantly reduces the required floorspace.

Examples illustrating the flexibility of this type of system are given below.

Example 1



200kW (N+1) - 10 mins

Figure 7.14: Vertical Scalability

Figure 7.14 shows 5 x 50kW UPS modules used to support a 200kW load with N+1 redundancy. Alternatively, the user could have employed 4 x 50kW UPS modules to support a 200kW load, and taken advantage of the vertical scalability opportunities of the system to upgrade to 250kW cost-effectively, and with no disruption to the critical load or footprint penalty, by adding a further 50kW module at a later date.

Figure 7.15 illustrates a modular UPS system able to support a 300kW load with N+1 redundancy, with the ability to expand to 450kW N+1 or 500kW capacity in cost-effective increments and with no extra footprint requirement. Such a system may be expanded indefinitely by adding relatively small-footprint UPS and battery cabinets.

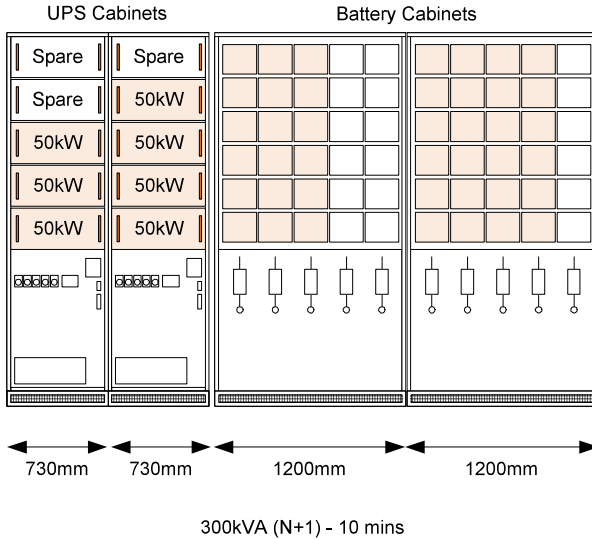

Figure 7.15: Horizontal Scalability

Figure 7.16 shows a sophisticated UPS installation utilising rack mounted UPS modules. On the first floor, a three module UPS is configured with 3 x 50kW UPS modules, with redundancy, supporting two server/comms racks. On the ground floor, 4 x 50kW modules, with redundancy, support three server/comms racks and has two spare slots to allow for expansion.

The user decides to move one of the server/comms racks from the first floor to the ground floor, overloading the existing ground floor power support system (Figure 7.17). It is a simple matter to move one UPS module and respective battery to the ground floor to restore the balance (Figure 7.18). There are spare slots within the ground and first floor UPS cabinets to allow for future expansion of the protected system. Further capacity can be obtained by simply introducing additional UPS modules as and when required. The important point is that all of these changes can be made with minimum effort, low incremental cost, no disruption to the critical load and without using any more floor space.

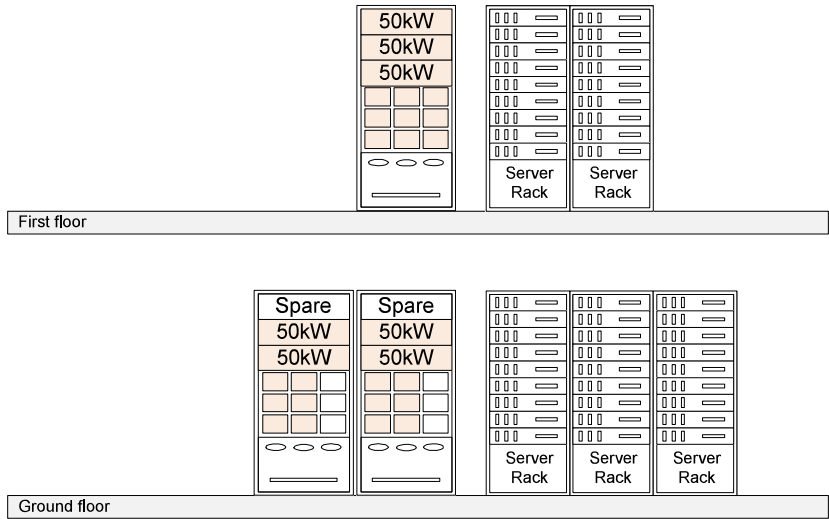

Figure 7.16: A Flexible and Upgradeable UPS System (a)

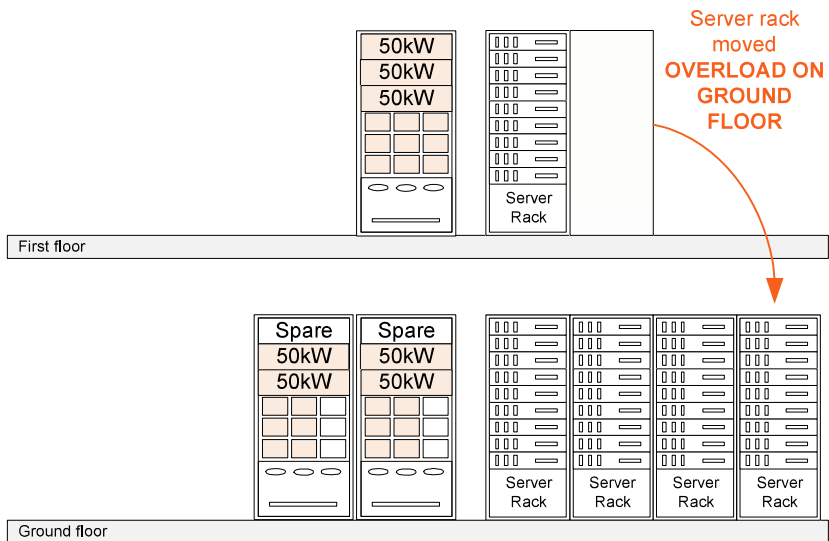

Figure 7.17: A Flexible and Upgradeable UPS System (b)

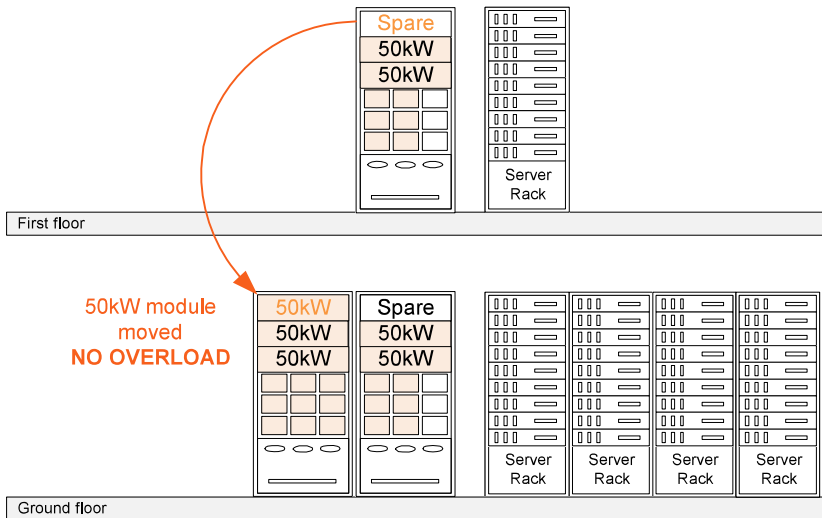

Figure 7.18: A Flexible and Upgradeable UPS System (c)

As an added bonus, if one UPS module should develop a fault, the user can easily arrange for a module to be moved from one floor to the other as an emergency measure pending service, albeit by temporarily sacrificing redundancy.

Serviceability is substantially improved by this modular technology because UPS modules can be swapped out for service and access is only required to the front of the UPS cabinet. As a result MTTR is significantly reduced.

Example 2

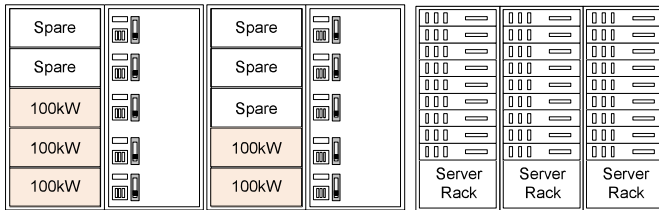

Figure 7.19: Expandable 1 MW Modular System

Figures 7.19 and 7.20 illustrate the same flexibility and upgradeable facility using 100kW granular steps rather than 50kW.

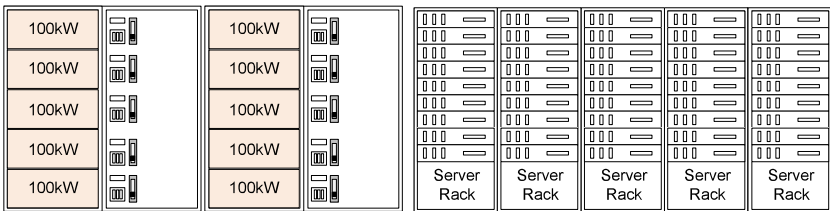

Figure 7.20: Fully Populated 1 MW System

Managing a Parallel System

In the past, parallel systems were managed in a less ideal manner than is possible today using the latest technology. For example, in some older systems the module redundancy was often based on ‘module availability’ rather than the prevailing load itself – i.e. once the number of out of service modules exceeded the designed number of redundant modules the load transferred to bypass irrespective of the load demand and available remaining module capacity.

Modern systems can treat the matter of redundancy more intelligently and effectively.

For example, reconsider the four module (one redundant) system shown in Figure 7.5, on page 100. This shows the situation with one module shut down and the remaining healthy modules sharing the 240kW load equally between them at around 80kW each. If a second module were to fail, the remaining two modules clearly could not support the load as each would exceed its 100kW rating. However, if the load were only 160kW at the time of failure of the second module there is no reason why the remaining two modules could not continue operating and maintain the load on their combined inverters operating at 80kW each (Figure 7.21).

These examples illustrate that the effects of future load requirements should be taken into account when planning a parallel system, and the choice of UPS modules must take into consideration the ease of system expansion if and when necessary.

Traditionally, parallel systems were configured as either ‘capacity’ systems or ‘redundancy’ systems. If a single module failed in a capacity system the critical load would be transferred to bypass irrespective of the critical load demand and the ability of the available module(s) to handle it. Similarly, if the critical load exceeded the available ‘non-redundant’ power, it would be transferred to bypass irrespective of the amount of ‘redundant’ power available.

The example shown in Figure 7.4, on page 99, would be considered a ‘capacity’ system if the load were between 300kW and 400kW, an ‘N+1’ system if the load were between 200kW and 300kW, an ‘N+2’ system if the load were between 100kW and 200kW and an ‘N+3’ system if the load were less than 100kW.

A modern parallel system will automatically adjust its ‘N+n’ status to accommodate the prevailing load.

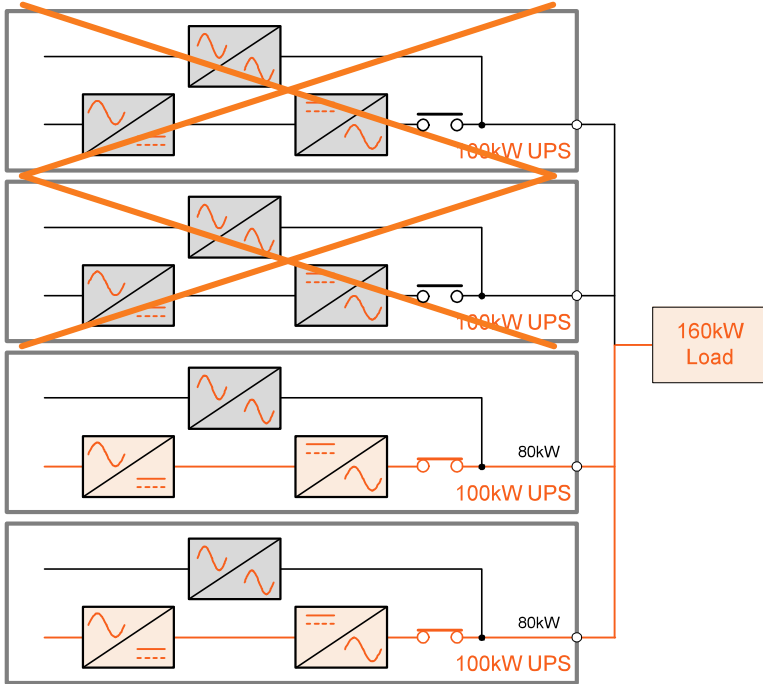

Figure 7.21: Redundant System With Two Failed Modules

Examples of Decentralised UPS Systems

System Requirements

In the following examples the UPS system specification required a 600kW parallel redundant UPS with an upgrade path to at least 800kW parallel redundant to accommodate potential future growth.

Example 1 - Using Free-Standing UPS Modules

The system proposed comprises 4 off 200kW UPS modules configured as a 3+1 (i.e. 600kW parallel redundant) system, with a fully integrated switchgear panel providing all of the required UPS input and output switchgear and associated electrical and mechanical interlocks plus a spare way to enable the addition of a fifth module at a later date.

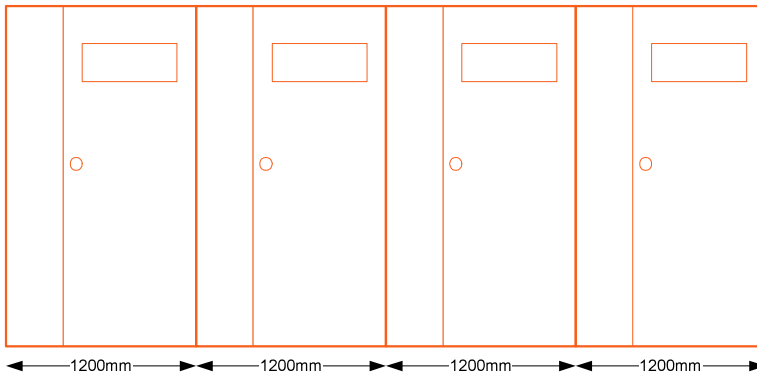

Figure 7.22: UPS System Initial Layout (4 off 200kW UPS)

System and Switchgear Panel Description

Figure 7.23 is a schematic diagram of a 5 way 800kW ‘N+1’ UPS switchgear panel in which 4 off 200kW UPS modules are configured as a ‘3+1’ system to provide 600kW parallel redundancy. A spare way is designed into the panel for the addition of a further 200kW UPS module to permit future system upgrade to 800kW ‘N+1’.

With reference to Figure 7.23 it should be noted that each UPS module has its own input protection which is sized to ensure adequate discrimination between

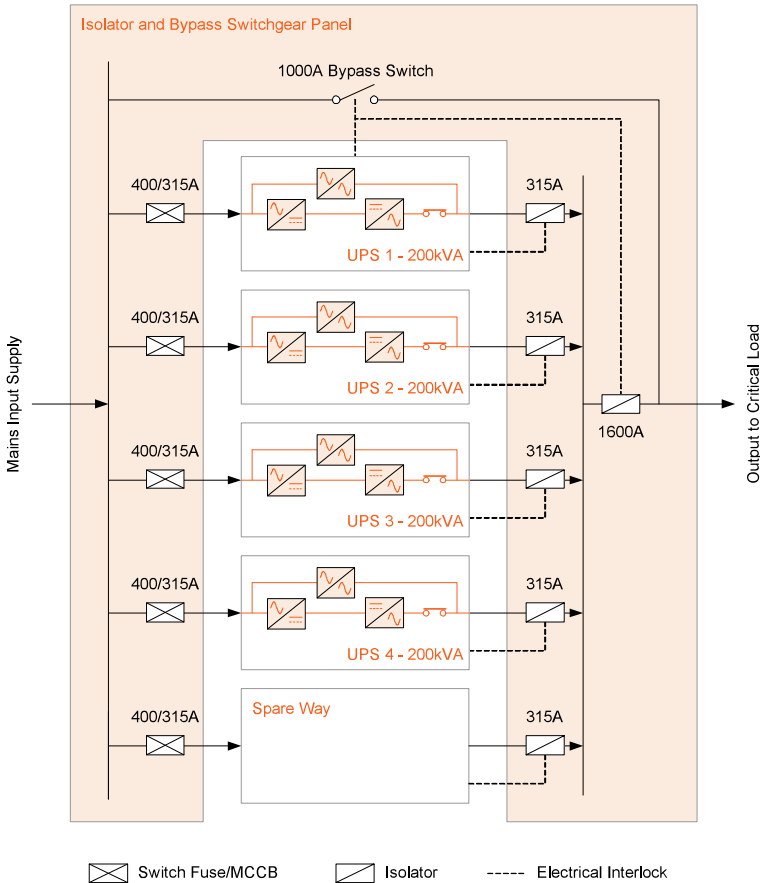

Figure 7.23: UPS Switchgear Panel Schematic

the main panel input fuses and the UPS input. The protection also acts as an input isolator when the respective UPS module requires maintenance etc.

It should also be noted that each UPS module has an output isolator that is electrically interlocked to the UPS system. In any parallel system it is necessary to electrically interlock the output isolator to its associated UPS because whenever the output isolator is open the current sharing circuitry within all of the UPS modules that form the parallel system need to be aware that one of the UPS modules is not required to supply current.

The 5 off UPS output isolators all feed the parallel bus and connected between the parallel bus and the load is the main UPS output isolator. This isolator is required to facilitate full system testing and/or site electrical testing as, in conjunction with the “wrap around” manual bypass switch, it allows the UPS system to be completely electrically isolated from the load without a break in power to the load. The UPS system output isolator and the “wrap around” manual bypass switch are also electrically interlocked to the UPS system. The manual bypass switch is electrically interlocked to prevent accidental damage to the UPS system caused by unauthorised operation of the “wrap around” manual bypass (if the manual bypass switch is closed whilst the UPS system inverters are running, the inverters will be stopped and the system will automatically transfer to static bypass without any break in the supply to the load in order to prevent inverter damage caused by back feeding). By interconnecting the UPS output isolator and wrap around manual bypass switch interlocks, it is possible to fully functionally test the entire UPS system, complete with all paralleling features, without risk to the load.

Another major benefit of the switchgear panel is that it is possible to individually electrically isolate any UPS module connected to the panel, thereby allowing its physical removal and/or physical introduction to the UPS system whilst the load is running and still fully protected by the UPS system. Using such a switchgear panel therefore increases the system flexibility and eliminates the need for the load to ever be exposed to raw mains.

Example 2 - Using Rack Mounted Modular UPS

The proposed system in Figure 7.24 comprises 7 x 100kW rack mounted UPS modules configured as a 6+1 (i.e. 600kW parallel redundant) system with a fully integrated switchgear panel providing all of the required UPS input and output switchgear and associated electrical and mechanical interlocks. Note that a spare way is not required in the switchgear panel as the addition of a module takes place within the already installed UPS cabinet. This also means that the system can be upgraded without the requirement for additional floorspace.

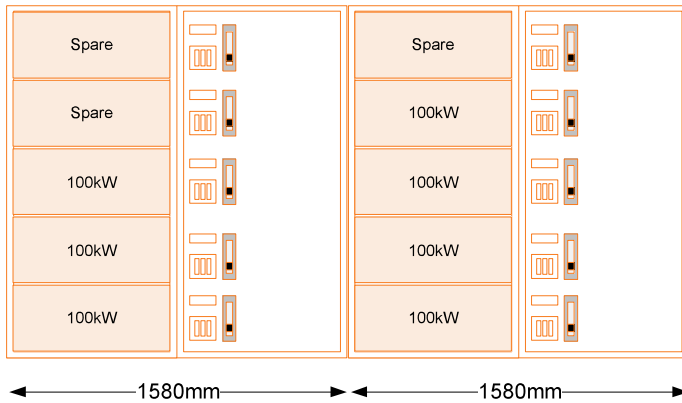

Figure 7.24: UPS System Layout (7 off 100kW rack mounted UPS)

Figure 7.25 is a schematic diagram of a 2 way, 500kW modular UPS switchgear panel in which two UPS system cabinets, each capable of housing up to five 100kW UPS modules.

The UPS system is shown with seven 100kW modules installed to provide 600kW “6+1” parallel redundancy and has a spare way available to facilitate the addition of another three 100kW modules if system upgrade is ever required.

It should be noted that the UPS switchgear panel in Figure 7.25 is considerably simpler than the one shown in Figure 7.23. This is because the majority of input and output switchgear needed by the individual UPS modules is provided within each of the system cabinets housing the UPS modules. For example, the UPS system cabinets themselves contain all of the input protection and input and output isolation required by the UPS modules.

The UPS switchgear panel shown in Figure 7.25 will be physically smaller, less expensive to purchase and easier to electrically install than the switchgear panel shown in Figure 7.23. It should also be noted that no additional electrical installation works will be required to upgrade the system.

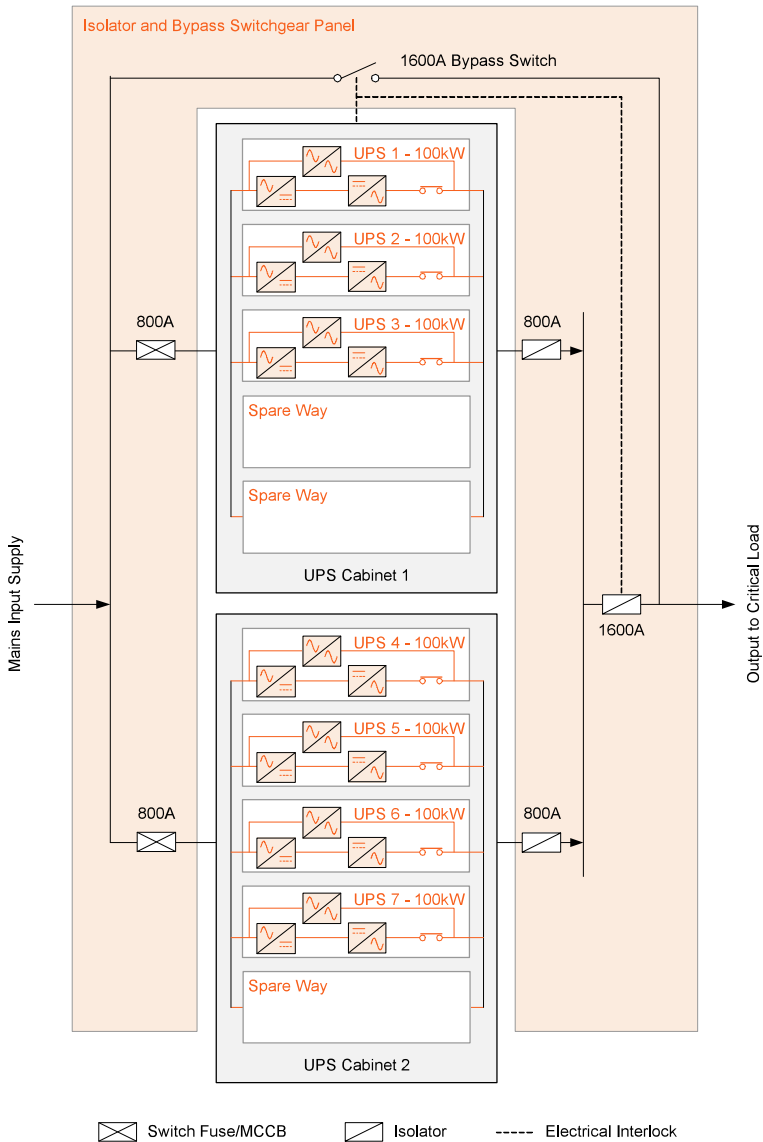

Figure 7.25: UPS Switchgear Schematic

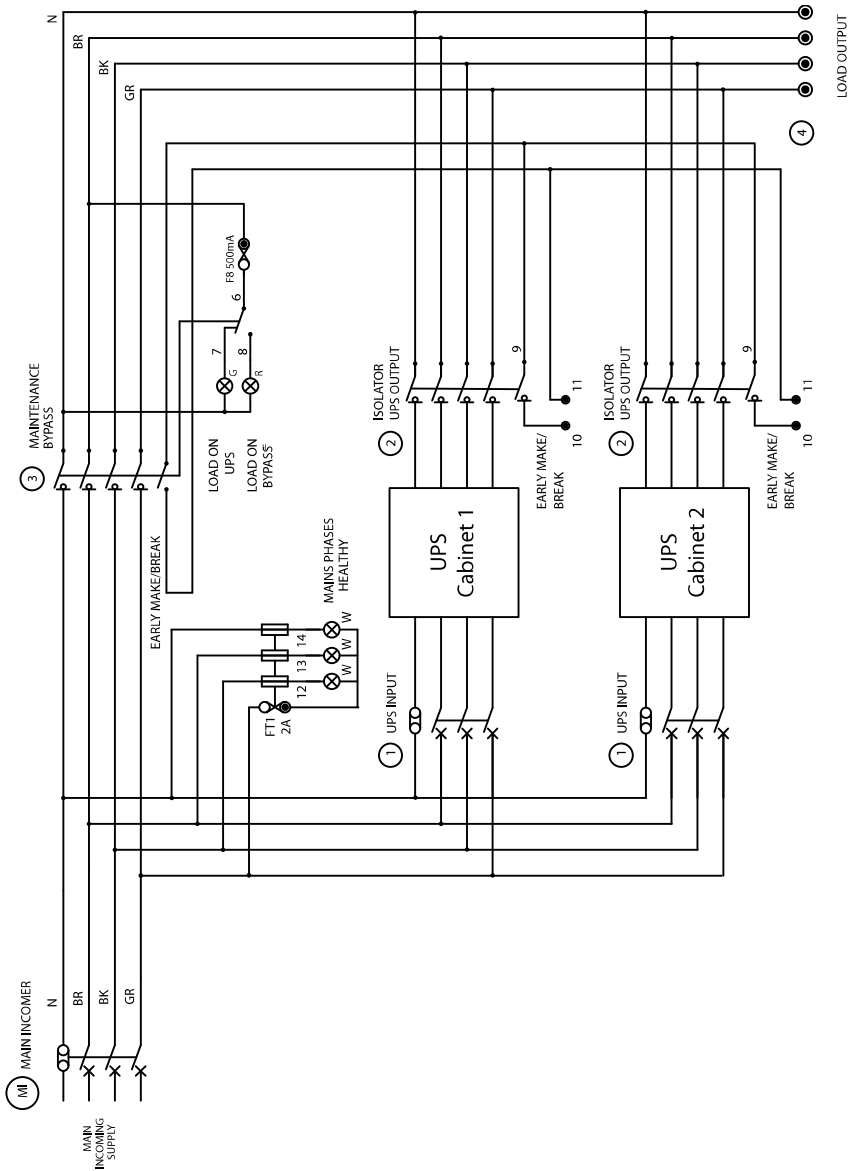

Figure 7.26: A Typical Paralleled UPS System Bypass Panel

Figure 7.26 illustrates a flexible yet tidy way of implementing an expandable parallel UPS system by using a purpose designed panel incorporating input and output switchgear for each UPS cabinet together with a ‘system’ output isolator and a wrap-around bypass switch. Whether paralleling is required for redundancy or scalability, this panel reduces the system design burden, simplifying cabling and shortening cable runs. It also minimises design and implementation complexity, saving time and costs.

Spare ways can be made available on the panel to permit the addition of further UPS modules to provide extra capacity or redundancy at a later date, and additional UPS modules can be connected and commissioned without any need to disrupt the load.

The panel enables electrical and physical isolation of individual UPS modules for service and maintenance without a break to the load.

Electrical interlocks should be included to prevent the UPS modules from being ‘back-fed’ due to incorrect switching.

Parallel UPS System Battery Configuration

The successful design of any parallel UPS system involves the minimisation of the single points of failure.

A potential single point of failure in any UPS system is the battery bank. If a UPS has a single string of batteries and any one battery cell in the string is faulty then the batteries may fail to support the load in the event of a mains power failure. To overcome this problem multiple strings of batteries connected in parallel are used.

Chapter 8 discusses various battery configurations including parallel strings of batteries and the use of transition boxes when paralleling batteries. In summary, parallel strings are used to increase the capacity of a battery system and/or its resilience (by providing battery redundancy) and transition boxes are used to simplify wiring and to individually protect each string in the battery system.

Ideally, each UPS module in a parallel UPS system should have its own set of separately fused paralleled strings of batteries. With large, high powered parallel UPS systems this could be prohibitively expensive and take up too much space within the UPS/computer room. Such cost and space pressures can be partially overcome with careful design of the battery systems by, for example, using more individual strings of lower capacity battery blocks to achieve the required total battery capacity. It is invariably cheaper, however, to have a single string of large batteries rather than multiple strings of smaller batteries.

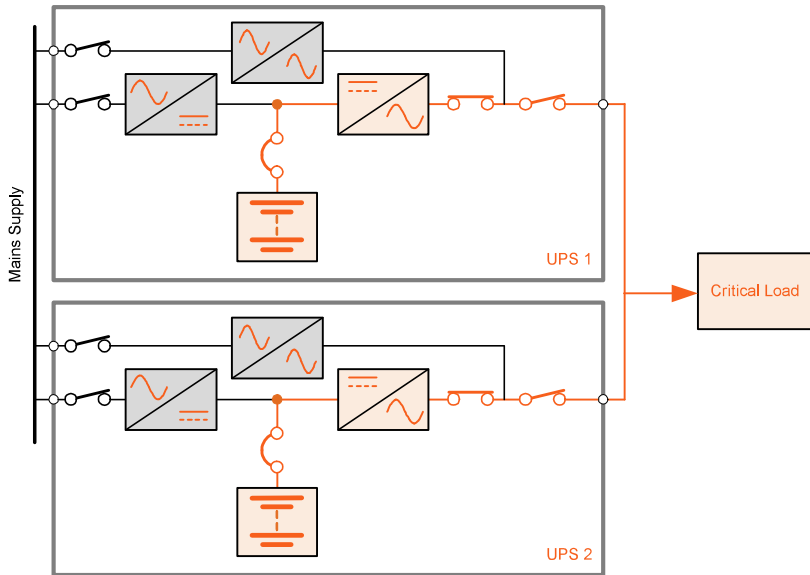

Figure 7.27: Parallel UPS System with One Battery String

Figure 7.27 shows a two-module parallel UPS system where each UPS module has a single string of batteries. In such a configuration, if any one battery cell is open circuit in either of the battery strings only one UPS module will be able to operate in the event of a mains power supply failure. In a capacity parallel system this may result in the overloading of the UPS module with good batteries potentially resulting in a load loss. In a parallel redundant system the battery failure will result in redundancy being lost, however the critical load will be maintained without interruption.

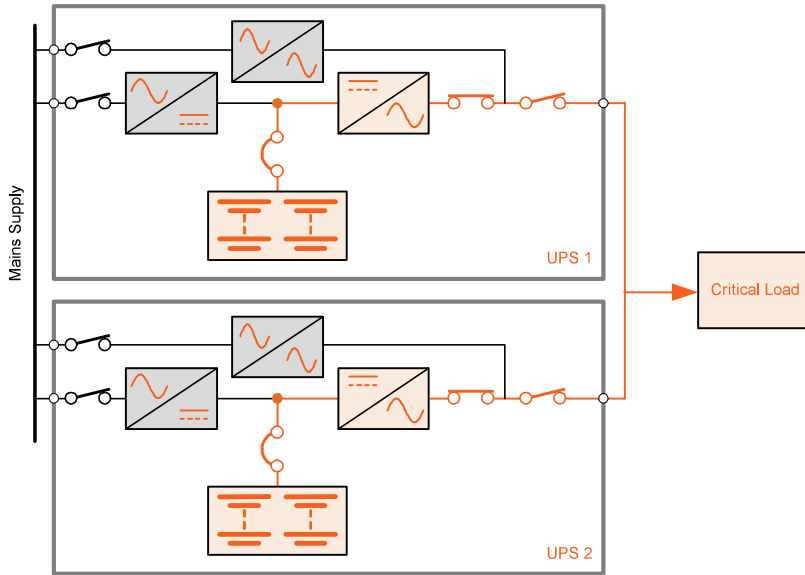

Figure 7.28: Parallel UPS System with Dual Battery Strings

Figure 7.28, shows the same two-module parallel UPS system but this time each UPS module has two strings of batteries connected in parallel. If any one battery cell in such a configuration is open circuit both UPS modules will still be able to operate. As both UPS modules equally share the load, the UPS module with only one good battery string will discharge its good batteries quicker than the other UPS module but with appropriately rated batteries and correctly configured auto-shutdown software the critical load will be protected.

Common Battery Configuration

Both the systems shown in Figure 7.27 and Figure 7.28 have batteries that are configured as “separate batteries” – i.e. each UPS module has its own set of batteries which cannot be accessed by any other UPS module in the system. It is possible to configure the batteries as a “common battery” system where all of the batteries are physically connected to all of the UPS modules in the system.

Common battery configurations utilising multiple strings overcome the problems presented by open circuit cells as discussed in the earlier paragraphs but, unless great care is taken with the common battery's DC distribution system, such a battery configuration can present a single point of failure (e.g. a short circuit on the DC bus of one of the UPS modules may cause all of the battery fuses in the system to fail).

An example of a DC distribution system designed to connect all of the system batteries to all of the UPS modules in the system is shown in Figure 7.29.

Figure 7.29 shows the DC distribution system for a 6 module parallel UPS system with 4 strings of batteries configured as a common battery. For illustrative purposes the UPS DC input protection has been rated at 250A and the battery string protection has been rated at 630A. In a practical application the actual rating of the protection would depend upon the power rating and quantity of UPS modules and batteries.

It can be seen that a short circuit on the DC bus bars within any of the UPS modules will not affect any of the other UPS modules or any of the battery protective devices. It can also be seen that a short circuit within any of the battery strings will not affect any of the other battery protective devices or any of the UPS modules.

The only single point of failure of this system are the DC bus bars themselves but as these are solid copper bars protected and enclosed within a bus bar chamber it is highly unlikely that a short circuit will be presented here. It is still, however, a single point of failure within the overall system and if such a single point of failure is considered unacceptable to the UPS user the batteries must be configured as separate batteries.

Note: The drawing in Figure 7.29 shows a three-wire connection which connects the UPS neutral to the centre of the battery string. This connection is not required by some of the more recent transformerless UPS designs which employ a fully floating battery system.

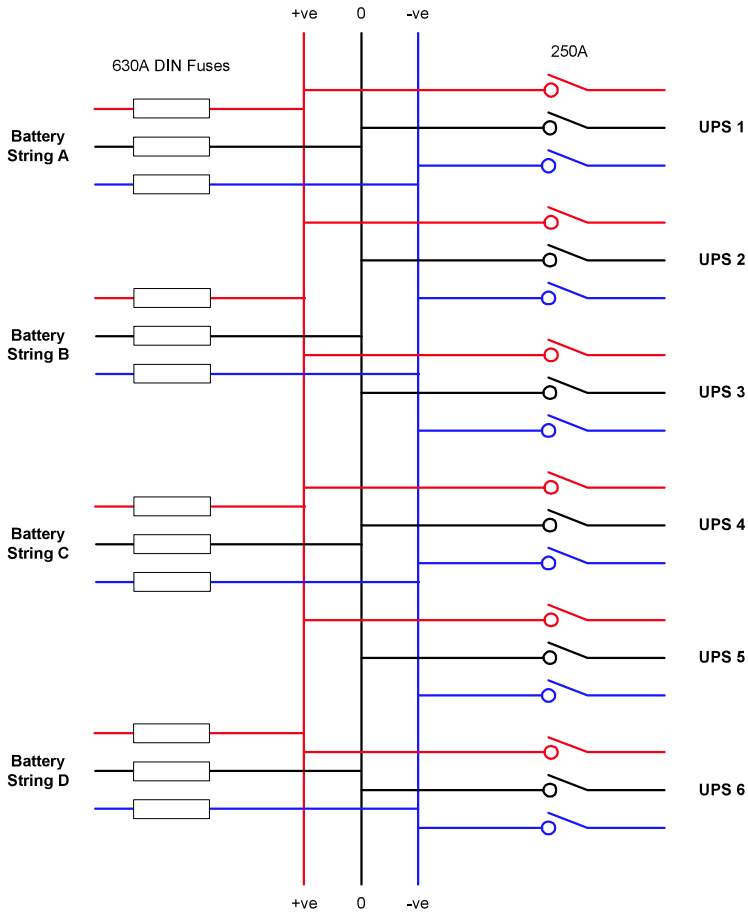

Figure 7.29: DC Distribution System for a Common Battery

Optimum Battery Configuration

The optimum battery configuration for a parallel UPS system will vary depending upon the site facilities (standby generator, available space etc.) and the load requirements. A good UPS supplier will be able to discuss all of the options available to allow the UPS user to make an informed decision on the configuration that best suits their requirement and budget.