

PowerWAVE 8000DPA S2 (10-200 kW)

Technical Specification



POWERWAVE 8000DPA UPS SYSTEM DESCRIPTION

Using a unique modular construction, the PowerWAVE PW8000DPA ST Series 2 model range represents a completely new generation of medium power 3-phase UPS systems that incorporate the latest technological developments in power engineering. High reliability, upgrade ability, low operating costs and excellent electrical performance are just some of the highlights of this innovative UPS solution. The system's advanced double conversion, Voltage and Frequency Independent (VFI) topology fully satisfies the highest availability and environmentally-friendly requirements compliant with the most stringent safety, EMC and other important UPS standards. It is certified to International Standard ISO 9001/EN 29001 and ISO 14001.

PowerWAVE PW8000DPA ST Series 2 model range

The PowerWAVE PW8000DPA ST Series 2 is a truly modular system based on 10kW or 20kW UPS modules contained in a purpose-designed cabinet. Depending on the model, the UPS cabinet can contain up to ten 10kW or 20kW UPS modules connected in parallel to operate as either a redundant (n+1) or capacity system.

Five cabinets are available in the PowerWAVE PW8000DPA ST Series 2 model range, with each one being rated according to the maximum number of 20kW modules that it can house – i.e. ST-40 (40kW), ST-60 (60kW), ST80 (80 kW), ST-120 (120kW) and ST-200 (200kW). The ST-40 and ST-60 cabinets are designed to house the UPS batteries but in the case of ST80, ST-120 and ST-200 systems the batteries are housed externally, usually in a matching battery cabinet positioned adjacent to the UPS cabinet.

System expansion

Thanks to the advanced PowerWAVE PW8000DPA ST Series 2 system design, if a cabinet is not fully populated it is possible to add further UPS modules, as required, to increase the system capacity without having to power-down the system or in any way disrupt the load. For example, if an ST-80 (four-module) system is initially purchased with only two UPS modules fitted, an additional two modules can be installed at a later date. This 'hot-swappable' design also allows individual modules to be exchanged while the equipment is fully operational without having to transfer the load to the bypass supply – depending on the system redundancy and existing load demand. Note that all the UPS modules fitted within a cabinet must be of the same rating – i.e. it is not possible to mix 10kW and 20kW UPS modules in the same cabinet.

Further expansion is made possible by connecting up to four UPS cabinets in parallel to provide a total system output of up to 400kW – see page 6 for details.

This Technical Specification provides detailed information concerning the mechanical, electrical and environmental performance of the PowerWAVE PW8000DPA ST Series 2 intended to support and give answers to tender and end-user requirements.

KEY FEATURES	
Best-in-class efficiency	95.5% efficiency across a wide load range 98% in ECO (Economy) mode
Compact size, small foot print	Integral batteries (up to 60kW), saving on expensive floor space
Easy to replace hot-swappable UPS modules	Replace or add modules with no down-time Simple and cost effective upgrading
Flexible battery management	Advanced management of battery charging and preventive failure diagnostics avoids premature deterioration of battery life.
Blade-server-friendly power; full power from 0.9 lead to 0.8 lag	No de-rating required with leading PF loads
Ergonomic design	Easy serviceability
Eco friendly	Energy saving and low carbon footprint
Low power factor at partial and full load (p.f.>0.99 @100% load)	Cost savings during installation and the entire life cycle (TCO)

GENERAL SPECIFICATIONS

Mechanical characteristics – UPS Cabinet

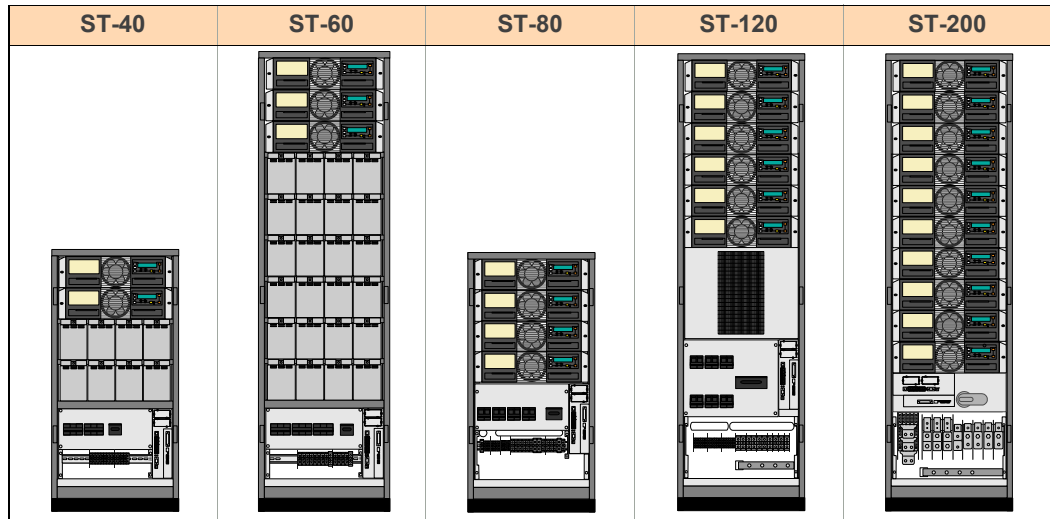

		ST-40	ST-60	ST-80	ST-120	ST-200
Maximum configuration		2 module (10 or 20KW) + 80 x 7Ah batteries	3 modules (10 or 20KW) + 240 x 7Ah batteries	4 modules (10 or 20KW) NO batteries	6 modules (10 or 20KW) NO batteries	10 modules (10 or 20KW) NO batteries
Max. Power	kW	40	60	80	120	200
Dimensions (WxHxD)	mm	550x1135x770	550x1975x770	550x1135x770	550x1975x770	
Weight of empty cabinet	kg	92	173	82	133	174
Weight with modules and no batteries	kg	130 up to 136 (with 2 Modules)	229 up to 238 (with 3 Modules)	157 up to 169 (with 4 Modules)	245 up to 263 (with 6 Modules)	360 up to 389 (with 10 Modules)
Max number parallel cabinets		4	4	4	3	2
Max number of modules per system		8	12	16	18	20
Max system capacity (no redundancy)		160kW	240kW	320kW	360kW	400kW
Colour	RAL 9005					
Operator access	Front					
Cable entry	From the bottom					
Protection class	IP20					

System data

System input characteristics		
Nominal input voltage	V	3x380/220V+N, 3x400V/230V+N, 3x415/240V+N
Input voltage tolerance (ref to 3x400/230V) for Loads in %:	V	(-20 +15%) 3x320/184 V to 3x460/265 V for <100% load (-26% +15%) 3x296/170 V to 3x460/265 V for < 80% load (-35% +15%) 3x260/150 V to 3x460/265 V for < 60% load
Input frequency	Hz	35 – 70
Input power factor		PF=0.99 @ 100% load
Inrush current	A	max. In
System output characteristics		
AC power distribution system		TN-S, TN-C, TN-C-S, TT, 3ph
Output rated voltage	V	3x380/220V or 3x400/230V or 3x415/240V
Output voltage stability	%	Static: < ±1% Dynamic (Step load 0%-100% or 100%-0%) < ±4%
Output voltage distortion	%	With linear load <1.5% With non-linear load (EN62040-3:2001) <3%
Output frequency	Hz	50 Hz or 60 Hz (selectable)
Output frequency tolerance	%	Synchronized with mains < ±2% or < ±4% (selectable for bypass operation) Free running ±0.1%
Efficiency AC-AC up to (at Cosφ 1.0) (tolerance ±0.5% applies to all figures)	%	Load: 100% 75% 50% 25% 95.5% 95.5% 95% 94.5%
Efficiency with linear load at cosφ =0.8 lag		Typically up to 1% higher of above values
Efficiency non-linear load		Typically up to 1% lower of above values
ECO-mode efficiency at 100% load	%	98%
Permissible unbalanced load (All 3 phases regulated independently)	%	100%
Phase angle tolerance (With 100% unbalanced load)	Deg.	<2°.
Crest factor (load supported)		3: 1
Bypass characteristics		
Bypass rated input voltage	V	3x 400V (± 15%) or 196 to 264V ph-N
Output short circuit capability on static bypass	A	10x In during 20ms
Static bypass transfer time	ms	inverter to bypass <1 ms bypass to inverter <5 ms bypass to inverter (ECO mode) <6 ms
Environmental		
Operating temperature	°C	0 – 40
Ambient temperature for batteries (recommended)	°C	20
Storage temperature	°C	-25 to +70 (cabinet) 0 to 40 (batteries)
Battery storage time at ambient temperature		Max. 6 months @ +20°C
Max. altitude (above sea level)	m	1000m (3300ft) without de-rating
De-rating factor for use at altitudes above 1000m sea level according (IEC 62040-3)	Height above sea level (m / ft)	De-Rating Factor for Power
	1500 / 4850	0.95
	2000 / 6600	0.91
	2500 / 8250	0.86
	3000 / 9900	0.82
Relative air-humidity		Max. 95% (non-condensing)
Positioning		Min. 20 cm rear space (required for fan)

UPS Power module data

Mechanical characteristics		10KW UPS Module	20KW UPS Module
Dimensions (WxHxD)	mm	488 x 132 x 540 (3 HU)	
Weight UPS power module	kg	18.6	21.5
Colours		RAL9005	
Input characteristics		10KW UPS Module	20KW UPS Module
Input distortion THDI(sine-wave THDi @ 100% load)	%	<4%	<3%
Max. input power with rated output power and charged battery per module (output Cosφ = 1.0)	kW	10.5	21
Max. input current with rated output power and charged battery per module (output Cosφ = 1.0)	A	15.2	30.4
Max. input power with rated output power and discharged battery per module (output Cosφ = 1.0)	kW	11.5	23
Max. input current with rated output power and discharged battery per module (output Cosφ = 1.0)	A	16.6	33.3
Output characteristics		10KW UPS Module	20KW UPS Module
Output rated power cosφ 1.0	KW	10	20
Output current @ cosφ 1.0 (400 V)	A	14.5	29
Overload capability on inverter	%	125% load 10 min. / 150% load 60 sec.	
Output short capability (RMS)	A	Inverter: 3 x In during 40 ms Bypass: 10 x In during 20 ms	
Environmental		10KW UPS Module	20KW UPS Module
Heat dissipation with 100% non-linear load per module (EN 62040-1-1:2003)	W	550	1100
	BTU/h	1887	3754
Airflow (25° - 30°C) with non-linear load per module (EN 62040-1-1:2003)	m³/h	150	150
Dissipation at no load	W	120	150
Audible noise with 100% / 50% Load	dBA	55 / 49	57 / 49

Battery data

Battery characteristics		10KW UPS Module	20KW UPS Module
Variable number of 12v battery blocks	No.	30-50	40-50
Maximum battery charger current	A	4 A (6A Charger is optional)	
Battery charging curve		Ripple free: IU (DIN 41773)	
Temperature compensation		Standard (temp. sensor optional)	
Battery test		Automatic and periodically (adjustable)	
Battery type		VRLA or NiCd	

Battery capacity usage	10KW UPS Module			20KW UPS Module		
Number of battery blocks	30-32	30-32	34-50	40-46	40-46	48-50
Max. Power in KW	6	10	10	16	20	20
Max. autonomy (min.)	any	5	any	any	5	any

Standards

Compliant standards	
Safety	EN 62040-1-1, EN 60950-1
Electromagnetic compatibility	EN 61000-6-4 Prod.standard: EN 62040-2 EN 61000-6-2 Prod.standard: EN 62040-2 EN 61000-4-2, EN 61000-4-3 - EN 61000-4-4 - EN 61000-4-5 - EN 61000-4-6
Emission class	C3
Immunity class	C3
Performance	EN62040-3
Product certification	CE
Degree of protection	IP 20

Options

Communications options fitted as standard	
RJ45 Plug (Not used)	RJ45 Plug (for future options)
Customer interfaces: outputs DRY PORT X2	5 Voltage free contacts For remote signalling and automatic computer shutdown
Customer interfaces: inputs DRY PORT X1	1 x Remote Shut-down [EMERGENCY OFF (normally closed)] 1 x Programmable Customer Inputs 1 x GEN-ON (normally open) 1 x Temperature sensor for battery charging control 1 x 12Vdc output (max 200mA)
Serial ports RS232 on Sub-D9	1 x system frame For monitoring integration in network management and service
USB	1x For monitoring and software management
Slot for SNMP card	For monitoring and integration in network management
Slot for modem/ethernet card	For monitoring and integration in network management

Multi-cabinet configuration

The PowerWAVE PW8000DPA ST Series 2 may be paralleled to increase the power capacity up to 400kW in steps of 10 or 20kW. A maximum of 20 modules can be paralleled, into four UPS cabinets.

The following system configurations are available

PW8000DPA ST Series 2 system	ST-40	ST-60	ST-80	ST-120	ST-200
Number of modules per cabinet	2	3	4	6	10
Parallel cabinets per system	4	4	4	3	2
Maximum number of modules per system	8	12	16	18	20
Maximum total system capacity w/o redundancy	160kW	240kW	320kW	360kW	400kW

The following options are required for a multi-cabinet system:

Input power source

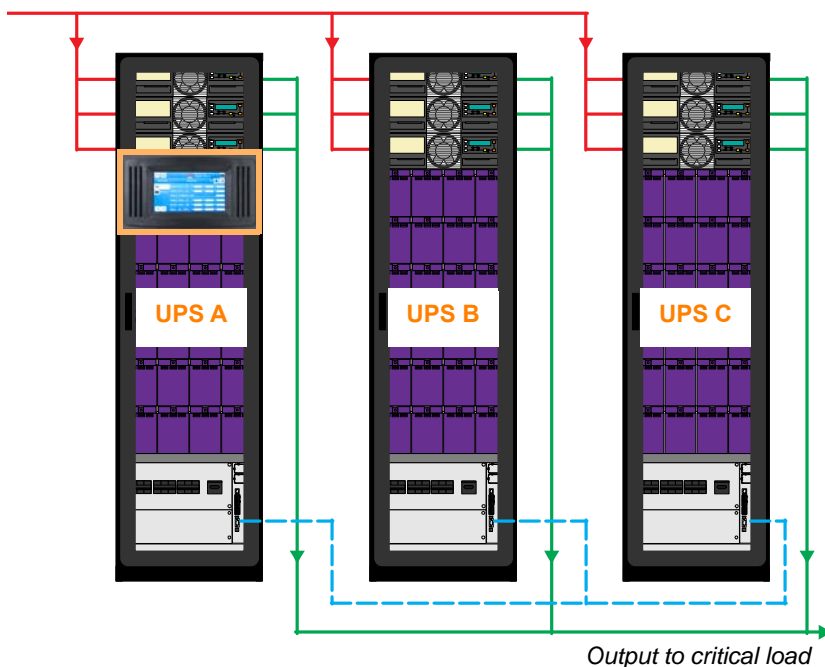

UPS Cabinet	A	B	C
System graphical display	X	–	–
Parallel interface adapter.	X	X	X
Parallel cable	X	X	–

UPS CONTROLS

Module Control Panel

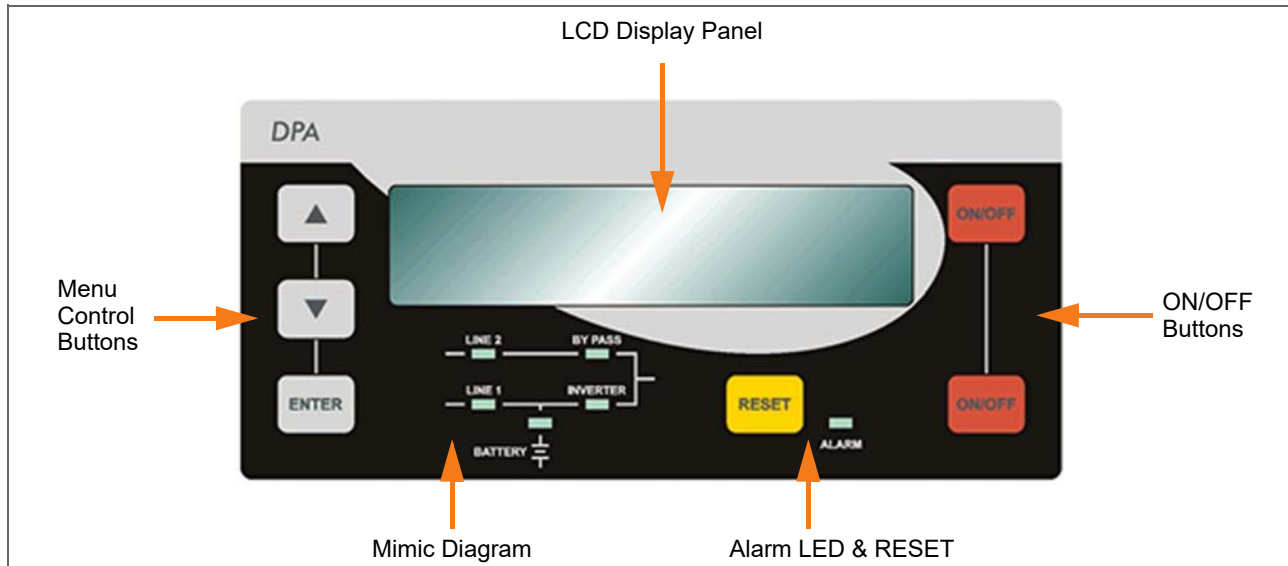

A Module control panel, shown above, is fitted to each UPS module to provide independent monitoring and module control.

Mimic Diagram

The mimic diagram contains multi-coloured LEDs that change between Green, Red and Off to indicate the UPS operational power flow status.

LEDs LINE 1 and LINE 2 indicate the availability of the input mains and bypass mains power supplies respectively, and are both Green during normal operation.

The INVERTER and BYPASS LEDs indicate which of the two power sources is providing the critical load supply. These LEDs illuminate Green to indicate which is the active supply source.

The BATTERY LED indicator shows solid Green when the battery is being charged and flashes when the battery is discharging –e.g. when the battery is providing the load power during a mains failure.

The ALARM LED, located at the lower-centre area of the Module control panel, is a visual indication of any monitored internal or external alarm condition. When activated, it is accompanied by an audible alarm that can be cancelled using the RESET button.

LCD Display Panel

A 2 x 20 character multi-function LCD Display provides a simple communications interface that enables the operator to monitor important UPS operating parameters and alarm warnings. It also allows the operator to undertake various control operations such as transferring the load between the inverter and bypass. The display is menu-driven using the UP/DOWN and ENTER buttons.

LCD Display Panel summary:

- Displays the input and output voltage, current, frequency and power.
- Displays an 'Event register' which stores a date/time stamped history of the 99 most recent alarms and events.
- Enables battery run time monitoring.
- Enables selection of commands such as load transfer from inverter to bypass and vice-versa, and battery test.
- Provides diagnostic facilities (service mode only).
- In conjunction with the operator keys, provides Module adjustments and testing facilities (service mode only).

ON/OFF Control Buttons

The two ON/OFF control buttons must be pressed simultaneously in order to turn ON or OFF the Module. These buttons are duplicated to reduce the likelihood of inadvertent operation.

Optional System Control Panel

The system control panel is an optional component which can be fitted to one UPS cabinet, usually the 'master' UPS, in a parallel cabinet system.

It contains a microprocessor-based TFT touch-screen display which enables the operator to monitor the status of the overall UPS system as well as the individual UPS modules within any cabinet. It also allows the operator to transfer the load between the inverter and bypass but all other UPS module-level commands must be performed from an individual module's control panel. By having both control panels in place, working at 'module' and 'system' level, the UPS offers enhanced user friendliness without compromising on robustness.



Using the touch-screen display the operator can:

- execute system-level commands.
- check alarm and events history.
- silence alarms.
- view the battery status.
- monitor the power flow through the UPS system.
- check system's operational status and measurements.
- adjust programmable parameters.

The display turns on automatically when the first UPS power module is energised; and after a few seconds of initialisation it displays the default module mimic screen shown below.

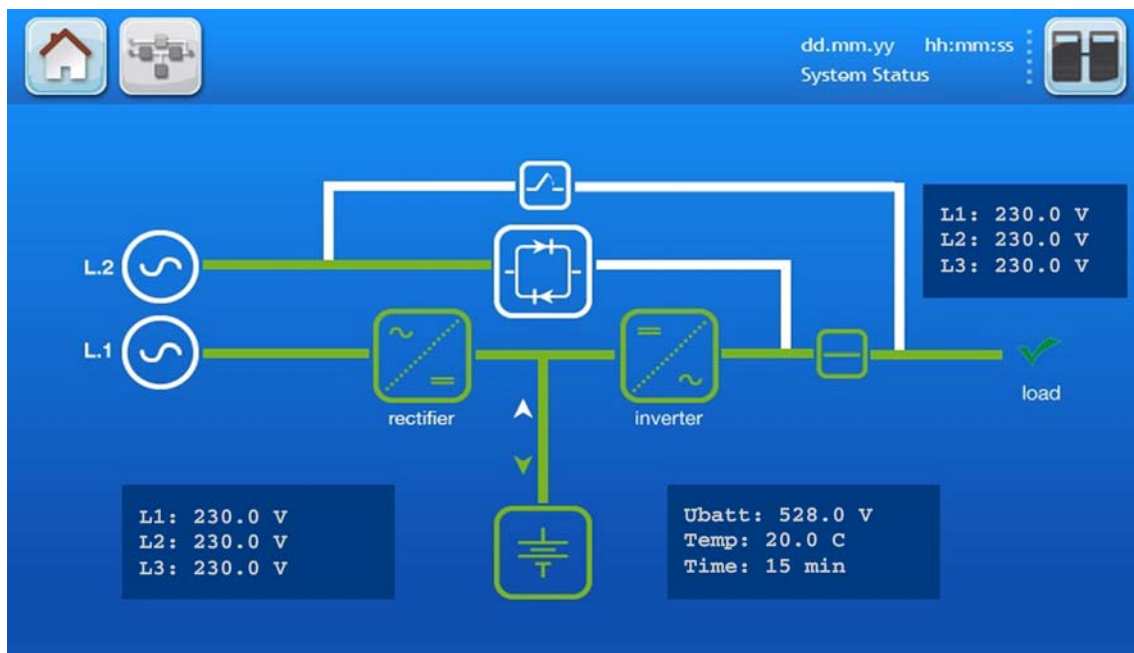

UPS Interface boards

Two interface boards are fitted in the lower part of the UPS cabinet, adjacent to the Maintenance Bypass switch. One is the Customer Interface Board, which provides a means of connecting the UPS cabinet to a range of external monitoring and control facilities. The other is the Parallel Interface Board which contains the connections used to control and monitor the cabinets when connected as part of a parallel cabinet system.



The Parallel Interface Board is part of the factory-fitted 'paralleling kit' and is installed only in UPS cabinets used in a parallel system.

Customer Interface Board

The Customer Interface Board provides a number of input/output interface connections that can be used by the customer to facilitate external monitoring and control of the UPS system – e.g. as part as a building management system (BMS).

The available interfaces include:

- Two SNMP\CS141 card slots
- RS485 interface via an RJ45 network connector (JR2)
- Relay operated dry-port alarm outputs for remote monitoring (X2)
- Dry-port inputs for customer remote control options (X1)
- RS232 computer interface for remote monitoring/control applications (JD1)
- USB port for computer monitoring applications

Dry-port input interfaces connected to terminal block X1

Terminal block X1 provides a means of connecting optional control inputs to the UPS system. All connections are made to Phoenix terminals using cable 0.2 mm² - 1.5 mm² (max.).

Dry-port output interfaces connected to terminal block X2

Terminal block X2 provides a means of connecting switched outputs for use by remote signalling and/or monitoring applications such as a customer's buildings management facilities. All contacts are voltage free and rated at 60 VAC max. and 500 mA.



Key Point: When the UPS cabinet is installed as part of a parallel system the Customer Interface Board I/O is disabled in the 'slave' cabinets if the system 'Multidrop' application is enabled.

Parallel Interface Board

The Parallel Interface Board is primarily used to facilitate the connection of the parallel control bus cables between the cabinets in a parallel system. The parallel bus cables (25-way D-type ribbon cables) are connected to a 'Parallel Adapter' board which is fitted to the Parallel Interface Board JD8.

Two terminal blocks are fitted to the Parallel Interface Board.

- Terminal block X1: The PW8000DPA ST S2 has an optional 'Synchronisation Feature' which enables it to synchronise to any other UPS system. This feature requires other factory-installed modifications and, when enabled, the 'line' supply of the external source is connected to X1 where it acts as a synchronisation reference.
- Terminal block X2: Is connected to the auxiliary contacts of an optionally installed external maintenance bypass switch and/or external output isolator. This allows the UPS to detect the status of the external switch(s) and react accordingly.

In a parallel system, one cabinet acts as the 'master' cabinet and the remaining cabinets act as the slave. The master/slave configuration is set by DIP switch S1-6.

Multidrop

The optional 'Multidrop' feature, which is available only in a parallel system, allows the Customer Interface Board in the 'master' cabinet to collect data/messages from the other system cabinets via the parallel control bus cables and Parallel Interface Boards.

The received data is processed at a centralised point on the 'master' Customer Interface Board and made available to the user directly on the RS232 port (JD1). It is also transmitted to the SNMP/CS141 card if inserted in the relevant slot.

ST200 Cabinet

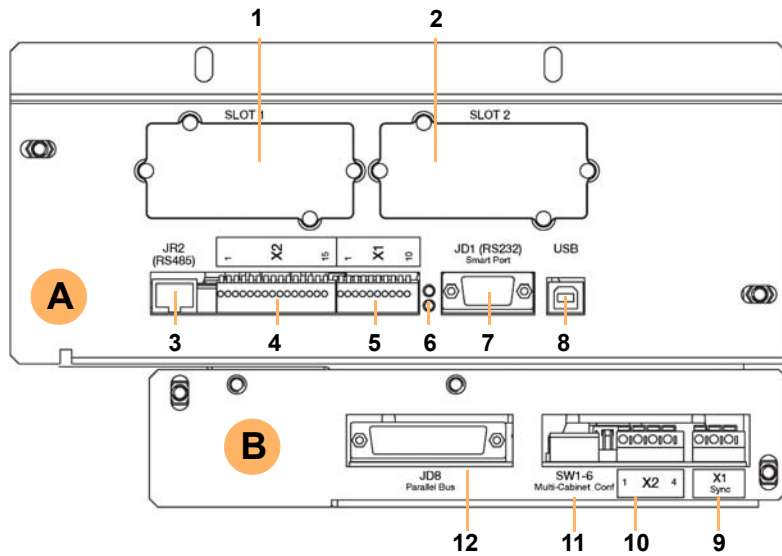

ST40-120 Cabinet

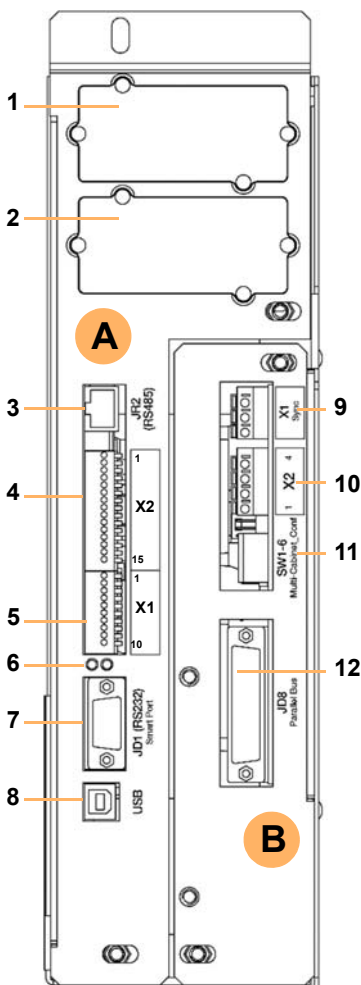

A Customer Interface Board		
1	SLOT 1	Slot for optional modem/ethernet card ONLY.
2	SLOT 2	Slot for optional SNMP card ONLY.
3	JR2	RJ45 Port:
4	X2	Customer output dry ports: Up to 5 output dry contacts used for signalling of the status of the UPS system (e.g. Mains failure, load on inverter, battery low, common alarm).
5	X1	Customer input dry ports: Up to 5 input dry contacts used for remote Shut Down and Generator Operation facilities, battery temp sensor or bespoke customer function.
6	LEDs	Status LEDs: 2 LEDs that indicate the Interface Board operational status.
7	JD1	RS232 Smart port computer interface: Sub D9 female connector provides an RS232 user interface for remote systems monitoring.
8	USB	Standard USB interface: Provides a USB user interface for remote systems monitoring.
B Parallel Interface Board (fitted in a parallel UPS cabinet only)		
9	X1	Sync Input: Allows external synchronisation control source.
10	X2	External manual bypass: Auxiliary signals from external manual bypass switch and external output breaker providing open/close status information for parallel system configuration
11	S1-6	Multi-cabinet configuration DIP switch: Used to configure the cabinet position in a parallel system.
12	JD8	Parallel bus: Attached to the Parallel Adapter Board, which provides the parallel communications bus in a parallel system

Terminal	Contact	Signal	Function	
Customer Interface Board Input port (X1)	X1/1	IN ← ○	+12Vdc	Customer IN 1 (default as ONGENERATOR operation) (NC = Generator ON)
	X1/2	GND ● ○	Gnd	
	X1/3	IN ← ○	+12Vdc	Customer IN 2 (Function on request, to be defined on purchase)
	X1/4	GND ● ○	Gnd	
	X1/5	IN ← ○	+3.3Vdc	Battery Temperature If connected, the battery charger voltage is temperature dependent
	X1/6	GND ● ○	Gnd	
	X1/7	IN ← ○	+12Vdc	Remote shutdown
	X1/8	GND ● ○	Gnd	
	X1/9	OUT ○ →	+12Vdc	12Vdc source Max 200mA load
	X1/10	GND ● ○	Gnd	

Pin	Contact	Signal	Function		
Customer Interface Board Output port (X2)	X2/1		Alarm	MAINS_OK	Mains Present
	X2/2				Mains Failure
	X2/3				Common
	X2/4		Message	LOAD_ON_INV	Load On Inverter
	X2/5				Load Not On Inverter
	X2/6				Common
	X2/7		Alarm	BATT_LOW	Battery Low
	X2/8				Battery OK
	X2/9				Common
	X2/10		Message	LOAD_ON_MAINS	Load On Static Bypass
	X2/11				Load Not On Static Bypass
	X2/12				Common
	X2/13		Alarm	COMMON_ALARM	Common Alarm
	X2/14				No Alarm Condition
	X2/15				Common

Parallel Interface Board I/O terminals	Terminal	Contact	Signal	Function
	X1/L1	IN ← ○	L1	'Synchronisation Feature' Option (Line connection)
	X1			
	X1/N	GND ● ○	N	
	X2/4	GND ● ○	Gnd	External Output Isolator (IA1) Option (Min. contact load 12V/20mA) When external output isolator is open
	X2/3	IN ← ○	12Vdc	
	X2/2	GND ● ○	Gnd	External Maintenance Bypass switch (IA1) Option Min. contact load 20mA
	X2/1	IN ← ○	18Vdc	

CS141 Card slots

Simple Network Management Protocol (SNMP) is a world-wide, standardised communication protocol that can be used to monitor any network-connected device via a simple control language and display the results in an application running within a standard web browser.

The PowerWAVE PW8000DPA ST Series 2 contains two SNMP slots; one is designed to house a Modem/Ethernet SNMP adapter card and the other a Modem/GSM adapter. Alternatively, SNMP connectivity can also be implemented using an external SNMP adapter connected to the UPS RS232 output (JD1).

An SNMP/Ethernet adapter contains an RJ-45 connector

which allows it to be connected to the network using a standard network cable. Once connected, the UPS-Management software agent, which is already installed in the SNMP adapter, then monitors the UPS operating parameters. In a multi-module UPS system the SNMP interface can communicate 'system-wide' data or data for an individual UPS module.

The SNMP card enables event/alarm emails, server shutdown (with optional licenses) and other tasks. The SNMP card can also be integrated with BMS software over a local area network (LAN) for SNMP or Modbus information over IP. An optional card enables Modbus comms over RS485.

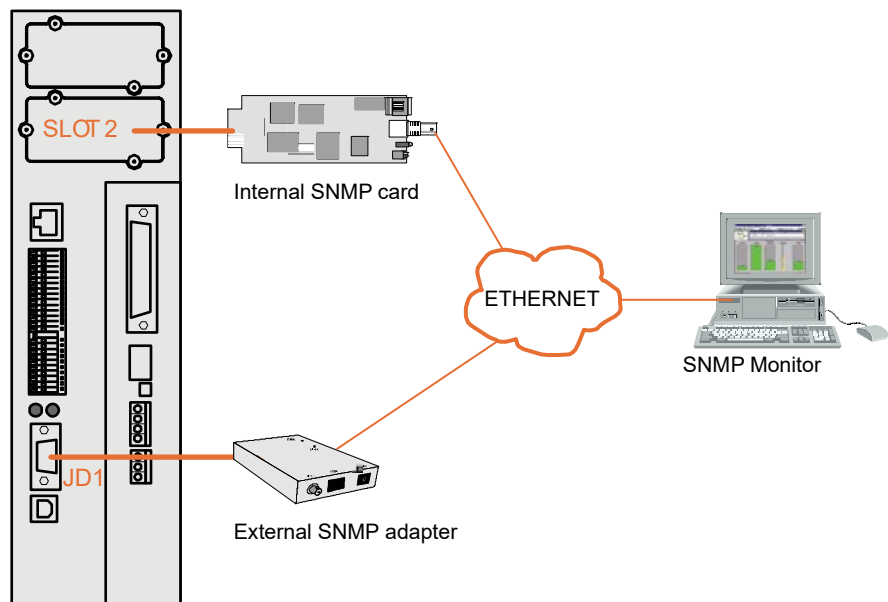

INSTALLATION PLANNING

A certain amount of pre-planning will help ensure smooth, trouble-free equipment installation. The following guidelines should be taken into account when planning a suitable UPS location and environment.

Location considerations summary

- The equipment must be installed and transported in a upright position.
- The floor at the installed location and en-route from the off-loading point must be able to safely take the weight of the UPS and battery equipment plus fork lift during transit.
- The UPS cabinet requires space to bottom/front, top and back to enable cooling airflow, as shown in the following diagrams The ST200 battery circuit breaker is located on the back of the cabinet and suitable access must be provided to operate the breaker. Two alternative installation layouts are shown.
- A minimum clearance of 200mm must be provided at the back of the cabinet to provide adequate ventilation. A clearance of 400mm should also be provided at the top of the cabinet if there is in insufficient route at the back of the cabinet to dissipate the cooling airflow.
- All parts of the UPS required for maintenance, servicing and user operation are accessible from the front. Reserve a minimum of 1000mm space at the front of the UPS cabinet. Note also that the cabinet right-hand door must be opened by 115° in order to remove/fit the UPS power modules so the right-hand side of the cabinet cannot be positioned directly against a wall.
- An ambient temperature of 20°C is necessary to achieve the recommended life span. The cooling air entering the UPS must not exceed +40°C.
- Avoid high ambient temperature, moisture and humidity. The floor material should be non-flammable and strong enough to support the heavy load.

Environmental considerations summary

- Avoid high ambient temperature, moisture and humidity. The prescribed limits are humidity (<90% non-condensing) and temperature (0°C to +40°C and ideally 20°C to 25°C).
- An ambient temperature of 20°C is recommended to achieve a long battery life.
- Any prescribed air cooling flow must be available. Ensure the air conditioning system can provide a sufficient amount of air cooling to keep the room at, or below, the maximum desired temperature.
- Ensure no dust or corrosive/explosive gases are present.
- Ensure the location is vibration-free.

CLEARANCES

The diagrams below illustrate the required clearances that must be provided around the UPS and external battery cabinet. All parts of the UPS that require access for maintenance, servicing and user operation are accessible from the front of the cabinet. Ensure that all ventilation ports are kept free of obstruction.

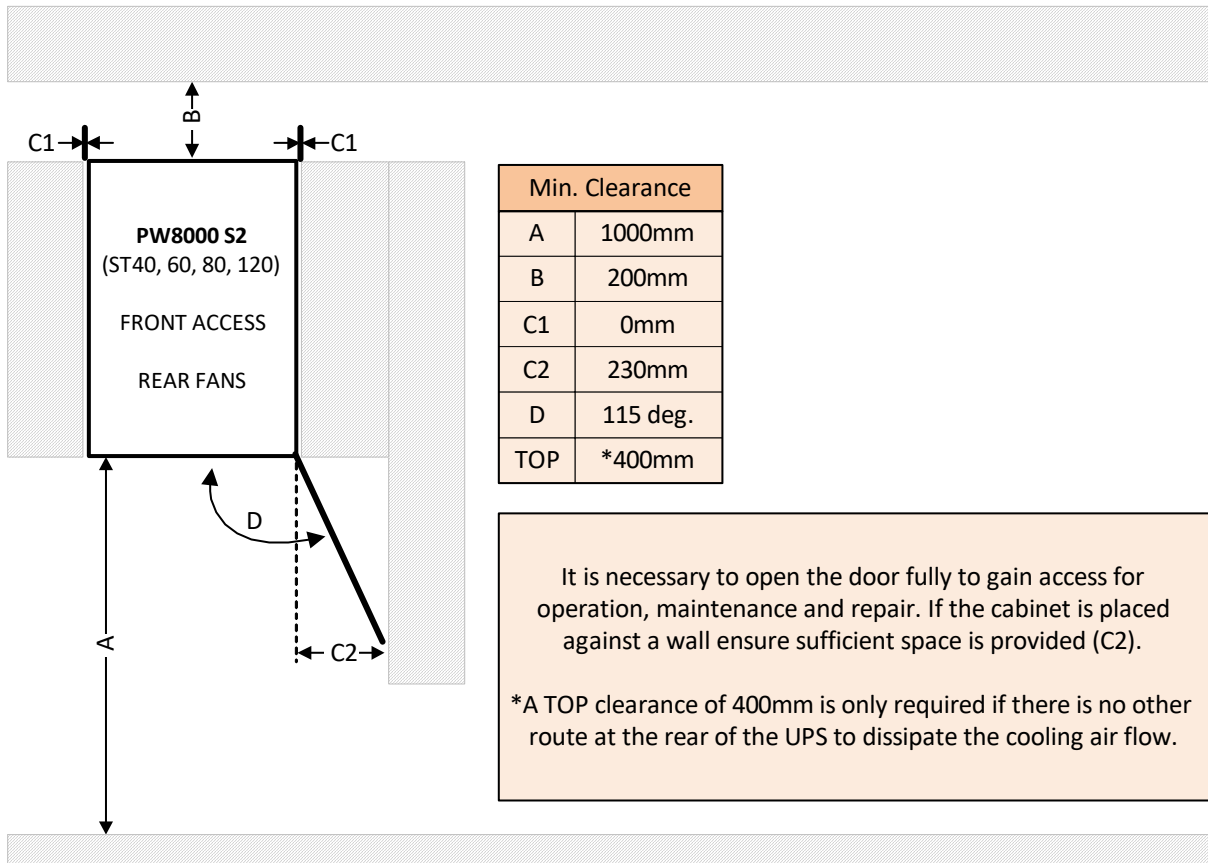

	ST-40	ST-60	ST-80	ST-120	ST-200
Dimensions (WxHxD) mm	550 x 1135 x 770	550 x 1975 x 770	550 x 1135 x 770	550 x 1975 x 770	550 x 1975 x 770
Maintenance Accessibility	*Totally front accessibility for service and maintenance (no side, top or rear access required)				
Input/Output Power Cabling	From the bottom				

***Note:** The battery fuses are located on the back of the ST-200 cabinet and rear access is required to operate the equipment. See below for optional installation positioning of the ST200 cabinet.

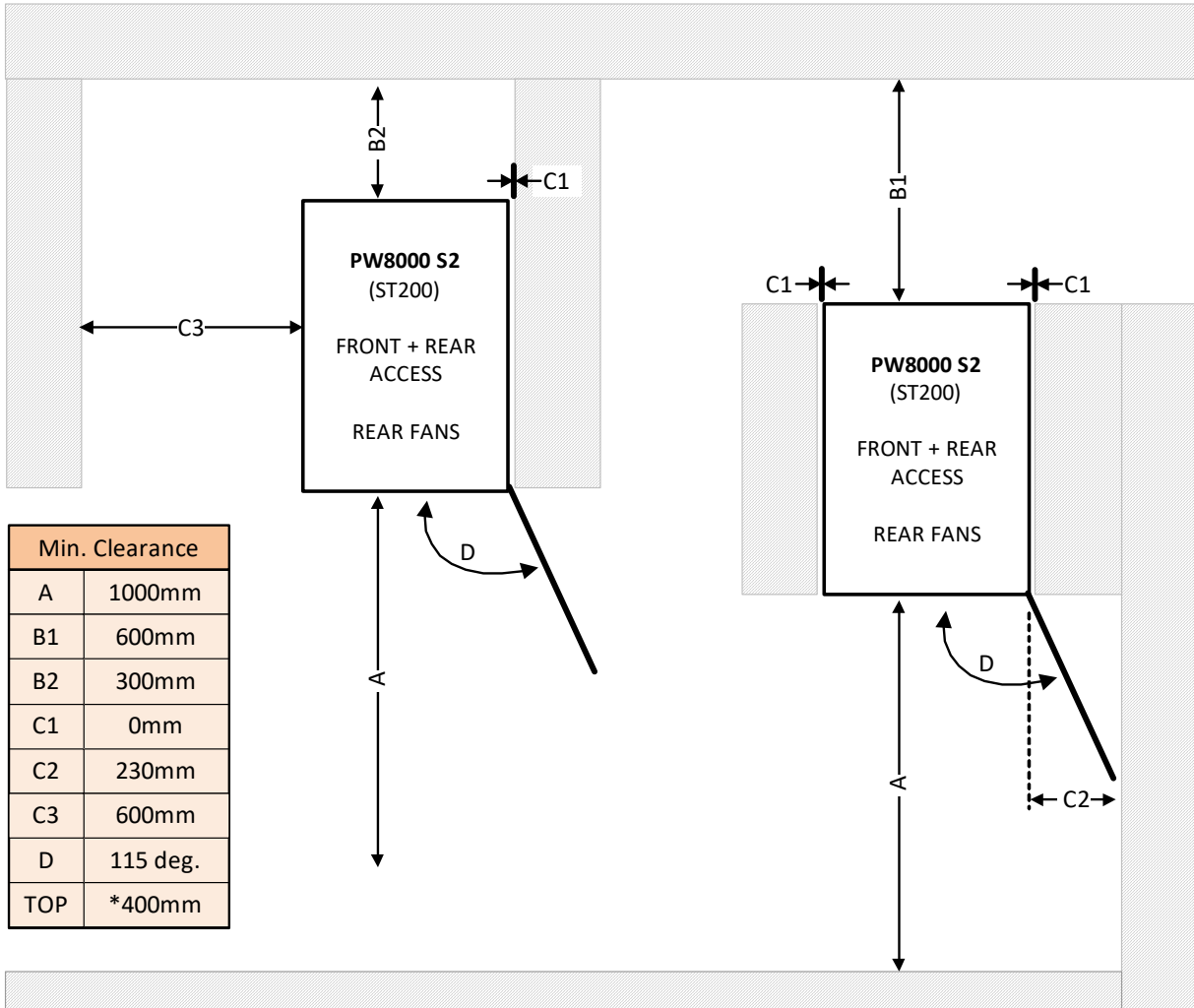

It is necessary to fully open the cabinet door to gain access for operation, maintenance and repair. This requires a minimum front clearance of 1000 mm and if the cabinet is placed against a wall a sufficient side clearance must be provided to allow the door to open through a 115° arc (C2).

Rear access is required to operate the ST200 battery fuses.

If there is free passage behind the cabinet a minimum rear clearance of 600mm is required in order to safely access the fuses (B1). Alternatively, a side clearance of 600mm (C3) and rear clearance of 300mm (B2) should be provided.

*A TOP clearance of 400mm is only required if there is no other route at the rear of the UPS to dissipate the cooling airflow.

UPS POWER CABLING

The UPS can be wired for a 'single feed' or 'dual feed' input. In a 'single feed' system (standard) the UPS input supply terminals and bypass supply terminals are internally linked together but in a 'dual feed' system the bypass terminals are connected to a dedicated 'bypass' mains supply.

All input and bypass mains cables should be connected through a LV-Distribution board and protected by a circuit breaker or fuse to provide overload protection and a means of isolating the UPS from the mains supply if required. Similarly, the UPS output cables should be connected to the load equipment via a suitably fused load distribution panel.



Key Point: It is the customer's responsibility to provide all the external fuses, isolators and cables used to connect the UPS input and output power supplies. The following diagrams identify the UPS input/output cabling requirements and provides information regarding the necessary fuse and cable ratings, and cable sizing.

Power connection terminals

All the UPS input/output power cables are connected to a row of terminal blocks mounted on a DIN rail located at the bottom of the cabinet, except for the ST-200 model which uses busbars connections (shown opposite). All power connections are accessible from the front of the UPS cabinet.

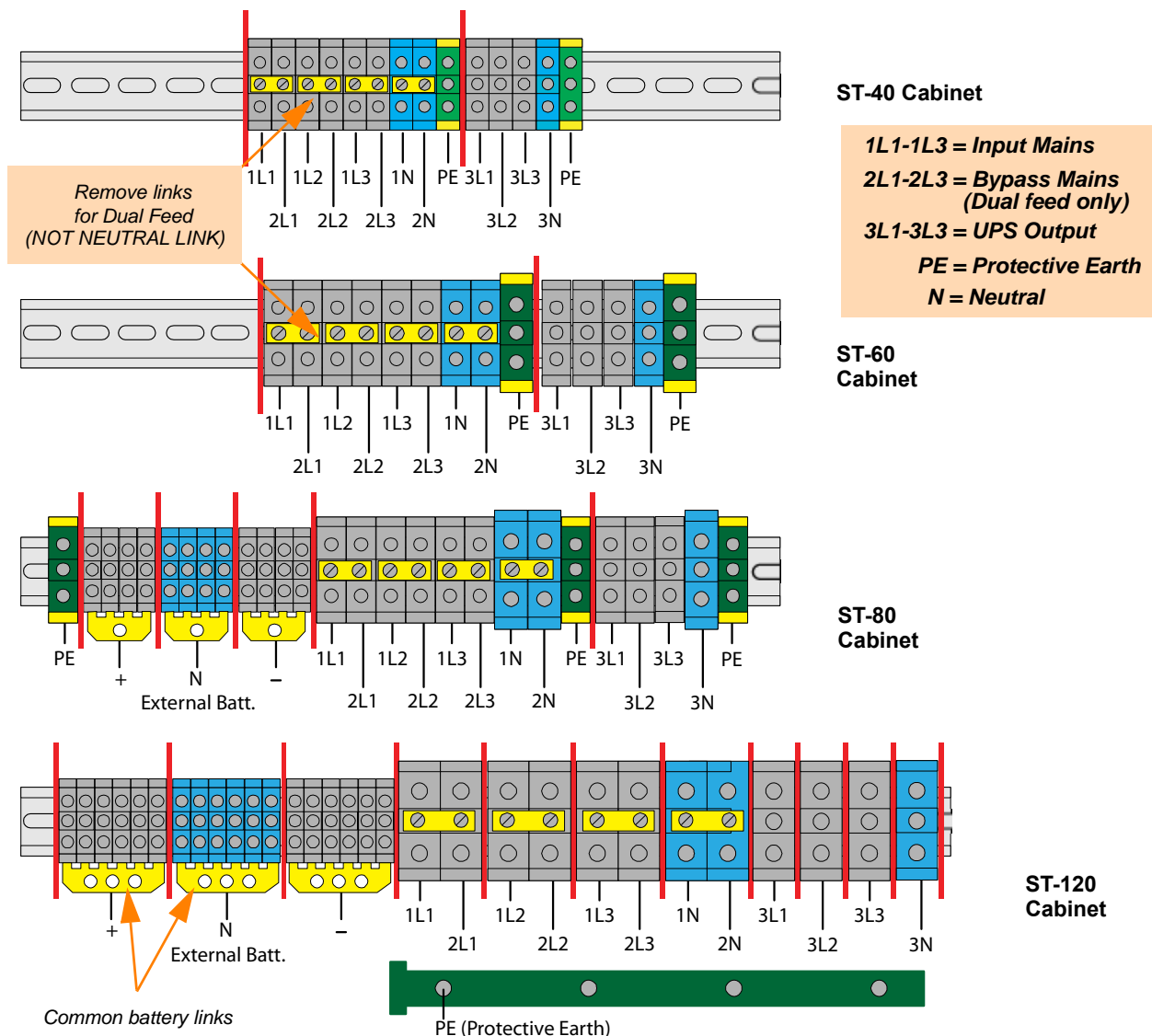

ST-200 Cabinet

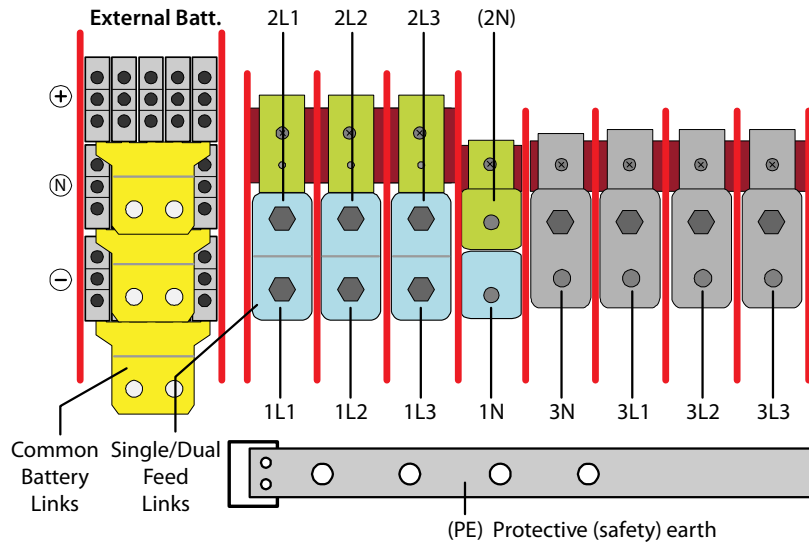

1L1-1L3 = Input Mains
2L1-2L3 = Bypass Mains (Dual feed only)
3L1-3L3 = UPS Output
PE = Protective Earth
N = Neutral

Remove links for separate battery installation and connect batteries to individual terminals.
Note that when using individual batteries, each battery is connected to two UPS modules.

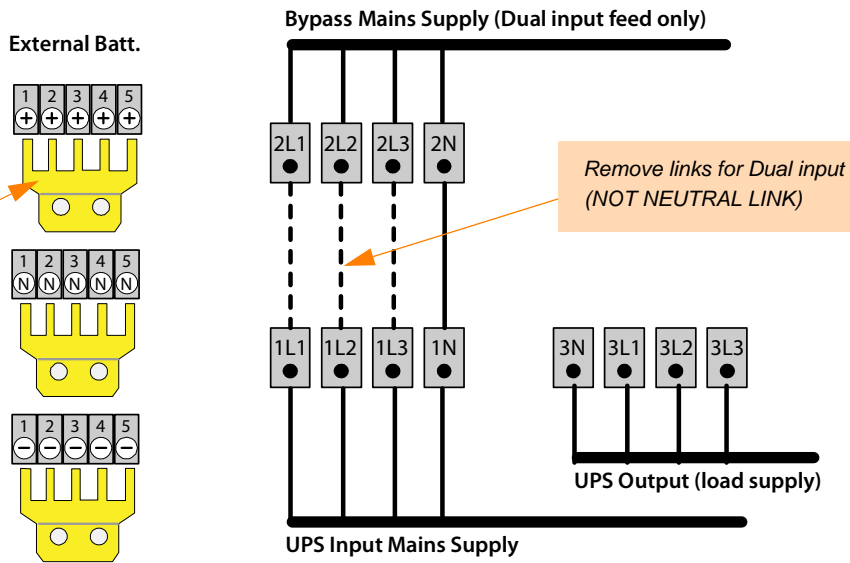

Single feed links

In a 'single feed' (standard) installation the input and bypass supply terminals are connected together by links fitted on the top of the terminal blocks, as shown in the upper illustration. These links must be removed if the UPS is to be used with a 'dual feed' supply. Note that the input/bypass Neutral link must be fitted in all cases.

Common battery links

If a 'common battery' configuration is used, all the UPS modules are connected to a common battery source comprising a number of parallel battery strings each of which is connected to the common battery links fitted to the bottom of the battery terminals.

Where an individual battery configuration is used, the common battery links are removed and the individual battery strings are connected to their respective UPS module's battery connections.

Cable sizing

The table below shows the maximum UPS input and output current together with the UPS cable termination details. This is provided to assist the customer in selecting the appropriate UPS power cables and external switchgear.

	400V / 230V						BATTERY		
	UPS INPUT MAINS (Rectifier)		UPS BYPASS MAINS (Bypass)		UPS OUTPUT		PE	Separate	Common
	Max. Amps	Terminal (mm ²)	Max. Amps	Terminal (mm ²)	Max. Amps	Terminal (mm ²)	Terminal (mm ²)	Terminal (mm ²)	Terminal (mm ²)
ST-40	68	3x 25 (T) 1x 25 (N)(T) 1x 25 (PE)(T)	68	3x 25 (T) 1x 25 (N)(T)	58	3x 25 (T) 1x 25 (N)(T) 1x 25 (PE)(T)			
ST-60	102	3x 35 (T) 1x 35 (N)(T) 1x 50 (PE)(T)	102	3x 35 (T) 1x 35 (N)(T)	87	3x 35 (T) 1x 35 (N)(T) 1x 50 (PE)(T)			
ST-80	136	3x 50 (T) 1x 50 (N)(T) 1x 50 (PE)(T)	136	3x 50 (T) 1x 50 (N)(T)	116	3x 50 (T) 1x 50 (N)(T) 1x 50 (PE)(T)	1x 50 (T)	3x (4x16) (T)	3x M6 (B)
ST-120	208	3x 95 (T) 1x 95 (N)(T) 1x M10 (PE)(B)	208	3x 95 (T) 1x 95 (N)(T)	174	3x 95 (T) 1x 95 (N)(T) 1x M10 (PE)(B)	1x M10 (B)	3x (6x 16) (T)	3x (2xM5) or 3x M10 (B)
ST-200	333	3x M12 (B) 1x M12 (N)(B) 1x M12 (PE)(B)	333	3x M12 (B) 1x M12 (N)(B)	290	3x M12 (B) 1x M12 (N)(B) 1x M12 (PE)(B)	1x M10 (B)	3x (5x35) (T)*	3x (2xM10) (B)

(PE) = Protective Earth
 (N) = Neutral
 (B) = Busbar connections with indicated bolt size. Cable must be terminated with a suitable lug.
 (T) = Screwed terminal block with indicated maximum cable c.s.a. Cables must be suitably prepared.
 * In the ST-200 model with individual battery configuration, each battery feeds two UPS modules.

Notes:

1. The UPS must be installed to prescribed IEC or local regulations (e.g. BS7671:2008).
2. Where external batteries are used, DC Cables and Battery fuses are bespoke to the installation.