

PowerWAVE 3000/TP (10 & 20 kVA)

User Manual

Document Control

ISSUE	DATE	REVISION SUMMARY
463-01-00	01/08/2014	Initial draft copy.
463-01-01	05/09/2014	Initial issue
463-01-02	25/09/2014	Cable sizing tables corrected and updated to include design note.
463-01-03	02/10/2014	Optional Operating Mode Setting details added to CH-2.
463-01-04	20/12/2014	Updated 3 phase input single feed connection details and cabling instructions
463-01-05	09/02/2015	General update to correct previous errors
463-01-06	11/10/2015	General update and revision of control panel, installation and specification details
463-01-07	16/05/2017	Update terminal block details and jumper. Reduce max. cable size to 25mm
TS_604_00A	29/05/17	Applied new document cover and updated document to TS_604_XX series
TS_604_00B	21/06/17	Applied changes from TS_604_00A mark-up and updated document layout
TS_604_00	28/06/17	Applied changes from TS_604_00B mark-up and issued as new release document

USEFUL CONTACTS

www.upspower.co.uk	UPS Limited web site
service@upspower.co.uk	Service department – booking service, fault reporting etc.
technical@upspower.co.uk	Technical queries
sales@upspower.co.uk	Hardware sales
servicesales@upspower.co.uk	Extended warranty agreements etc

Uninterruptible Power Supplies Ltd has taken every precaution to produce an accurate, complete and easy to understand manual and will therefore assume no responsibility nor liability for direct, indirect or accidental personal or material damage due to any misinterpretation of or accidental mistakes in this manual.

© 2017 Uninterruptible Power Supplies Ltd

This manual may not be copied nor reproduced without written permission of Uninterruptible Power Supplies Ltd.

Table of Contents

Safety	1
1.1 Description of symbols used in this manual	1
1.2 User precautions	1
1.3 Declaration of Safety conformity and CE marking	2
General Description	3
2.1 Introduction	3
2.2 PowerWave PW3000/TP Model range	4
2.3 Functional description of operation	4
2.3.1 PowerWave PW3000/TP Module block diagram	4
2.3.2 UPS Module operating modes	6
2.3.3 UPS System operating modes	8
2.3.4 Optional operating mode settings	9
2.3.5 Multi-module parallel system operation	9
2.4 PowerWave PW3000/TP User controls	10
2.5 UPS Control panel	12
2.5.1 Status LED indicators	12
2.5.2 LCD Display	12
2.5.3 UPS Control panel operator keys	14
2.5.4 LCD Menu navigation	14
2.5.5 Main Menu	14
2.5.6 Status sub-menu	15
2.5.7 Event Log sub-menu	15
2.5.8 Measurements sub-menu	15
2.5.9 Control sub-menu	16
2.5.10 Identification sub-menu	18
2.5.11 Settings sub-menu	18
2.6 Warranty	22
2.7 Extended Warranty	22
2.8 Additional Service/Maintenance Support	22
Installation	23
3.1 Introduction	23
3.2 Taking receipt of the UPS	23
3.2.1 Site transportation	24
3.3 Unpacking	24
3.4 Storage	25
3.5 Planning the installation (site considerations)	25
3.5.1 Clearances	26
3.6 Planning the installation (cabling considerations)	26
3.6.1 General requirements	26
3.6.2 UPS Cable and fuse sizing	27
3.6.3 Power cabling for a parallel system	27
3.6.4 UPS Terminal block connection details	28
3.6.5 Input/bypass supply configuration options	28

3.7	Connecting the UPS power cables	29
3.7.1	Power cabling procedure	29
3.7.2	Three phase dual input cabling details	30
3.7.3	Three phase single input cabling details	31
3.7.4	Single phase dual input cabling details	32
3.7.5	Single phase single input cabling details	33
3.8	Battery cabling procedure	34
3.8.1	Internal battery connections	34
3.8.2	External battery cabinet cabling procedure	35
3.9	Multi-cabinet configuration and paralleling cables	35
3.10	Optional remote monitoring and control facilities	35
	Operating procedures	36
4.1	Introduction	36
4.1.1	Operating procedure summary	36
4.2	Single module start-up – with mains supply	37
4.3	Single module start-up – without mains supply	37
4.4	Single module – changing the operating mode	38
4.5	Single module shut down – with mains supply present	38
4.6	Single module shutdown – with UPS on battery	38
4.7	Single module – using the internal maintenance bypass	39
4.8	Parallel module system procedures	40
4.9	Parallel system start-up	41
4.10	Parallel system – changing the operating mode	41
4.11	Parallel system – start/stop one module	42
4.12	Parallel module complete system shut-down	43
4.13	External Maintenance Bypass operation	44
4.14	Operating a frequency changing system	45
4.14.1	Frequency changer – starting the UPS	45
4.14.2	Frequency changer – stopping the UPS	45
4.15	Emergency Stop	46
	Maintenance	47
5.1	Introduction	47
5.2	System calibration	47
5.3	User responsibilities	47
5.4	Routine maintenance	47
5.5	Battery testing	48
5.6	Battery maintenance	48
5.7	Battery disposal and recycling	48
	Troubleshooting	49
6.1	Contacting Service	49
6.2	Fault identification and rectification	50
6.2.1	Troubleshooting without an error message	50
6.2.2	Troubleshooting based on error message	50
	Options	52
7.1	Back-feed protection	52
7.2	Emergency Power-OFF (EPO)	53
7.3	Computer communication options.	53
7.3.1	USB Port	53
7.3.2	RS232 Port.RS232 and USB Communication options	54
7.4	Serial Network Management (SNMP) card	54

7.5 AS400 Interface card	55
7.6 UPS Monitoring and automated control software	56
7.6.1 The importance of UPS management	56
Specifications	57

1 Safety

1.1 Description of symbols used in this manual



WARNING: The warning symbol is used where there is danger of an electrical shock, equipment damage or personal-injury.



CAUTION: The caution symbol is used to highlight important information to avoid possible equipment malfunction or damage.

1.2 User precautions



WARNING: Keep this manual with the UPS for future reference.



WARNING: The UPS and peripheral equipment must be installed and commissioned by suitably qualified and trained personnel who are aware of the potential shock hazards.



WARNING: Do not attempt to install this UPS system until you are satisfied that ALL the safety instructions and hazard warnings contained in this manual are read and fully understood.



WARNING: High leakage current!
Ensure that the UPS has been correctly earthed before you connect the mains power supply!



WARNING: This UPS must not be started-up or put into use without having first been commissioned by a fully trained engineer authorised by the manufacturer.



WARNING: This UPS must be serviced by qualified personnel.
You run risk of exposure to dangerous voltages by opening or removing the UPS-covers! Uninterruptible Power Supplies Ltd will assume no responsibility nor liability due to incorrect operation or manipulation of the UPS.



WARNING: The PowerWave PW3000/TP is a Class A UPS product (according to EN 62040-3). In a domestic environment the UPS may cause radio interference.
In such an environment the user may be required to undertake additional measures.

1.3 Declaration of Safety conformity and CE marking

The PowerWave PW3000/TP UPS system is designed and manufactured in accordance with Quality Management Systems standard EN ISO 9001. The CE marking indicates conformity to the EEC Directive by the application of the following standards in accordance with the specifications of the harmonized standards:

- 2006/95/EC Low voltage directive
- 2004/108/EC Electromagnetic Compatibility directive (EMC)

Standards as reference:

- EN-IEC 62040-1 – Uninterruptible power supply (UPS). Part 1-1: General and safety requirements for UPSs used in accessible areas by end users.
- EN-IEC 60950-1 – IT equipment. Safety. Part 1: General requirements
- EN-IEC 62040-2 – Uninterruptible power supply (UPS). Part 2: EMC requirements
- EN-IEC 62040-3 – Uninterruptible power systems (UPS). Part 3: Performance and test requirements
- 2011/65/EU – Restriction of the use of certain hazardous substances (RoHS) DIRECTIVE

The supplier's responsibility is excluded in the event of any modification or intervention in the product carried out by the customer.

	Product Standards	Standards
Safety	EC/EN 62040-1	EC/EN 60950-1
Electromagnetic Compatibility (EMC)	IEC/EN 62040-2 (C1)	IEC/EN 61000-4-2 IEC/EN 61000-4-3 IEC/EN 61000-4-4 IEC/EN 61000-4-5 IEC/EN 61000-4-6 IEC/EN 61000-4-8 IEC/EN 61000-2-2
RoHS	EN50581:2012	EN50581:2012

Table 1.1 Standards

2

General Description

2.1 Introduction

Congratulations on your purchase of the PowerWave PW3000/TP UPS.

Continuous power availability is essential in today's dynamic IT and process-related work environments. It is equally important that any installed power protection system is sufficiently resilient and adaptable to handle any changes brought about by the introduction of new server technologies, migration and centralization.

Such demands are well met by the PowerWave PW3000/TP UPS system which provides the foundation for continuous power availability of network-critical infrastructures both in enterprise data centres, where business continuity has paramount importance, and in process control environments where manufacturing continuity is essential.

Reliability and quality standards

By using a unique modular construction and incorporating the latest technological developments in power engineering, the PowerWave PW3000/TP represents a completely new generation of transformerless 3 phase UPS-System. Its advanced double conversion VFI (Voltage and Frequency Independent) topology responds fully to both the highest availability and environmentally friendly requirements compliant with IEC 62040-3 (VFI-SS-111) standards. A full UPS Specification is contained in Chapter 8 of this manual.

Uninterruptible Power Supplies Ltd specialises in the installation and maintenance of Uninterruptible Power Systems; and this powerful UPS is just one example of our wide range of state-of-the-art power protection devices that will provide your critical equipment with a steady and reliable power supply for many years.

Key features

In addition to its high reliability, upgrade ability, low operating costs and excellent electrical performance the key features of the PowerWave PW3000/TP include the following:

- Energy savings thanks to 93% AC-AC efficiency, 97% efficiency in ECO mode
- Low harmonic distortion (< 5% THDi) and active power factor correction (0.99 input PF) eliminates interference from other network equipment
- Paralleling and redundancy capability – up to 4 units can be connected in parallel to increase the overall system capacity and availability.
- Integrated automatic and manual bypass simplifies maintenance and reduces need for external switchgear.
- Frequency converter operation to convert 50 to/from 60 Hz
- Compact solution that can achieve 5-16min runtime with internal batteries
- Supports different wiring schemes: three-phase and single-phase input as well as single and dual input feed
- Matching external battery cabinet available for extended autonomy time

2: General Description

2.2 PowerWave PW3000/TP Model range

The PowerWave PW3000/TP range comprises 10kVA and 20kVA UPS models, contained in identically sized cabinets. Depending on the required autonomy time, the UPS batteries can be housed within the UPS cabinet (with various battery arrangements) or housed in a purpose designed and matching battery cabinet which can be installed adjacent to the UPS cabinet to form an aesthetically pleasing suit. Although the UPS produces a single-phase a.c. output, it can be connected to either a single or three phase input supply. It can also be used in a frequency changer role with 50Hz/60Hz input/output or vice versa.

Up to four UPS cabinets can be connected in parallel to increase the overall system output capability or introduce a level of module redundancy to further enhance the system availability



Key Point: In a parallel system ALL the connected modules must be of the same output rating – i.e. it is not permissible to combine 10kVA and 20kVA cabinets in a parallel system.

		10kVA	20kVA
Maximum power connection	kW/kVA	9.0/10	18/10
UPS Cabinet Dimensions (WxHxD)	mm	350 x 890 x 712	350 x 890 x 712
UPS Cabinet Weight excluding batteries	kg	56	66
UPS Cabinet Weight including batteries (5 mins /16 mins)	kg	117 / 177	187 / NA

Table 2.2 PowerWave PW3000/TP Cabinet specifications

2.3 Functional description of operation

This section describes:

- The internal operation of an individual UPS power module at block-diagram level
- The various operational modes of an individual UPS power module
- UPS system operational modes – ‘On-line’ versus ‘Off-line’ system operation
- Multi-module system operation and paralleling considerations

2.3.1 PowerWave PW3000/TP Module block diagram

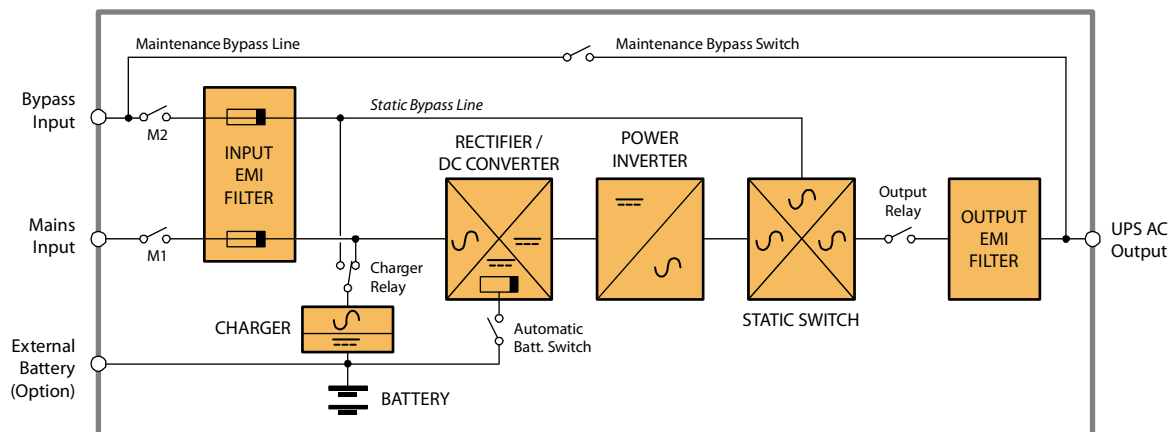

Figure 2.1 PowerWave PW3000/TP UPS block diagram

UPS Mains input supply

The UPS mains input can be connected to a 3ph+N or 1ph+N supply. It is connected to the Rectifier/DC Converter via the ‘Mains 1’ (M1) input breaker and a fuse on the Input RFI Filter. If a single phase input supply is used, the three input line terminals are linked together and the contacts of the input breaker (M1) are effectively paralleled.

UPS Bypass input supply

A single phase bypass supply is connected directly to the Maintenance Bypass Switch and also to the bypass side of the static switch, via the 'Mains 2' (M2) breaker and a fuse on the Input EMI Filter. In a standard installation the bypass input terminals are usually linked to the mains input supply L1 terminal, so only one mains supply feed is required. This is often referred to as a 'Single Feed' input configuration, as opposed to a 'Dual Feed' input where a separate bypass supply is used. (See paragraph 3.7 for details concerning 'Single Feed' & 'Dual Feed' supply configurations.)

Battery charger

The battery charger can be powered from either the Mains Input or Bypass Input supply, and charges the internal (or optional external) batteries when either of these supplies is present. It's power source is selected by a relay which automatically switches over to the Bypass Input supply when the Mains Input is not available. The charger is rated at 2A but can be increased to 4A if required, depending on battery topology.

Rectifier / DC Converter

The Rectifier / DC Converter produces a controlled DC voltage for the Inverter input. This can be sourced either from the UPS Mains input supply (AC) or from the battery (DC). An automatic changeover switch ensures that the two sources are never connected to the Rectifier /DC Converter simultaneously, with the UPS Mains input always being accepted as the preferred source provided it remains within specified limits.

Power Inverter

A single phase Inverter converts its DC input from the Rectifier / DC Converter into the required UPS output AC supply. The output voltage is tightly regulated using advanced PWM techniques and the output frequency is similarly controlled. Usually, the inverter operates at the same frequency as the UPS input/bypass supply; however, the UPS can be operated in a frequency-changing mode whereby the input and output frequencies are different – e.g. 50Hz/60Hz input/output. Note that when used as a frequency-changer, the UPS bypass circuit is automatically inhibited.

Static switch

The static switch block contains two static switches connected across a load transfer relay, one is connected to the bypass supply and the other to the inverter output. When the load is transferred between the bypass and inverter the appropriate static switch turns on for a brief period to maintain the load supply while the load transfer relay operates. The microprocessor system automatically controls the load transfer between inverter/bypass sources as dictated by local conditions (e.g. overload) and provides a means of performing a manual load transfer.

Output relay

The output relay is used to connect/disconnect the UPS output in a parallel module system, and enables the UPS to be quickly isolated from the system in the event of a UPS fault.

Maintenance bypass switch

The Maintenance Bypass Switch connects the UPS AC Output terminals directly to the Bypass Input and provides a means of temporarily supplying the load from the raw mains while the UPS is otherwise shut-down for maintenance repair. It operates in a make-before-break fashion to ensure the load is supported during the transfer.

In order to protect the UPS inverter, the load must be transferred to the static bypass supply before the Maintenance Bypass Switch is closed – this is performed automatically when the Maintenance Bypass Switch access cover is removed.

When the load is connected via the maintenance bypass the UPS can be shut down safely for repair, with the only remaining live areas within the UPS being the input/output power connections and isolators.

UPS AC Output (load) supply

Figure 2.1 shows that the UPS output (Load Supply) can be provided through one of three power paths depending on the UPS operating mode – the criteria for operating under each of these UPS modes is described in 2.3.2:

- From the inverter, via the inverter-side static switch and output relay
- From the static bypass line via the bypass-side static switch and output relay
- From the maintenance bypass line via the maintenance bypass switch

2: General Description

2.3.2 UPS Module operating modes

All the diagrams in this section depict a single UPS cabinet. Where two or more cabinets are operating as a parallel system they will always adopt the same operating mode due to their parallel control logic signals.

Load on Inverter

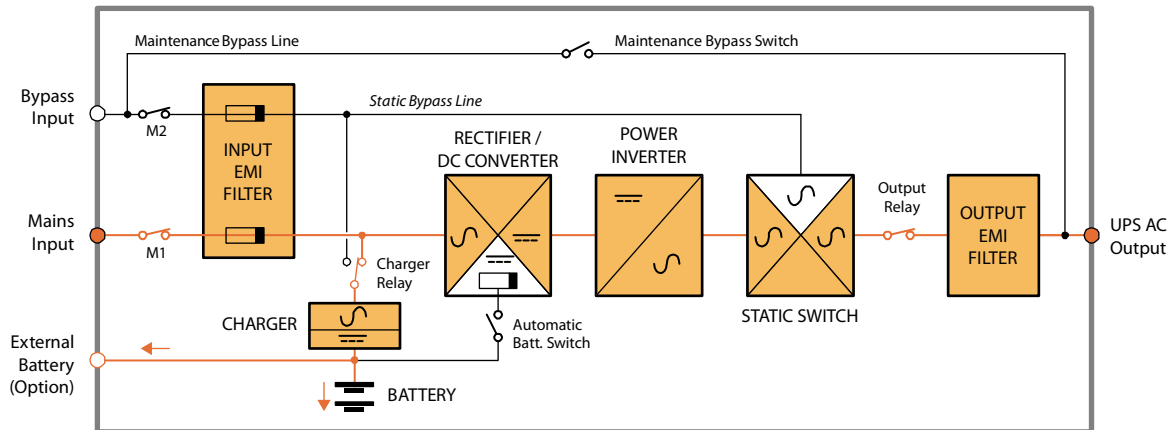

Figure 2.2 Load on inverter

This is the normal operating mode and the only one that provides the load with continuously processed and backed-up power. In this mode, the mains supply is converted to controlled DC by the Rectifier/DC Converter then converted back to the rated AC output voltage by the Inverter and connected to the load via the inverter side of the static switch.

The inverter output frequency is synchronised to the bypass supply provided it remains within preset limits; and if these limits are exceeded, or if the bypass supply fails altogether, the inverter frequency control reverts to a free-running oscillator that will produce a constant 50Hz (or 60Hz) UPS output.

Load on Battery

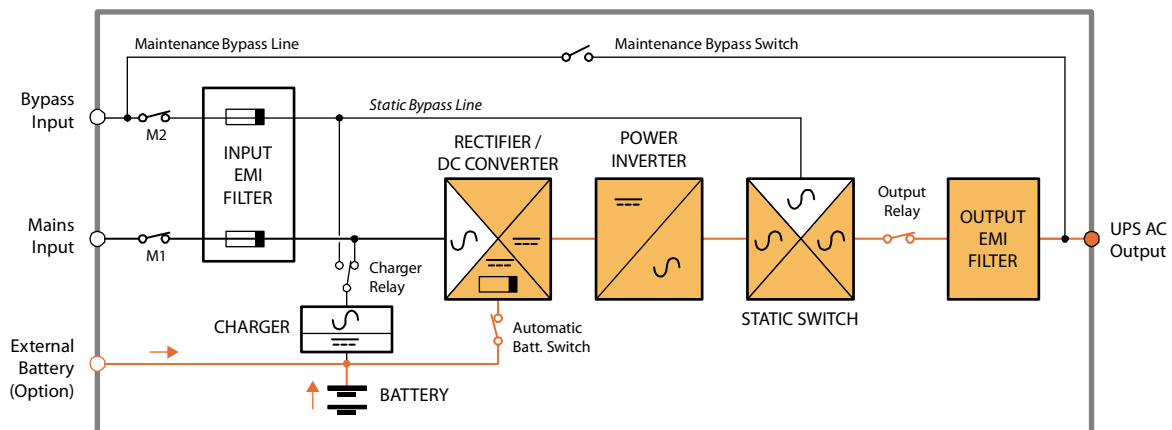

Figure 2.3 Load on battery

If the mains supply fails, the rectifier will shut down and the battery will provide an alternative DC power source for the inverter via the DC converter. The yellow 'Battery' led will illuminate on the control panel to indicate that it is on load and a 'ON BATTERY' status indication will be displayed on the LCD, accompanied by an audible alarm.

In the case of a dual feed input – if the bypass supply remains live the inverter frequency will remain synchronised to the bypass provided it stays within its preset limits.

In the case of a single feed input – the bypass supply will fail at the same time as the mains supply and under these circumstances the inverter frequency will revert to a free-running oscillator that will produce a constant 50/60Hz output.

Some installations include a standby generator which is designed to start-up automatically and provide an alternative UPS power input within a short period following a mains failure. Once the UPS input power is restored from the standby generator, the rectifier and charger will resume normal operation.

Battery discharge operation

As the battery discharges, various options are available to automate the load shut-down process, as described in Chapter 8 of this manual.

A SHUTDOWN IMMINENT alarm indicates when the battery is almost exhausted, with approximately 3 minutes autonomy time remaining, and if a data protection application is installed it will begin its automatic PC shut down routine at this point. When the battery reaches its fully discharged voltage the UPS will attempt to transfer the load to the bypass supply but if the bypass supply is unavailable then the UPS will totally shut down.

Load on Bypass

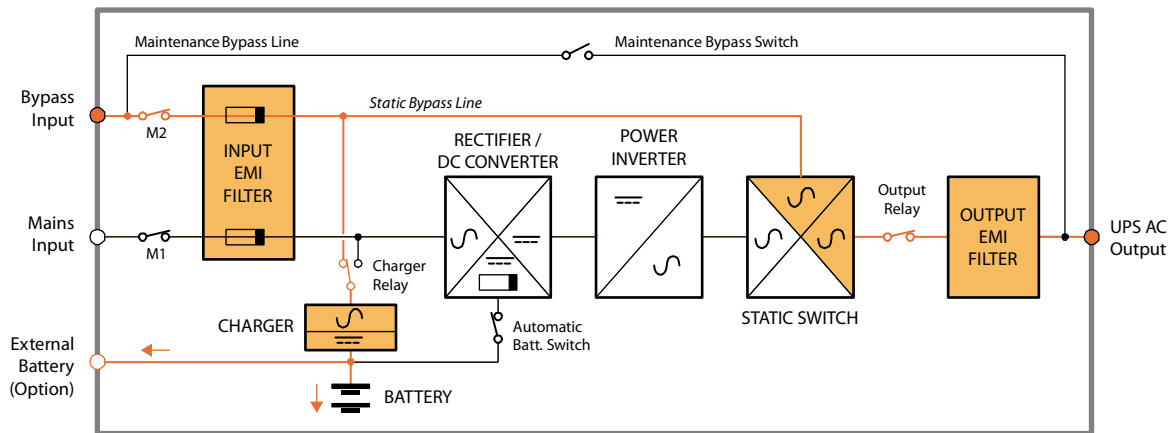

Figure 2.4 Load on bypass

In the ‘load on bypass’ mode the UPS AC Output is connected to the unprocessed static bypass line via the bypass side of the static switch.

During normal operation the load will be transferred from the inverter to the static bypass line in the event of an inverter fault, output overload, or loss of system redundancy due to a failed module in a parallel module system. Load transfer can also be initiated manually via the UPS control panel.

Depending on the reason for the load being transferred to bypass (i.e. manually transferred or transferred due to a fault), The Rectifier/DC Converter and Inverter power blocks might turn off or remain running.

Load on Maintenance Bypass

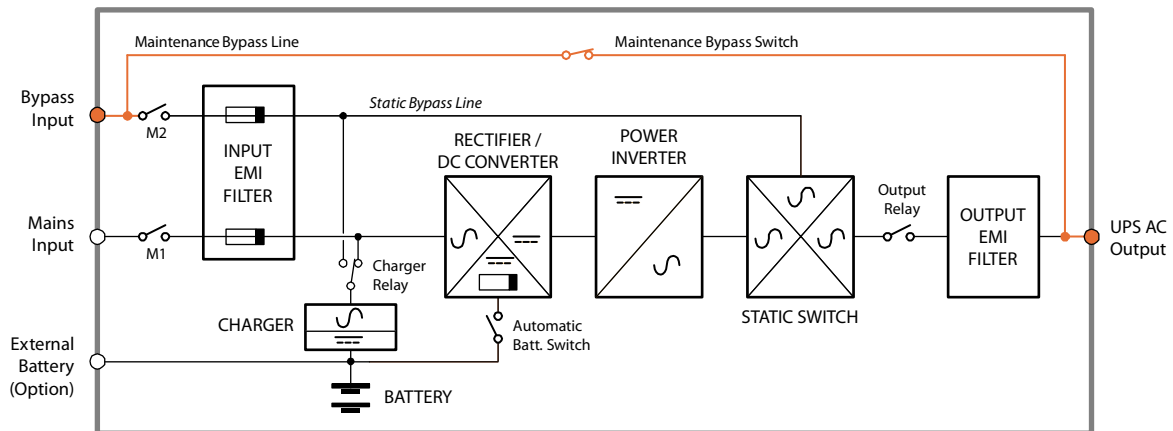

Figure 2.5 Load on maintenance bypass

2: General Description

In this mode of operation the manually closed maintenance bypass switch connects the UPS AC Output directly to the unprocessed bypass supply. This is used to keep the load supplied, albeit without any power protection, whilst allowing the remainder of the UPS system to be shut down for service repair.

To prevent possible inverter damage, it is important that the inverter output and maintenance bypass lines are never connected in parallel. Therefore when transferring from the 'load on inverter' mode to the 'load on maintenance bypass' mode it is important that the load is first transferred to the static bypass ('load on bypass' mode) before the maintenance bypass switch is closed.



WARNING: always follow the operating instructions in this manual when starting or shutting down the UPS.

2.3.3 UPS System operating modes

The previous section described the internal operating modes of an individual UPS module: but UPS systems are also categorised according to the way in which they are used at a 'system' level; and are typically described as being an 'on-line', 'off-line' or 'line interactive' UPS system. The PowerWave PW3000/TP can be operated in all three categories.

On-line operation

When used as an 'on-line' UPS system, the PowerWave PW3000/TP UPS normally operate in its 'load on inverter' mode and will automatically change over to 'load on bypass' in the event of an inverter fault or overload. The bypass-side static switch will transfer the load to the bypass supply without interruption (transfer time = 0).

If the transfer is due to an overload the UPS will attempt to switch back to the 'load on inverter' mode if the overload clears while on bypass, and the inverter returns to normal operation. An 'on-line' system therefore provides the highest degree of load protection and is always recommended if the critical load will not tolerate even a very brief supply interruption.

If the load fails to successfully re-transfer to inverter three times within ten minutes, further transfer attempts will be locked out – the load will remain on bypass and a warning message will appear on the LCD screen.

Off-line and line interactive operation (HE / ECO mode)

When the PowerWave PW3000/TP is used as an 'off-line' or 'line-interactive' UPS system it normally operates in the 'load on bypass' mode with the load being supplied through the static bypass supply; however the rectifier/DC Converter and battery charger are still powered up to maintain battery charging, and the inverter section is enabled and on standby.

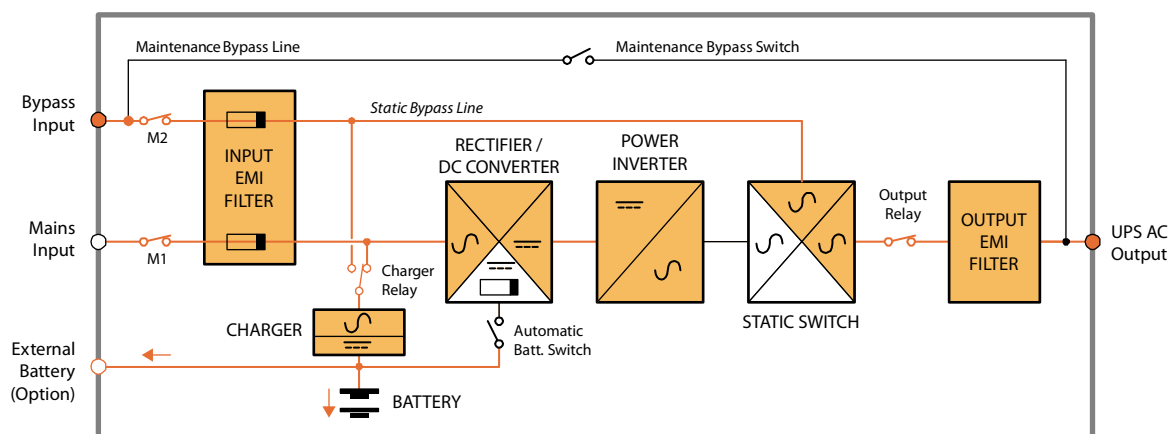

Figure 2.6 ECO (Off-line) mode of operation

If the bypass input supply fails, the static switch will automatically transfer the load to the inverter within 3-5ms; and if the rectifier's mains input supply is missing when the transfer takes place the inverter will operate immediately from battery power ('load on battery' mode). When the bypass supply returns to normal, the load automatically transfers back to the static bypass line ('load on bypass' mode) and the inverter returns to its standby operation.

An 'off line' system is a slightly more efficient than an 'on-line' system due to the reduced rectifier/inverter losses during normal operation, and for this reason it is sometimes referred to as the 'High Efficiency (HE)' or 'Economy ECO' mode.



WARNING: This mode is recommended only if the connected load equipment can tolerate a power interruption of up to 3 to 5 ms during the transfer period.
The 'on-line' mode must always be used for critical load protection.

2.3.4 Optional operating mode settings

The above descriptions refer to the UPS operation in what can be considered to be a 'standard' installation. However, the operation can be modified to suit local conditions, or particular load supply requirements, by adjusting the selected values in the LCD SETTINGS sub-menu, as shown in Figure 2.17.

Note: These settings are password-protected and can only be changed by authorised service personnel.

Auto Restart

If the input mains supply fails, and no bypass mains supply is available, the UPS will operate on-battery and shut down when the battery reaches its end of discharge voltage, or immediately if the battery is disconnected. The Auto restart setting determines whether or not the UPS restarts automatically following the return of the input mains.

The default value for Auto restart is [Enabled]. This means that if the UPS shuts down following a mains failure it will restart automatically and return the load to the inverter when the mains supply returns. If Auto restart is [Disabled] the UPS will have to be restarted manually.

Note: If the UPS shuts down due to an overload, an automatic restart can be [Enabled] or [Disabled] by setting the separate Automatic overload restart parameter.

Auto Bypass

In a 'standard' installation the load will be transferred to the bypass supply (if available) if the inverter shuts down due to an overload, inverter fault or a fully discharged battery when operating on battery power. However, in areas where the mains supply is unstable the automatic transfer to bypass function can be inhibited by setting the Auto bypass to [Disabled].

Note: If Auto bypass is [Disabled] the UPS will shut down (and drop the load) when it is operating on battery power and the battery reaches its end of discharge voltage.

Short Circuit Clearance

This parameter determines how the UPS reacts to a short circuit on its output.

If a short circuit is detected the inverter will limit its output current to 100% by reducing its output voltage – once the short circuit is cleared the output current will fall below 100% and the output voltage will return to normal.

By default the Short circuit clearance is set to [Disabled], and in this case the inverter will continue to supply 100% load for 100 ms. After this time the UPS is shut down if its output voltage is still <50%

If Short circuit clearance is [Enabled], the inverter short circuit clearance time is extended to 4 seconds.

2.3.5 Multi-module parallel system operation

To expand the overall UPS system rating, up to four PowerWave PW3000/TP UPS cabinets can be connected together to operate as a parallel UPS system. This is achieved by connecting each cabinet's output power terminals in parallel at an external load distribution panel and linking together the parallel control bus in each cabinet to effectively provide a common parallel control bus. The parallel control bus cable is connected to a socket located near the top rear of the cabinet which is covered by a blanking plate when not used (item 12 in Figure 2.7).

It is essential that any installed UPS power protection system can be expanded to meet a growing load demand without compromising the existing load supply. This situation is easily managed by a PowerWave PW3000/TP system which makes it possible to add a further cabinet to an existing UPS system without disrupting the load supply.

Note: Every PowerWave PW3000/TP cabinet is supplied with all the features required for parallel operation to eliminate any need for time-consuming or expensive upgrading on site.

2: General Description

'Capacity' versus 'redundant module' system

The paralleled UPS modules can be operated as either a *capacity* or *redundant* module system. The difference between the two is that a 'capacity' system is rated such that ALL the UPS modules are required to furnish the specified full load power, whereas a 'redundant-module' system is designed with one (or more) UPS module over and above that required to supply the full load.

In a redundant-module system it is therefore possible to lose one (or more) UPS module without disrupting the load, whereas this is not the case in a capacity system, where the loss of one UPS module would automatically transfer the load to the bypass supply.

Parallel control bus

All the UPS modules within are connected to a parallel control bus which carries various inter-module control signals used for frequency synchronisation, load sharing etc. By using sensing signals passed over the parallel control bus, each module can electronically compare its own frequency and output current with that of its neighbouring module and carry out fine adjustments to achieve balanced conditions.

2.4 PowerWave PW3000/TP User controls

The following illustrations show the location of the PowerWave PW3000/TP power switches and fused isolators that are used when operating the equipment. The control panel is described in paragraph 2.5 and the various optional input/output connecting facilities are described in Chapter 7.

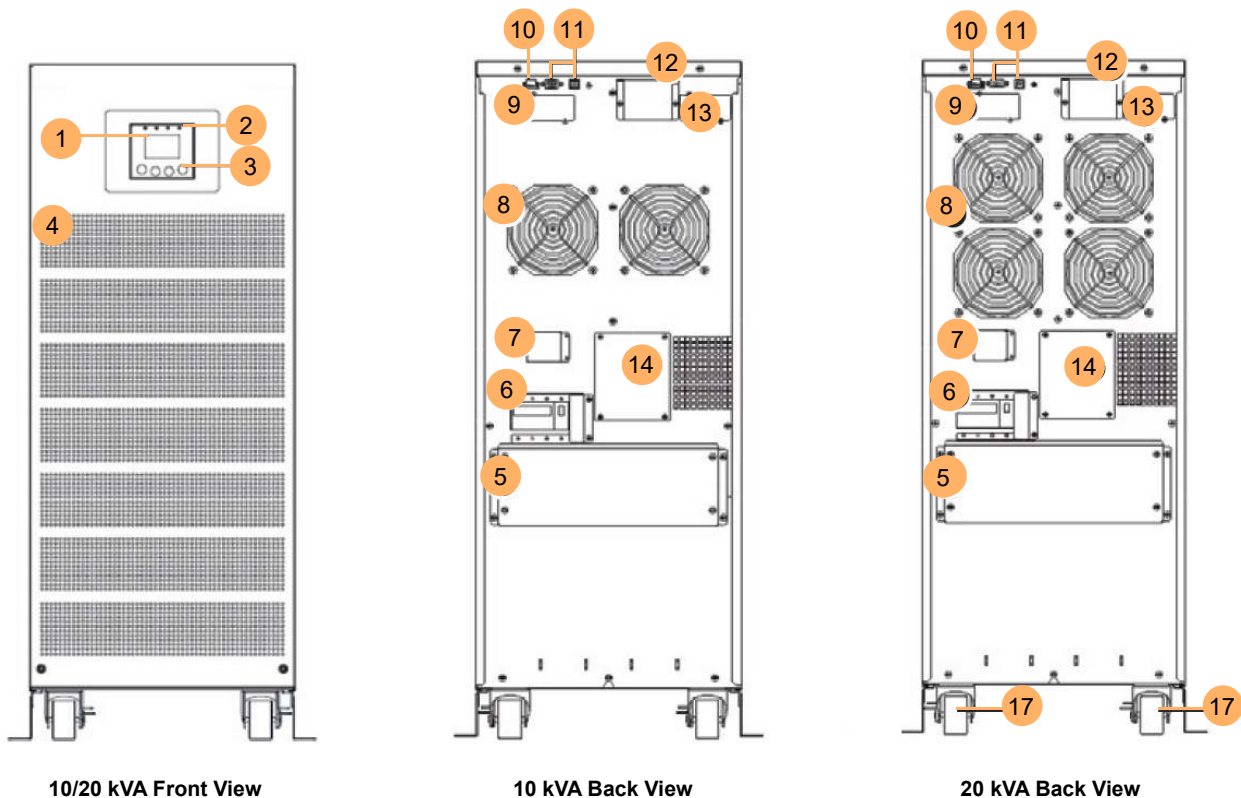

Figure 2.7 PowerWave PW3000/TP Controls identification

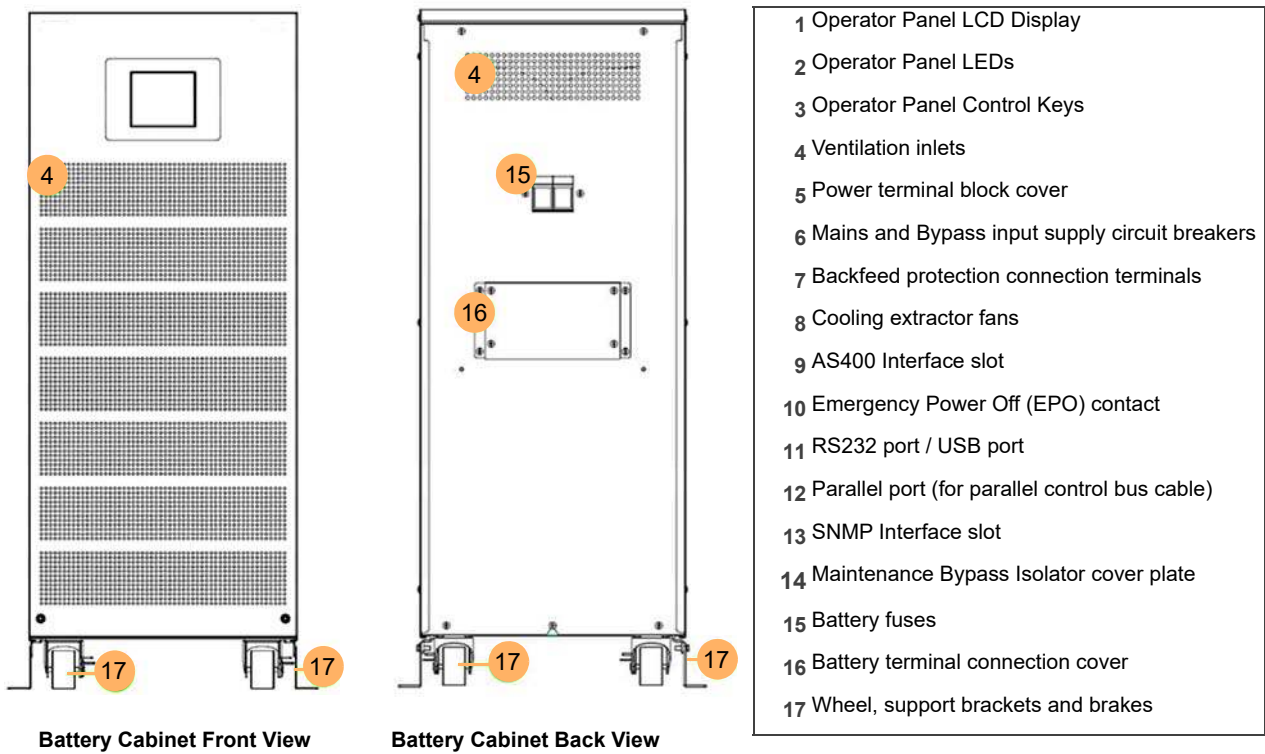

Figure 2.8 PW3000/TP Matching battery cabinet

2: General Description

2.5 UPS Control panel

The UPS Control panel contains four status LED indicators, an LCD display and a row of selection keys which include an ON/OFF key and three navigation keys. The navigation keys are used in conjunction with various monitoring and configuration menus.

2.5.1 Status LED indicators

The four LEDs located along the top of the UPS Control panel indicate the UPS operating status and may FLASH or remain constantly OFF or ON. Under some circumstances all five LEDs will illuminate in turn in a 'rotating' sequence.

The following table illustrates the LED states for various operating conditions – an 'X' indicates that the state is undefined and depends on the failure or warning mode.

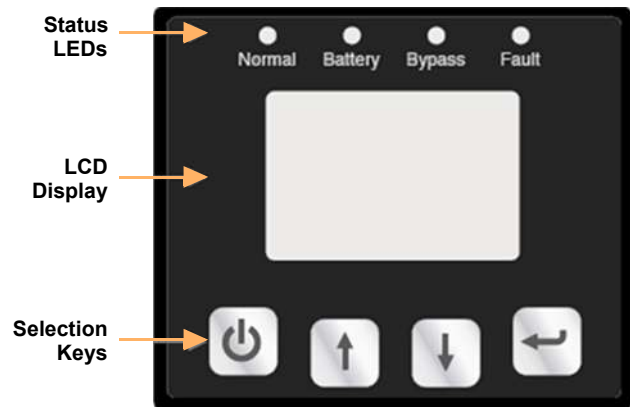

Figure 2.9 UPS Control Panel

UPS STATUS	NORMAL (green)	BATTERY (amber)	BYPASS (amber)	FAULT (red)
Bypass Mode / with no output power			FLASH	X
Bypass Supply abnormal			FLASH	
Bypass Mode / with output power			ON	X
UPS Turning ON	SEQUENCE	SEQUENCE	SEQUENCE	SEQUENCE
On-line mode	ON			X
On-battery mode	ON	ON		X
ECO mode (HE Mode)	ON		ON	X
Battery Test mode	SEQUENCE	SEQUENCE	SEQUENCE	SEQUENCE
Fault mode			X	ON
Warning	X	X	X	FLASH

Table 2.3 Status LED interpretation

2.5.2 LCD Display

A complete overview of the UPS operating status including the input, output, battery and load parameters is provided by the LCD display.

Under normal operating conditions the display shows white text on a blue back-light but under fault conditions this changes to dark text on an orange back-light, accompanied by an audible warning, as shown in the adjacent table.

UPS Condition	Buzzer Status
Active failure	Continuous
Active warning	Beep once per second
UPS on Battery	Beep every four seconds
Low Battery	Beep every second
On Bypass	Beep every two minutes
Overload	Beep twice per second

Table 2.4 Audible warnings

Default Screen

During start up the LCD Display shows a 'Welcome' logo screen for around 5 seconds while the UPS initialises then changes to the 'default status' screen shown in Figure 2.10. The 'default status' screen is shown automatically during normal operation if the control panel keys are not operated for 15 minutes.

The default screen provides the following information:

- UPS input parameters – including an indication of the mains/bypass input voltage, and frequency
- UPS status – a symbolic indication of the UPS operating mode and fault/abnormal conditions. A list of status symbols is described in Table 2.5.
- Battery status – including the battery voltage and a graphical indication of the available battery charge
- Load status – graphical and numerical percentage indication of the connected UPS load
- UPS output – including an indication of output voltage, frequency and load power (W)

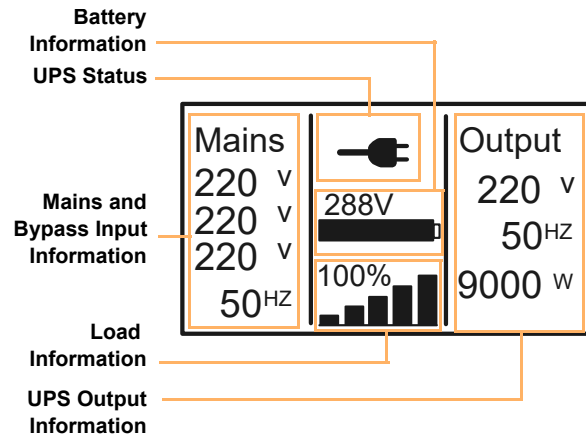

Default Screen status symbols

Figure 2.10 LCD Panel Default Screen

Symbol	Status	Description
	ON-LINE	UPS is operating with the load supplied by the inverter.
	ON BATTERY	UPS is operating from battery power, usually due to a mains failure.
	ON BYPASS	UPS is operating with the load supplied from the bypass mains power. <i>Note: if there is a bypass supply failure while the UPS is on bypass, it will not transfer to ON LINE or ON-BATTERY mode unless it is operating in the ECO-mode – also known as High Efficiency (HE) mode.</i>
	ECO Mode (HE mode)	UPS is operating with the load supplied from the bypass mains power. In case of bypass mains failure, the UPS transfers to ON LINE mode or ON BATTERY mode and the load is supplied continuously. ECO-mode can be enabled/disabled through the control panel <i>Settings</i> menu or the UPS monitoring/control software.
	CONVERTER mode	UPS is set to operate with a different input and output frequency – either 50Hz-60Hz or 60Hz-50Hz. In case of input mains power failure, the bypass is inhibited and UPS transfers to ON BATTERY mode.
	WARNING	UPS is operating in the presence of an abnormal condition that does not call for the UPS to be shut down. See the Troubleshooting chapter for details.
	FAULT	The UPS has experienced a fault condition. It may disconnect the load or transfer the load to bypass depending on the type of failure. In all cases, there will be a constant alarm and the LCD back-light will become red. See the Troubleshooting chapter for details.
	OVERLOAD	UPS is overloaded. The load should be reduced to <90% of the UPS rated capacity in order to stop the alarm.
	BATTERY TEST	UPS is performing a battery test.
	BATTERY DISCONNECTED	UPS battery is disconnected or defective – accompanied by an alarm.

Table 2.5 Default Screen status symbols

2: General Description

2.5.3 UPS Control panel operator keys





Operator KEY	Function	Operation
	Power ON / OFF EXIT MENU	Press for 1s to turn ON the UPS. Press for >3s to turn OFF the UPS or change the UPS operating mode between 'on-line' and 'on-bypass'. Press for <1s to exit a menu and return to the default status screen.
	SCROLL UP	From the default status screen, press for >1s to access the Main Menu. Within a sub-menu press for <1s to scroll UP through the current menu options.
	SCROLL DOWN	From default status screen, press for <1s to access the Status sub-menu. Within a sub-menu press for <1s to scroll DOWN through the current menu options.
	SELECT / EDIT	This key is used when editing the value of a parameter in the setup/configuration menu screens. If pressed for less than one second it accepts the entered value and if pressed for more than one second it saves the setting and exits the screen.

Table 2.6 UPS Control panel operator keys

2.5.4 LCD Menu navigation

All the UPS control, monitoring and configuration functions are actioned through a series of menus displayed on the LCD and navigated using the control panel keys described in Table 2.6.

 **Key Point:** In the following description of the menu navigation system the keys will be described as ON/OFF, UP, DOWN and SELECT.

2.5.5 Main Menu

As shown in Figure 2.11, the main (top level) menu is accessed from the Default screen by pressing the UP key for greater than 1 second. It presents 6 options; Status, Event log, Measurements, Control, Identification and Settings which can be scrolled through using the UP/DOWN keys.

Each Main Menu option has an associated sub-menu which can be accessed by briefly pressing the SELECT key.

To return to the Default screen from any point in the menu tree, you must press the ON/OFF key for less than one second.

 **CAUTION:** When pressing the ON/OFF button to exit a menu take care not to hold the key pressed for longer than 3 seconds otherwise it will turn off the inverter and transfer the load to bypass.

Each of the Main Menu options is described below.

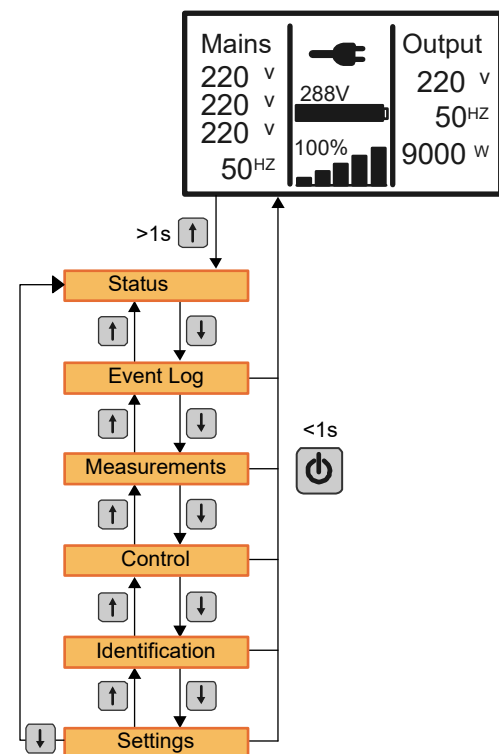

Figure 2.11 Menu navigation – Main Menu

2.5.6 Status sub-menu

The Status sub-menu is slightly different from the other sub-menus in that it can be accessed from two points: by selecting the Status option in the Main Menu or directly from the Default screen by briefly pressing the DOWN key. The Status Sub-menu shows the following:

Alarm

Displays a list of any active alarms (an alarm history can be obtained via the Event Log menu described below). Normal indication is <No alarm>

Battery

The Battery menu displays:

- Battery Volt: <XXX V>
- Battery charge regime (e.g. <floating>)
- Charge level: XX%

Status and running time

This menu displays:

- Status: <Line Mode / Combo 3/1>
Indicates 3ph input and 1ph output and UPS is on-line
- Para Num: <X>
Indicates the number of parallel modules
- Running Time: <XXXX:XX:XX:XX>
Indicates the time for which the module has been running (Days: Hrs: Mins: Secs)

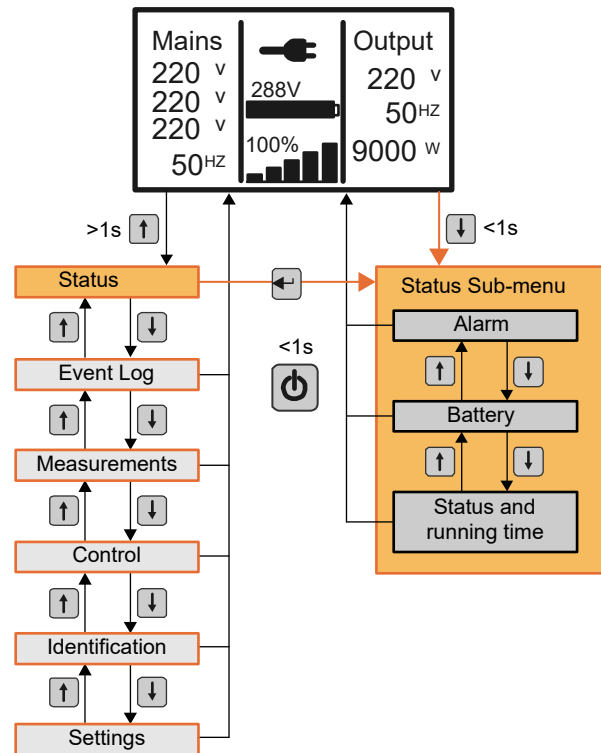

Figure 2.12 Menu navigation – Status Menu

2.5.7 Event Log sub-menu

The Event Log displays a date/time stamped list of the 50 most recent warning and fault events. Fault events are identified by a corresponding event code. To access the Event Log you must highlight the Event Log option in the Main Menu then press the SELECT key for longer than one second. This offers two further sub-menu options, from which you can choose to view either Warnings or Faults. Once accessed, using the SELECT key, you can scroll through the log entries using the UP/DOWN keys. To exit the Event Log screen you must press the ON/OFF key for less than one second.

2.5.8 Measurements sub-menu

The Measurements menu allows various UPS operating parameters to be observed, as shown in Figure 2.13.

To access the Measurements sub-menu you must highlight the Measurement option in the Main Menu then press the SELECT key for longer than one second. This opens the Measurements sub-menu screen which allows you to scroll through and observe the monitored parameters using the UP/DOWN keys.

To exit the Measurements sub-menu either press the UP key for longer than one second to return to the Main Menu or press the ON/OFF key for less than one second to return to the default screen.

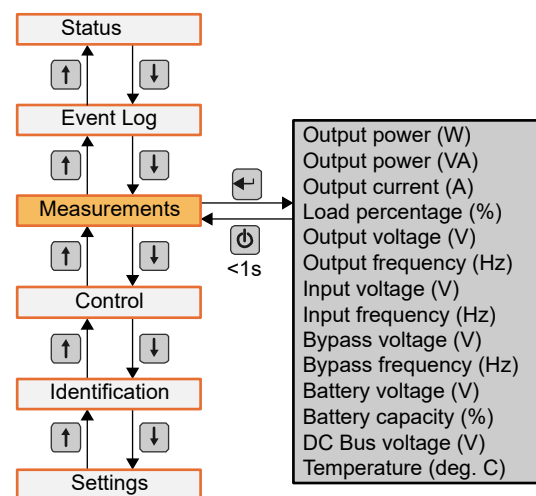

Figure 2.13 Menu navigation – Measurements

2: General Description

2.5.9 Control sub-menu

The Control menu allows various UPS operating features to be set.

There are two versions of the Control sub-menu depending on whether the UPS is operating as a single module installation or is part of a parallel module system. The single module version is shown in Figure 2.14 and the multi-module version in Figure 2.15.

To access the Control sub-menu you must highlight the Control option in the Main Menu then press the SELECT key for longer than one second. This opens the Control sub-menu which allows you to scroll through the monitored parameters using the UP/DOWN keys.

To modify a parameter you must:

1. Highlight the parameter in the Control sub-menu using the UP/DOWN keys.
2. Press the SELECT key for less than a second to access the available parameter values.
3. Highlight the wanted parameter value using the UP/DOWN keys then press the SELECT key for longer than one second to select the chosen value and return to the Control sub-menu.
4. To exit the Control sub-menu either press the UP key for longer than one second to return to the Main Menu or press the ON/OFF key for less than one second to return to the default screen.

Table 2.7, below, provides details of the available settings and the default values.

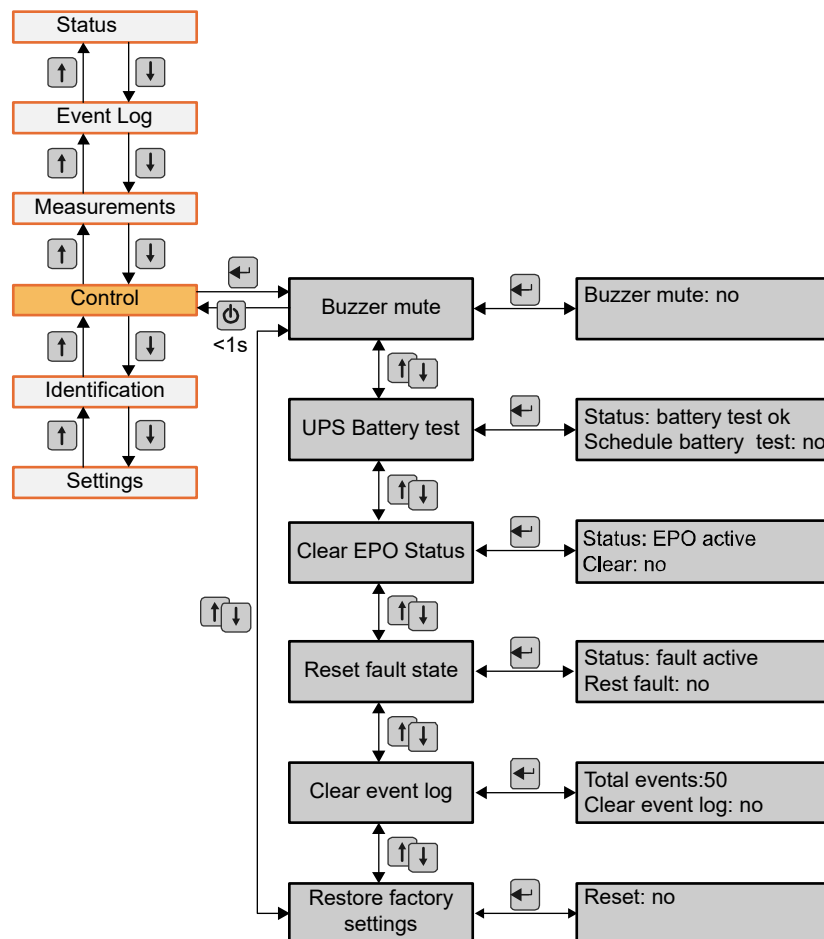

Figure 2.14 Menu Navigation – Control Menu (single module installation)

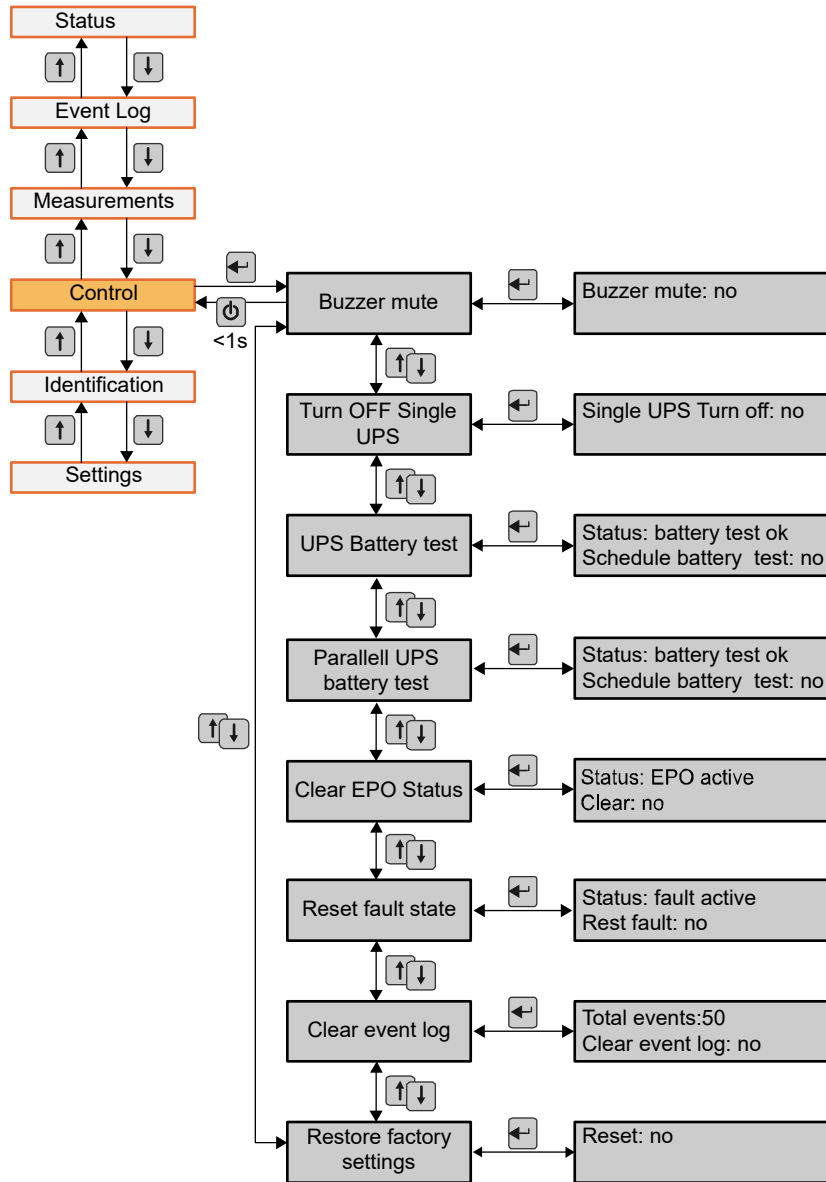

Figure 2.15 Menu Navigation – Control Menu (multi-module installation)

2: General Description

Control	Description	Values	Default
Buzzer Mute	Mute the audible warning alarm	No / Yes	No
*Turn OFF Single UPS	Allows an individual module to be turned off.	No /Yes	No
UPS Battery Test	Initiate test of the batteries of a single UPS	Schedule / No / Yes	No
*Parallel UPS battery test	Initiate test of the batteries of a group of UPS's	Seg1 and Seg2: On /Off	On / Off
Clear EPO status	Reset the UPS from emergency power off status	No / Yes	No
Reset Fault state	Reset warning and alarming status and buzzer	No / Yes	No
Clear Event Log	Reset all the events from the log file	No / Yes	No
Restore factory setting	Restores default settings, EPO polarity and locks the DC start-up	No / Yes	No

**Only relevant to multi-module installation*

Table 2.7 Control sub-menu options

2.5.10 Identification sub-menu

The Identification menu allows access to the UPS model data, serial number and firmware revision details, as shown in Figure 2.16. This information is often requested when seeking assistance from the manufacturer or service agent.

To access the Identification sub-menu you must highlight the Identification option in the Main Menu then press the SELECT key for longer than one second. This opens the Identification sub-menu screen which allows you to scroll through the stored data using the UP/DOWN keys.

To exit the Identification sub-menu either press the UP key for longer than one second to return to the Main Menu or press the ON/OFF key for less than one second to return to the default status screen.

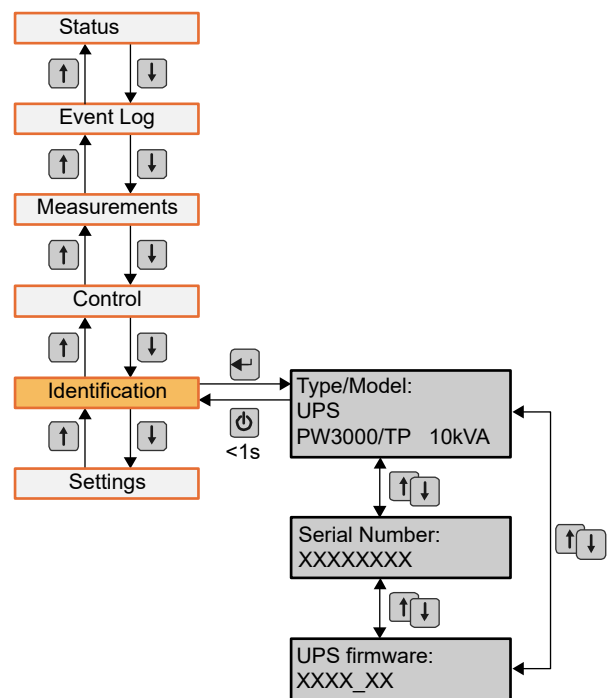

Figure 2.16 Menu Navigation – Identification

2.5.11 Settings sub-menu

The Settings menu allows various UPS operating parameters to be configured, as shown in Figure 2.17. Some settings can impact on the UPS performance, others can enable and disable functions within the UPS (see also paragraph 2.3.4).



WARNING: Inappropriately configured settings in this menu could result in reduced load protection or UPS performance. This menu set-up or modified only by a qualified service engineer.

To access the Settings sub-menu you must highlight the Settings option in the Main Menu then press the SELECT key for longer than one second. This opens the Settings sub-menu screen which allows you to scroll through the available options using the UP/DOWN keys.

To exit the Settings sub-menu either press the UP key for longer than one second to return to the Main Menu or press the ON/OFF key for less than one second to return to the default status screen.

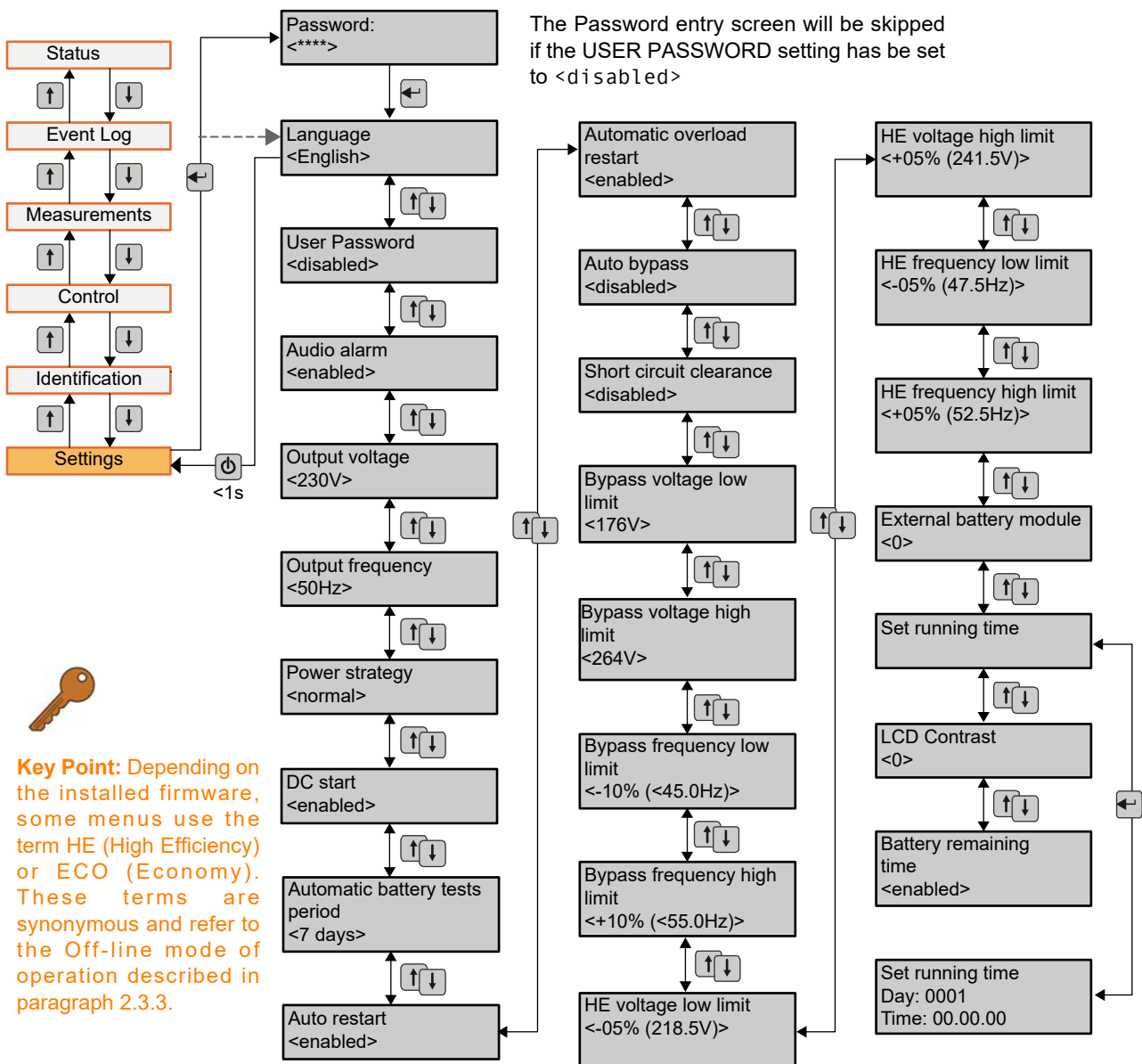

Figure 2.17 Menu Navigation – Settings

Important notes:

Password

Enter the password using the UP, DOWN and SELECT keys. If the User Password option is disabled the Password entry screen will be bypassed.

Frequency changer configuration

To configure the UPS as a frequency changer, ensure the inverter is turned OFF, select the Output frequency and set the Power strategy to <Converter>. Then totally shut down the UPS, and turn OFF the input mains power. The new configuration will activate when the UPS is next powered up.

External battery modules

A standard 10kVA module uses 1 battery string and a 20kVA module uses 2 strings. In each case the number entered in the 'External battery modules' menu should be set to <0> for a standard module and increased to equal the number of any optional external battery strings connected to the UPS.

Sub-menu Item	Description	Values	Default
User password	Protects against unapproved access	Enabled / Disabled	Disabled
Language	Select menu language	English / Chinese	English
Audio alarm	Enable / disable alarm sounds	Enabled / Disabled	Enabled
Output voltage	Define local output voltage	200/208/220/230/240V	230V
Output frequency	Define local output frequency (UPS detects the frequency in 'autosensing')	Autosensing / 50Hz / 60Hz	Autosensing
Power strategy*	Define the operating mode	Normal / ECO- mode / Frequency converter	Normal
DC start (Cold start)	Start the UPS from batteries, without mains power	Enabled / Disabled	Enabled
Automatic battery test period	Define the frequency of the battery tests	0-31 days	7 days
Auto restart	After power outage, the load restart automatically when mains power is recovered	Enabled / Disabled	Enabled
Automatic overload restart	The UPS automatically restarts if it shuts-down due to overload	Enabled / Disabled	Enabled
Auto bypass	The automatic bypass can be disabled if the bypass power supply is very unstable. UPS runs only 'on-line' or on-battery.	Enabled / Disabled	Disabled
Short circuit clearance	When enabled, short circuit can last for 4s before cutting off the output. If short circuit is removed during this time, the UPS will continue to run. When disabled, short circuit will only last for 100ms before the UPS output is cut off.	Enabled / Disabled	Disabled
Bypass voltage low limit	When the voltage in the bypass is below this limit, the UPS changes operating mode	176 ~ 215V	176V
Bypass voltage high limit	When the voltage in the bypass is above this limit, the UPS changes operating mode.	245 ~ 276V	264V
Bypass frequency low limit	When the frequency in the bypass is above this limit, the UPS changes operating mode.	40 ~ 49.5 Hz	45 Hz
Bypass frequency high limit	When the frequency in the bypass is above this limit, the UPS changes operating mode.	50.5 ~ 70 Hz	55 Hz
HE voltage low limit	When the voltage in the bypass is below this limit, the UPS changes operating mode.	1% ~ 10%	5%
HE voltage high limit	When the voltage in the bypass is above this limit, the UPS changes operating mode.	1% ~ 10%	5%
HE frequency low limit	When the frequency in the bypass is below this limit, the UPS changes operating mode.	1% ~ 10%	5%
HE frequency high limit	When the frequency in the bypass is above this limit, the UPS changes operating mode.	1% ~ 10%	5%
External Battery modules**	Define the number of external battery modules.	0 - 97	0
Set running time	Reset the UPS running time for tests purposes.	Day:hour:minute:second	Running time
LCD contrast	Change the contrast in the LCD display	-5 ~ +5	0
Battery remaining time	When enabled, the battery remaining time is displayed in the menu measurements	Enabled / Disabled	Disabled
* Read section 2.3 before using ECO-mode or converter function.			
** Enter the number of ADDITIONAL (external) battery strings. An incorrect entry might degrade the battery operation.			

Table 2.8 Settings sub-menu options

Example: How to change the rated output voltage

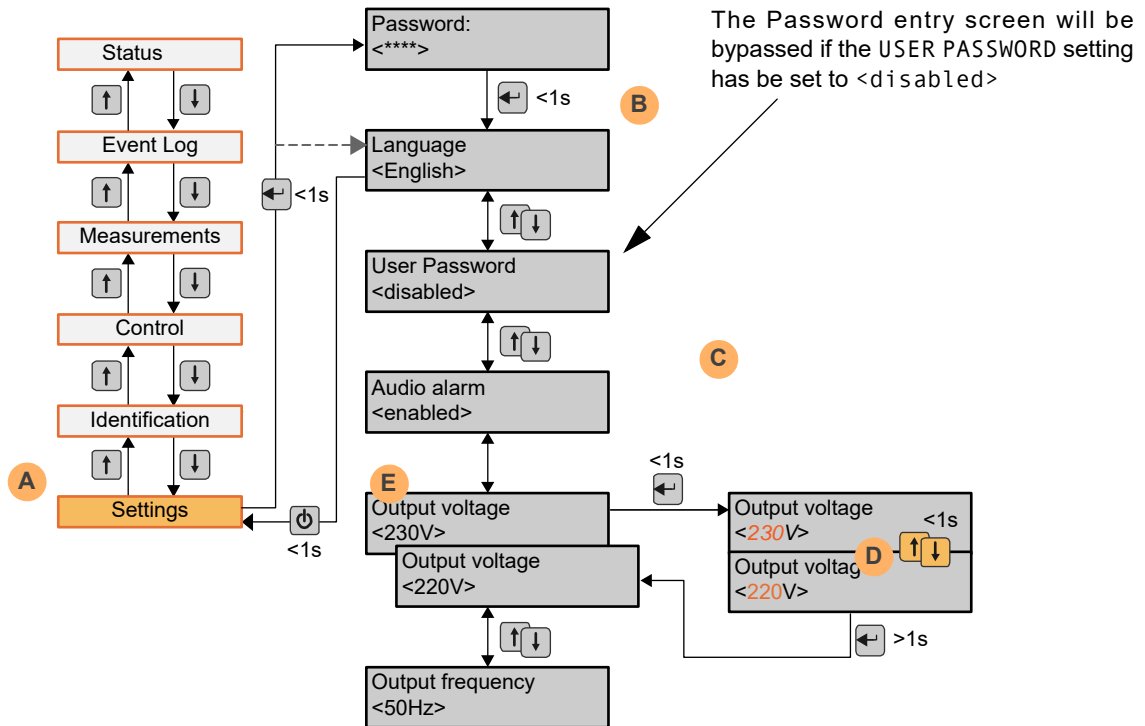

Settings Menu (changing output voltage)

This example shows the steps necessary to change the UPS output voltage from its default 230V setting to 220V.

1. Gain access to the Main Menu and, using the UP/DOWN keys, scroll through to 'Settings' (A).
2. Press the SELECT key (<1s) to access the Settings sub-menu, starting at 'Password' or 'Language' (B).
 Note that if the 'User Password' parameter has been set to <disabled> the 'Password' entry screen will be bypassed and you will be taken straight to the 'Language' option.
3. Enter the password if required then press the SELECT key.
4. Using the UP/DOWN keys, scroll through the Settings sub-menu to 'Output voltage,' then press the SELECT key (<1s) to access the 'Output voltage' change screen (C). Note that this may require password access if 'set'.
5. The values shown in the change screen will initially flash.
6. Change the indicated value using the UP/DOWN keys to select the required voltage (220V) then press the SELECT key for greater than one second to accept the change (D).
7. This will take you back to the Settings sub-menu where 220V will now be displayed in the Output voltage screen (E).
8. Continue scrolling through the Settings sub-menu using the UP/DOWN keys, and exit to the main Settings menu by pressing the UP key for greater than one second; or exit back to the Default Screen by briefly pressing the ON/OFF key.

2.6 Warranty

The PowerWave PW3000/TP UPS is supplied with a limited warranty that the UPS and its component parts are free from defects in materials and workmanship for a period of one year from the date of original commissioning or fifteen months from the date of original delivery, whichever is the sooner. This warranty is the only warranty given and no other warranty, express or implied, is provided.

This warranty is invalidated if the UPS is put into use without having been commissioned by a fully trained and authorised person. This warranty does not apply to any losses or damages caused by misuse, abuse, negligence, neglect, unauthorised repair or modification, incorrect installation, inappropriate environment, accident, act of God or inappropriate application.

If the UPS fails to conform to the above within the warranty period then Uninterruptible Power Supplies Ltd. will, at its sole option, repair or replace the UPS. All repaired or replaced parts will remain the property of Uninterruptible Power Supplies Ltd.

As a general policy, Uninterruptible Power Supplies Ltd does not recommend the use of any of its products in life support applications where failure or malfunction of the product can be reasonably expected to cause failure of the life support device or to significantly affect its safety or effectiveness. Uninterruptible Power Supplies Ltd does not recommend the use of any of its products in direct patient care. Uninterruptible Power Supplies Ltd will not knowingly sell its products for use in such applications unless it receives in writing assurances satisfactory to Uninterruptible Power Supplies Ltd that the risks of injury or damage have been minimized, the customer assumes all such risks and the liability of Uninterruptible Power Supplies Ltd is adequately protected under the circumstances

THE UPS SYSTEM MAY CONTAIN BATTERIES WHICH MUST BE RE-CHARGED FOR A MINIMUM OF 24 HOURS EVERY SIX MONTHS TO PREVENT DEEP-DISCHARGING. BATTERIES THAT HAVE BEEN, FOR WHATEVER REASON, DEEP-DISCHARGED ARE NOT COVERED BY THE WARRANTY.

2.7 Extended Warranty

The Standard Warranty may be enhanced by protecting the UPS with an Extended Warranty Agreement (maintenance contract). An Extended Warranty Agreement enhances the standard warranty by providing the following:-

- Regular preventative maintenance inspections.
- Guaranteed speed of response to operational problems.
- 24 hour telephone support.
- Fully comprehensive (excluding batteries) cover.
- Contact the Service Support Hotline on 0800 731 3269 for further details.

2.8 Additional Service/Maintenance Support

In addition to providing support for the PowerWave PW3000/TP, Uninterruptible Power Supplies Ltd can provide maintenance and support of a wide range of different UPS products.

If you are interested in an extended warranty for your PowerWave PW3000/TP, or any other UPS you may have, please complete the enquiry form shown opposite and return or FAX to:

Uninterruptible Power Supplies Ltd.
Woodgate
Bartley Wood Business Park
Hook
Hampshire
RG27 9XA

Tel: 01256 386700
0800 731 3269 (24 Hr.)

Fax: 01256 386701

Email: service@upspower.co.uk

3 Installation

3.1 Introduction

This chapter contains essential information concerning the unpacking, positioning, installing and cabling of the PowerWave PW3000/TP UPS.



WARNING: All cabling operations must be supervised by an authorised electrician or other suitably qualified person. All installation and operating procedures must be carried out in strict accordance with the instructions contained in this manual. Uninterruptible Power Supplies Ltd will take no responsibility for any personal injury or material damage caused by the incorrect installation, cabling or operation of this product.



WARNING: Once the UPS equipment is installed it must be commissioned by an engineer approved by Uninterruptible Power Supplies Ltd before it is powered-up. Uninterruptible Power Supplies Ltd will take no responsibility for any personal injury or material damage caused by the application of electrical power to this equipment before it has been fully commissioned.

3.2 Taking receipt of the UPS

The UPS cabinet and accessories are delivered on purpose designed pallets that are easy to off load and move using a forklift or suitable pallet jack.



CAUTION: Observe the following precautions when off-loading and moving the UPS:

- Always keep the packages in an upright position.
- Do not drop the equipment.
- Due to the fitted high-energy batteries and heavy weight, do not stack the pallets.

The packing container protects the UPS from mechanical and environmental damage during transit. This protection is further increased by wrapping the PowerWave PW3000/TP UPS with a plastic sheet.

Upon receiving the UPS you should carefully examine the packing container for any sign of physical damage.



CAUTION: Claims for visible shipping damage must be notified to the carrier immediately on receipt. Other shipping damage claims must be filed immediately when found and the carrier must be informed within a maximum of 7 days following receipt of the equipment. If shipping damage is discovered, store all packing materials for further investigation.

Ensure that the received UPS equipment corresponds to the description indicated in the delivery note. The package should contain:

1 x PowerWave PW3000/TP UPS	1 x User manual
1 x Parallel cable	1 x Parallel port cover plate
1 x power terminal jumper kit (6-hole)	2 x M5x12 HEX screw
4 x Cable glands	1 x Monitoring Software CD

3: Installation

3.2.1 Site transportation

Please observe the following precautions when you transport the UPS equipment between its off loading site and the intended installation (or storage) location.



CAUTION: Potential dangers:

- If the UPS/battery cabinet is tilted by more than 10° it could cause internal damage. If tilting occurs, do not connect the UPS to the mains electrical supply.
- The weight of the UPS/battery cabinet can cause serious personal injury and/or structural damage to the surrounding area if dropped in transit. Always take extreme care when moving the equipment.



CAUTION: Storage:

- The UPS should be stored in the original packing and shipping carton.
- The recommended storing temperature for the UPS is between +5°C and +40°C (+35°C for batteries).
- The UPS and the batteries must be protected from high humidity, which should not exceed 95% RH (non-condensing).

3.3 Unpacking

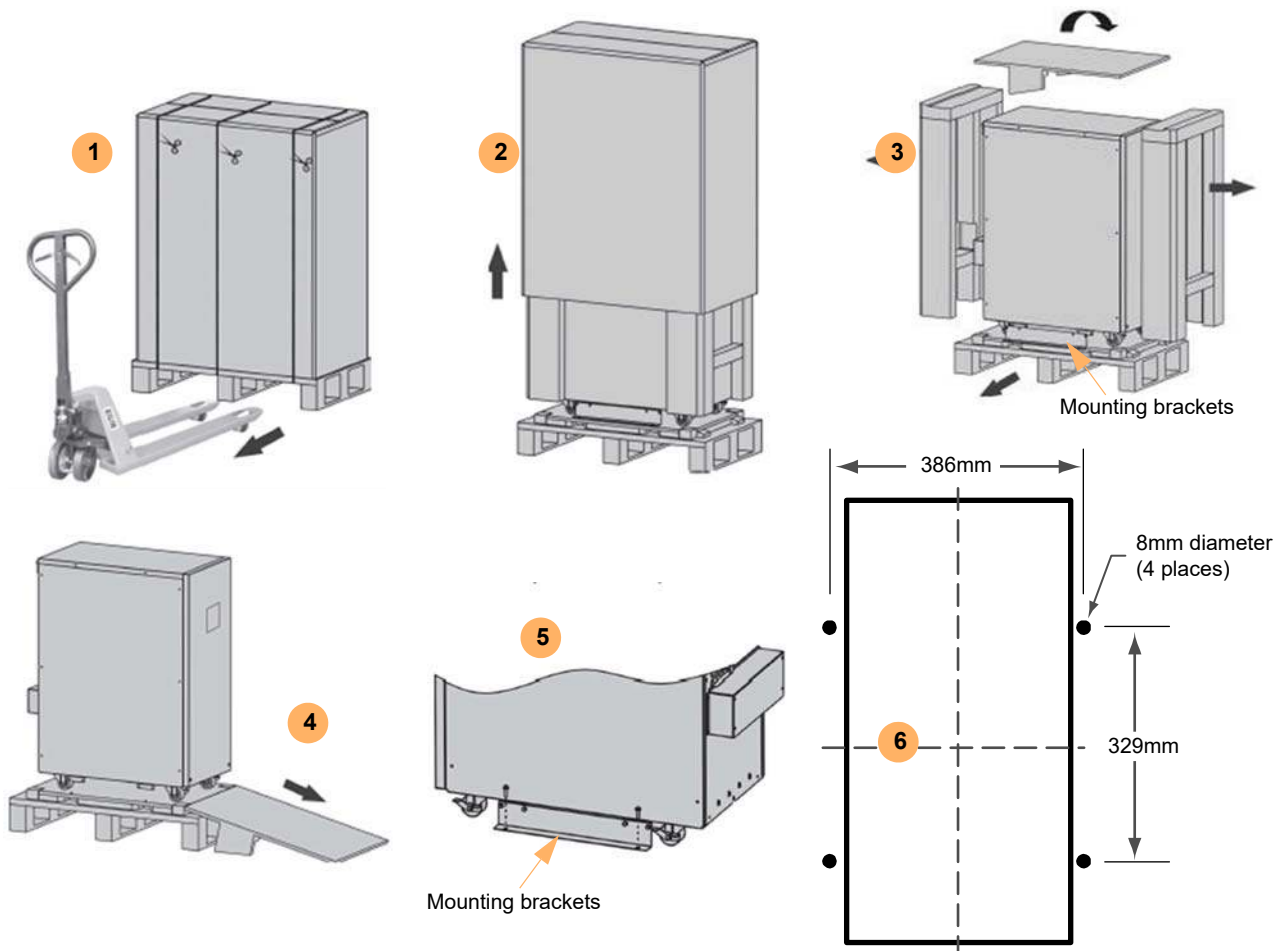

Figure 3.1 Unpacking and positioning the PowerWave PW3000/TP

1. Using a forklift, move the unit to the location where it is to be installed.

Note: The UPS has wheels to make final positioning easy after it has been unpacked, but these are not suitable for moving the unit over long distances.

2. Cut the wrappers and remove the packing carton by pulling it upwards.
3. Remove the protection packaging from the sides and top of the unit then remove the side mounting brackets securing the unit to the pallet. Retain the packaging materials for possible future shipment of the UPS.
4. Using the wooden piece removed from the top of the UPS as a ramp, carefully slide the UPS off the pallet to its final position.
5. Reattach the side mounting brackets to increase the cabinet stability.
6. If desired, the mounting brackets can be fixed to the floor using M8 bolts.



WARNING: Water condensation may occur if the UPS is unpacked in a very low temperature environment. In this case, you must wait until the UPS is fully dried inside and outside before proceeding with the installation to avoid possible electric shock hazard and equipment malfunction.

3.4 Storage

UPS Cabinet

If you plan to store the UPS cabinet prior to use it should be held in a clean, dry environment with an ambient temperature between -5°C to $+60^{\circ}\text{C}$ (max $+35^{\circ}\text{C}$ for batteries) and RH $<95\%$. The UPS should preferably be stored in the original packing and shipping carton, but if the packing container is removed you must take measures to protect the UPS from dust.

Battery

The UPS uses sealed, maintenance-free batteries whose storage capacity depends on the ambient temperature. It is important not to store the batteries for longer than 6 months at 20°C , 3 months at 30°C , or 2 months at 35°C storage temperature without recharging them.

For longer term storage the batteries should be fully recharged every 6 months @ 20°C .



CAUTION: Sealed batteries must never be stored in a fully or partially discharged state. Extreme temperature, under-charge, overcharge or over-discharge will destroy batteries!

- Charge the battery both before and after storing.
- Always store the batteries in a dry, clean, cool environment in their original packaging.
- If the packaging is removed protect the batteries from dust and humidity.

3.5 Planning the installation (site considerations)

A certain amount of pre-planning will help ensure a smooth and trouble-free installation of the UPS system. The following guidelines should be taken into account when planning a suitable UPS location and operating environment.

1. The UPS is designed for indoor installation only.
2. The route to the installation location must allow the equipment to be transported in an upright position.
3. The floor at the proposed installation site and en-route from the off-loading point must be able to safely take the weight of the UPS and battery equipment plus fork lift during transit.
4. Locations with high ambient temperature, moisture or humidity must be avoided.
 - a) The installation site humidity should be $<90\%$ non-condensing.
 - b) The prescribed ambient temperature is 0°C to $+40^{\circ}\text{C}$. An ambient temperature of 20°C is recommended to achieve a long battery life.
 - c) Any requested cooling air flow must be available. The air entering the UPS must not exceed $+40^{\circ}\text{C}$.
 - d) The air conditioning system must be able to provide a sufficient amount of cooling air to keep the room within the prescribed temperature range.
5. The following environmental conditions should also be considered:
 - a) Fire protection standards must be respected. The floor material should be non-flammable.
 - b) The location must be free of dust and corrosive/explosive gases.
 - c) The location must be vibration free.
 - d) A minimum clearance of 50cm is required on the sides of the equipment to allow the free passage of cooling air

3: Installation

3.5.1 Clearances

The following notes are applicable to both the UPS and external battery cabinet.

The cabinet is force ventilated with extractor fans mounted on the back panel drawing cooling air through the inlet grills on the front of the unit. Sufficient space must be provided at the back and sides of the cabinet to permit adequate air-flow.

Rear access is required for connecting the power and control cables, and also to operate the UPS power switches. If direct rear access is not available, sufficient space must be provided at the side of the cabinet to allow the operator to reach around the cabinet to operate the power switches.

Note: Full access is required to both sides of the cabinet for maintenance.

The UPS cabinet is mounted on wheels, so if the installation does not afford direct side access the UPS connecting cables should be of sufficient length to allow the cabinet to be moved forward to offer unhindered side access when required.

We recommend the following minimum clearances:

- Rear access (X): a minimum of 500mm for unrestricted airflow
- Side (Y): a minimum of 500mm for free airflow, but may need increasing to 1000mm to afford rear access for operating the equipment power switches if direct rear access is not available (see also the note above)
- Front (Z): allow a minimum of 1000mm for maintenance access and the safe passage of personnel

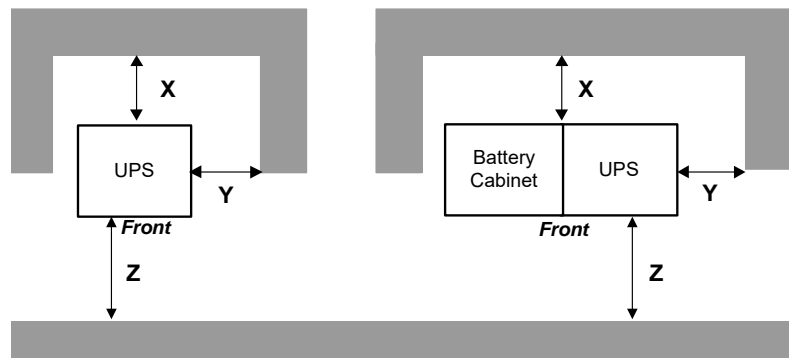

Clearance (mm)	X	Y	Z
Minimum	~500	500~1000	1000

Figure 3.2 UPS & Battery cabinet clearance requirements

3.6 Planning the installation (cabling considerations)

3.6.1 General requirements

The information in this section should help with the preparation and planning of the UPS power cabling.

It is the customer's responsibility to provide all external fuses, isolators and cables that are used to connect the UPS input and output power supplies. The UPS input and bypass terminals should be connected to the utility mains supply through a suitable LV-Distribution board containing a circuit breaker or fused isolator to provide both overload protection and a means of isolating the UPS from the mains supply when required. Similarly, the UPS AC output terminals should be connected to the load equipment via a suitably fused load distribution board.

Input neutral grounding

A permanently connected input neutral is required to enable the rectifier to operate correctly and allow the UPS to function properly when operating on battery. The input neutral must also be grounded to permit correct operation when the UPS is running on battery.

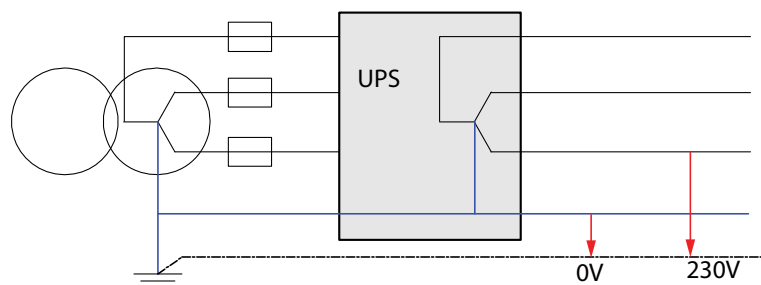

Figure 3.3 Permanent, grounded input neutral

and connected to the UPS at all times. DO NOT use, a 4-wire system on a TN-S system.

3.6.2 UPS Cable and fuse sizing



Key Point: The information in figures 3.8 and 3.9 is given for guidance only:

- Fuse and Cable recommendations are to IEC 60950-1:2001.
- All external fuses, isolators and power cables must be rated and installed in accordance with the prescribed IEC standards or local regulations:
 - e.g. BS7671: 2008 incorporating amendment No.1:2011.
- External DC Cables and battery fuses are bespoke to the installation.

3.6.3 Power cabling for a parallel system

In order to achieve equal load sharing between the UPS cabinets in a parallel system, the length of the input cables from the input distribution board to each cabinet should be as equal as possible, with a maximum difference of 20%. This also applies to the UPS output cables. Each module should be connected to an output circuit breaker located on a switch panel no further than 20 meters from the cabinets.

External maintenance bypass

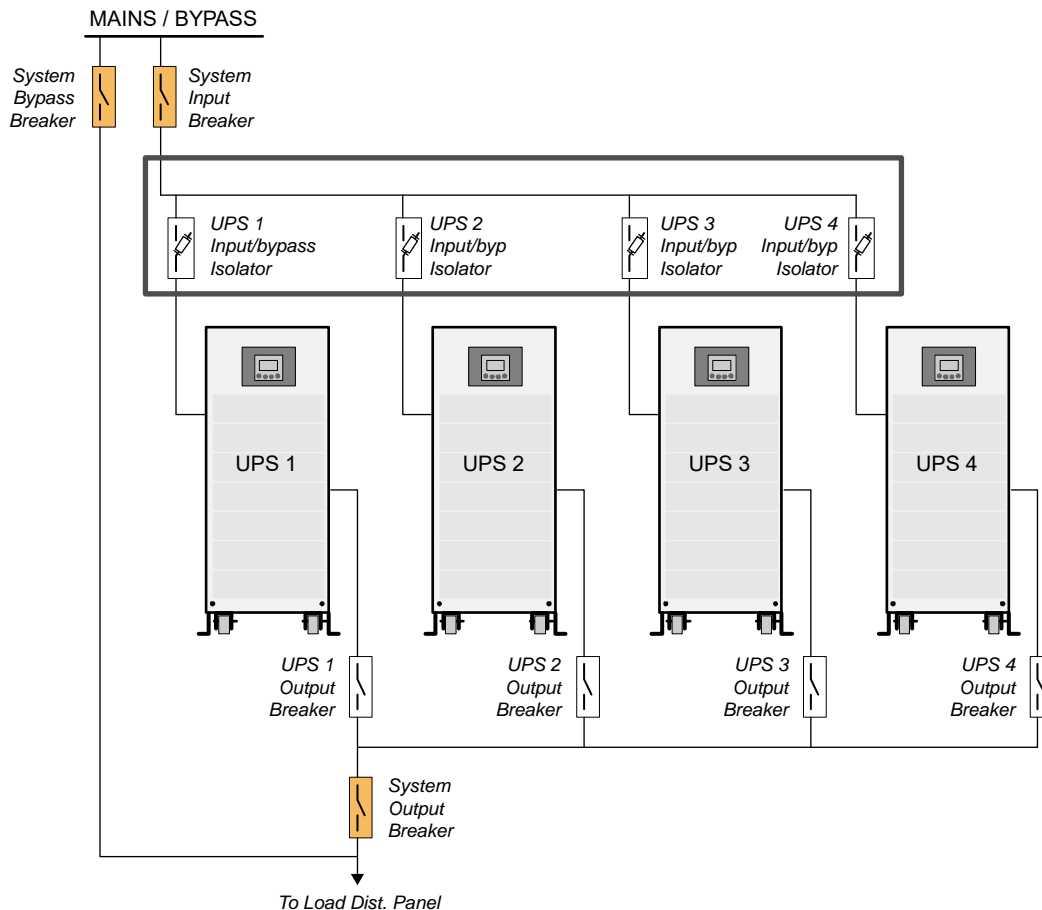

Figure 3.4 External bypass circuit

An external maintenance bypass facility, such as that shown in Figure 3.4, can be installed to increase the system flexibility. This circuit allows an individual module to be isolated from the system, for repair or total replacement, by opening its input fused isolator and Output Breaker. It also allows the total system to be bypassed by closing the System Bypass Breaker and opening the System Output Breaker; which in turn allows testing of the entire parallel system.

When such an external maintenance bypass is used it is crucial that the UPS modules are all operating on bypass (or internal maintenance bypass) before the System Bypass Breaker is closed, to avoid the possibility of module damage. For this reason it is usual to incorporate some form of safety interlocking mechanism around the external breakers.

3: Installation

3.6.4 UPS Terminal block connection details

The input, output and external battery power cables are connected to a terminal block rail located on the back of the UPS cabinet, behind a removable cover which is secured to the cabinet by four screws. Figure 3.5 shows the power terminal block connection details.

MAINS 1 – is connected to the UPS input mains supply and can be configured for either a single-phase or three-phase input supply.

MAINS 2 – is connected to the UPS bypass mains supply. This is a single-phase connection and it can either be linked to MAINS 1 (single input configuration) or connected to a dedicated bypass mains supply (dual input configuration). Note that the neutral connections for MAINS 1 and MAINS 2 are linked within the UPS.

The various MAINS 1 / MAINS 2 input configurations are described in paragraph 3.6.5

OUTPUT – The UPS AC output terminals should be connected to the load distribution panel via a circuit breaker or fused isolator.

PARALLEL JP – JP1/JP2 is used to configure the UPS for parallel operation. By default, the UPS is shipped with a link connected between JP1 and JP2 which configures the UPS for use as a stand-alone unit (single module).



CAUTION: If the UPS is to be installed as part of a parallel PW3000TP system the link between JP1-JP2 must be removed.

BATTERY – The battery terminals are used to connect the UPS cabinet to an external battery cabinet, where used.



CAUTION: The UPS is usually shipped with its internal batteries already connected.

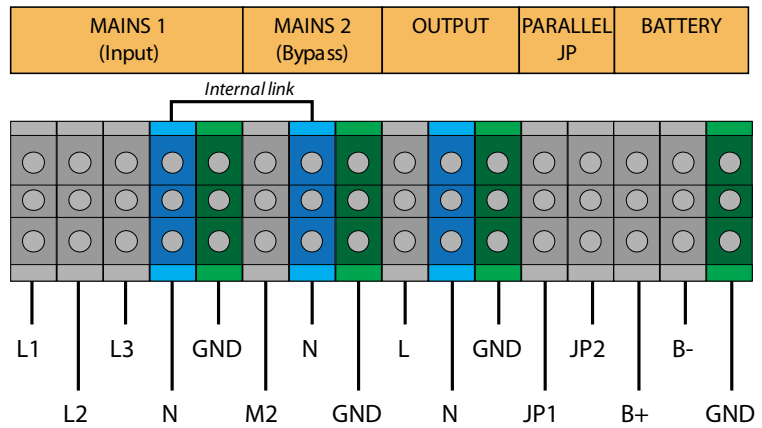

Figure 3.5 Power terminal block connections

3.6.5 Input/bypass supply configuration options

As mentioned above, the UPS input mains (MAINS 1) and bypass mains (MAINS 2) can be connected in several supply configurations. These can be described as:

- *Three phase dual input* – Three phase mains input (L1,L2,L3) and separate single phase bypass input (M2)
- *Three phase single input* – Three phase mains input (L1,L2,L3) with the bypass line (M2) linked to (L1)
- *Single phase dual input* – Single phase mains input (L1,L2,L3 linked) and separate single phase bypass line (M2)
- *Single phase single input* – Single phase mains input linked to the bypass input (L1,L2,L3,M2 all linked)

The input configuration is selected by fitting links to the power terminal block Mains 1 and Mains 2 connections. A 'jumper kit' comprising four screws, four spacers and a small busbar with 6-holes, is shipped with the UPS module to enable the UPS input supply connections to be linked accordingly. When installed, the jumper bar should be fitted to connections along the centre of the terminal block with the spacers as shown in Figure 3.6 and secured firmly in place by the required screws. Link details for all four configurations are shown in figures 3.8 to 3.11).

Note: If only the three left-most screws are required to be fitted, the bar can be cut to length.

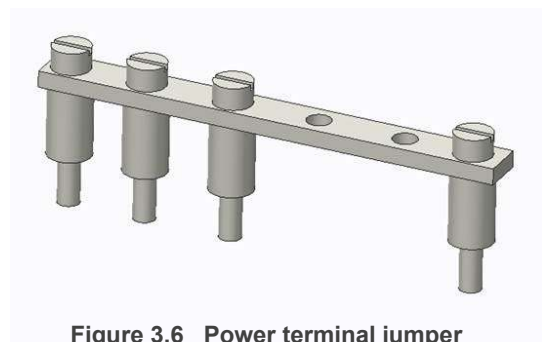

Figure 3.6 Power terminal jumper

3.7 Connecting the UPS power cables



WARNING: Opening or removing the UPS-covers will create a risk of exposure to dangerous voltages if power is connected to the UPS.

Safety notes

Please ensure you read and understand the following safety notes before you begin the UPS electrical installation.

1. Do not commence this procedure until the UPS mechanical installation has been completed.
2. All the cable installation procedures detailed below must be supervised by a qualified electrician.
3. Do not connect the UPS if there is water or moisture present.
4. When carrying out any work on the UPS power cables or terminals, you must ensure that the UPS input and output supplies are isolated and locked out at their respective distribution boards. Warning notices should be posted to prevent any inadvertent operation of the UPS mains supply isolators.
5. Once the electrical installation is completed the UPS must be commissioned by an engineer authorised by the manufacturer before it is brought into use.



WARNING: Do not apply electrical power to the UPS before it has been commissioned.

6. When installing the UPS cables ensure that the connection procedures are performed under the following conditions:
 - a) No mains voltage is present at the UPS mains (or bypass) distribution board terminals.
 - b) All loads are disconnected at the load distribution board and the UPS is fully shut down and voltage-free.
 - c) The UPS Maintenance Bypass Isolator is open (OFF).

3.7.1 Power cabling procedure



Figure 3.7 Power terminal connections



Key Point: The power terminal block, shown in detail in Figure 3.5, can accept cables up to 16mm² in the 10kVA unit. In the 20kVA unit the maximum terminal size is 35mm² but due to manipulation restrictions in the cable box we recommend using flexible cable with a maximum cable size of 25mm².

Note that the input neutral and bypass neutral terminals are linked at the terminal block.

To prepare for power cabling:

1. Remove the terminal block cover (1) to gain access to the terminal block connections.
2. All power cables enter the UPS through cable glands (2) fitted to the bottom of the terminal box. The holes used for the glands are fitted with blanks when the unit is shipped. Fit the supplied glands to suit the cable installation.
3. Connect the protective earth (GND) cables between the UPS power terminal block and each of the following:
 - a) input mains distribution panel
 - b) bypass mains distribution panel (if separate)
 - c) UPS output distribution panel
 - d) external battery cabinet (if used)
4. Connect the power cables to the terminal block according to the desired input configuration, as described in Figure 3.8 to Figure 3.11.



Key Point: The tables in Figure 3.8 to Figure 3.11 show the maximum current ratings for the cables and protective devices that must be provided by the customer. The chosen cables/protective devices must meet the required local standards and installed in accordance with codes of practice

3: Installation

3.7.2 Three phase dual input cabling details

	10kVA	20kVA
Cable A	16 A	33 A
Cable B	48 A	90 A
Cable C	48 A	90 A
Cable D	Bespoke	
Safety Earth	max 16 mm ²	max 25 mm ²

Note: @400V/230V nominal input.

WIRING NOTES

1. Connect the supply neutral to the bypass neutral terminal (Mains 2 (N)).
DO NOT connect the supply neutral to the input neutral terminal (Mains 1 (N)) as there is a possibility that the bypass current could return through, and overload, the smaller cable of Mains 1.
2. Connect the three-phase mains input cable to L1,L2,L3 and the bypass input cable to M2.
3. Connect the battery cables to the external battery cabinet if used (see paragraph 3.8).
4. Remove the link between JP1 and JP2 if the module is part of a parallel module system.
5. Connect the output terminals to the output breaker/load distribution board. The load distribution breakers should have a leakage current protective function to suit to the UPS voltage and current ratings.

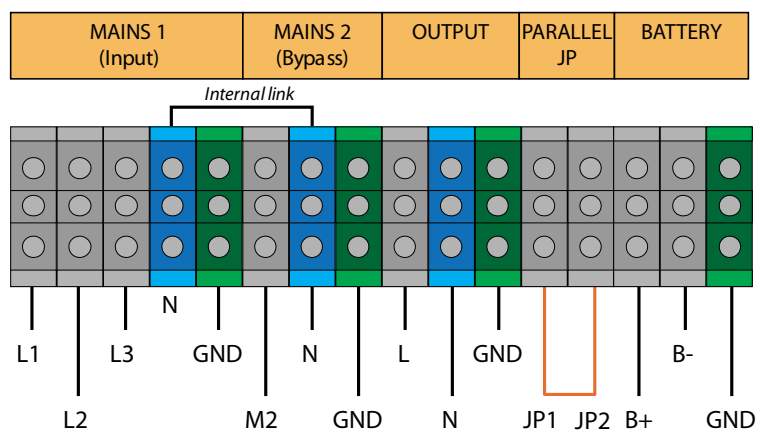
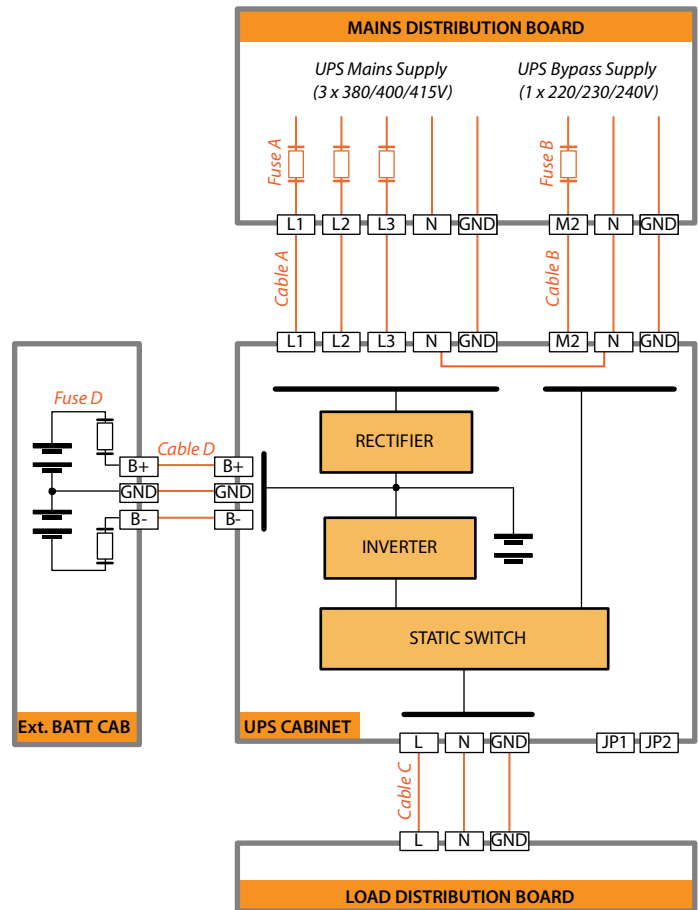

Figure 3.8 Three phase dual input diagram with recommended cable and fuse sizing

3.7.3 Three phase single input cabling details

	10kVA	20kVA
Cable A	16 A (48 A on L1)	33 A (90 A on L1)
Cable B	48 A	90 A
Cable C	48 A	90 A
Cable D	Bespoke	
Safety Earth	max 16 mm ²	max 25 mm ²

Note: @400V/230V nominal input.

WIRING NOTES

1. Connect the supply neutral cable to the bypass neutral terminal (Mains 2 (N)), which is also connected to the mains input neutral terminal within the UPS. There is no need to connect the input mains neutral (Mains 1 (N)).
2. Install the power terminal jumper between the Mains 1 (L1) and Mains 2 (M2).
3. Connect the mains input cable to L1, L2, L3.
4. Connect the battery cables to the external battery cabinet if used (see paragraph 3.8).
5. Remove the link between JP1 and JP2 if the module is part of a parallel module system.
6. Connect the output terminals to the output breaker/load distribution board. The load distribution breakers should have a leakage current protective function to suit to the UPS voltage and current ratings.

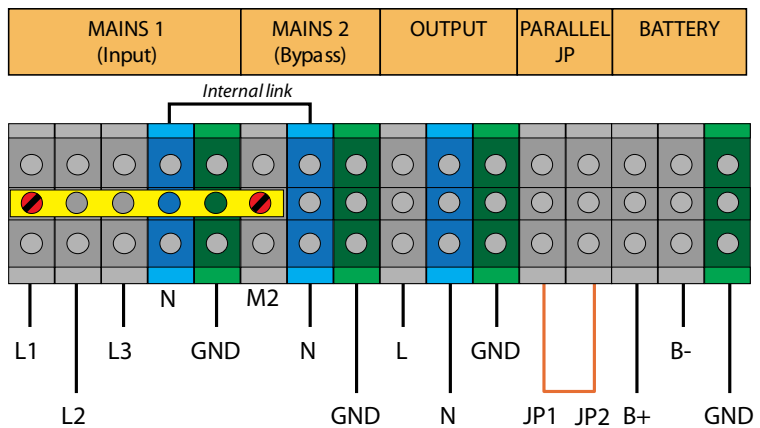
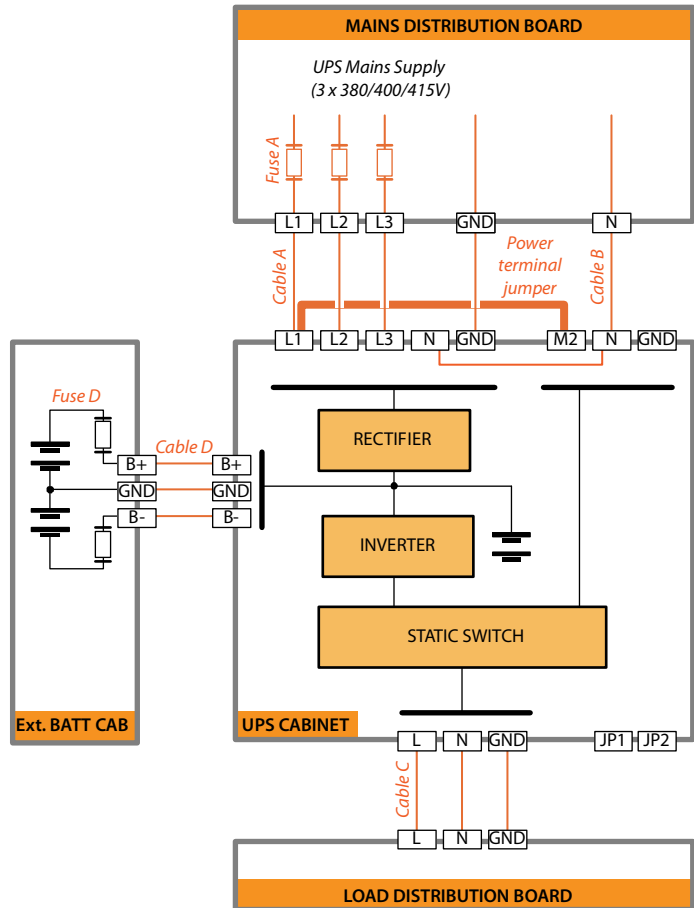

Figure 3.9 Three phase single input diagram with recommended cable and fuse sizing

3: Installation

3.7.4 Single phase dual input cabling details

	10kVA	20kVA
Cable A	48 A	90 A
Cable B	48 A	90 A
Cable C	48 A	90 A
Cable D	Bespoke	
Safety Earth	max 16 mm ²	max 25 mm ²

Note: @400V/230V nominal input.

WIRING NOTES

1. Connect the input neutral cables to Mains 1 (N) and Mains 2 (N).
2. Install the power terminal jumper between Mains 1 (L1, L2, L3).
3. Connect the input line cable to Mains 1 (L1).
4. Connect the bypass line cable to Mains 2 (M2).
5. Connect the battery cables to the external battery cabinet if used (see paragraph 3.8).
6. Remove the link between JP1 and JP2 if the module is part of a parallel module system.
7. Connect the output terminals to the output breaker/load distribution board. The load distribution breakers should have a leakage current protective function to suit to the UPS voltage and current ratings.

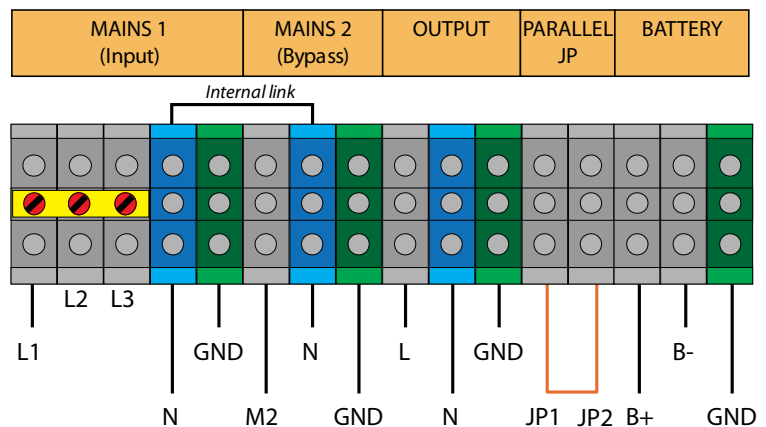
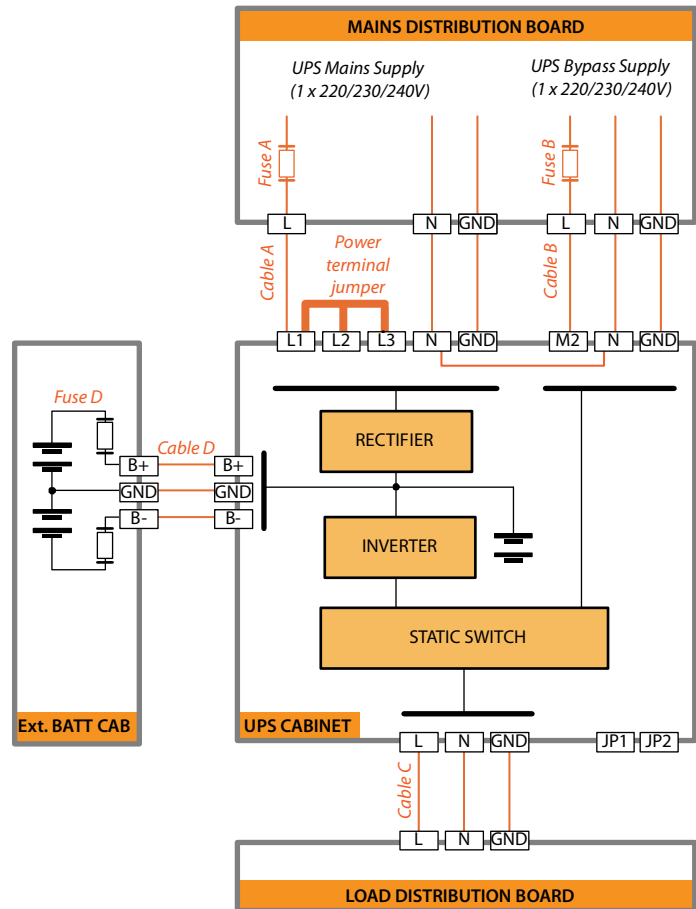

Figure 3.10 Single phase dual input diagram with recommended cable and fuse sizing

3.7.5 Single phase single input cabling details

	10kVA	20kVA
Cable A	48 A	90 A
Cable B	48 A	90 A
Cable C	48 A	90 A
Cable D	Bespoke	
Safety Earth	max 16 mm ²	max 25 mm ²

Note: @400V/230V nominal input.

WIRING NOTES

1. Connect the supply neutral cable to the bypass neutral terminal (Mains 2 (N)), which is also connected to the mains input neutral terminal within the UPS. There is no need to connect the input mains neutral (Mains 1 (N)).
2. Install the power terminal jumper between Mains 1 (L1, L2, L3) and Mains 2 (M2).
3. Connect the input line cable to Mains 1 (L1).
4. Connect the battery cables to the external battery cabinet if used (see paragraph 3.8).
5. Remove the link between JP1 and JP2 if the module is part of a parallel module system.
6. Connect the output terminals to the output breaker/load distribution board. The load distribution breakers should have a leakage current protective function to suit to the UPS voltage and current ratings.

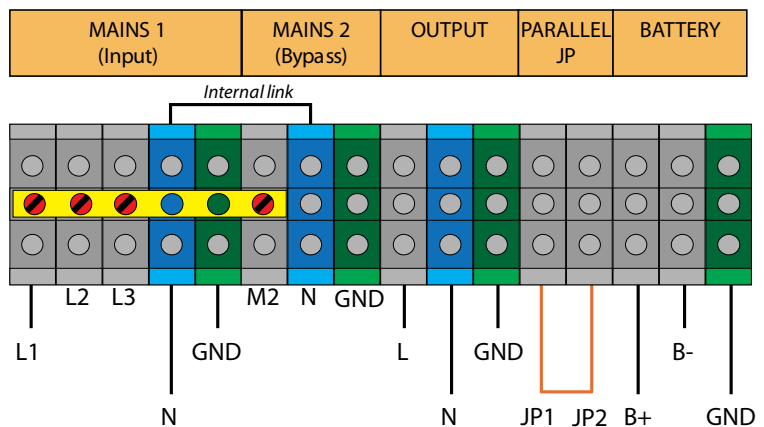
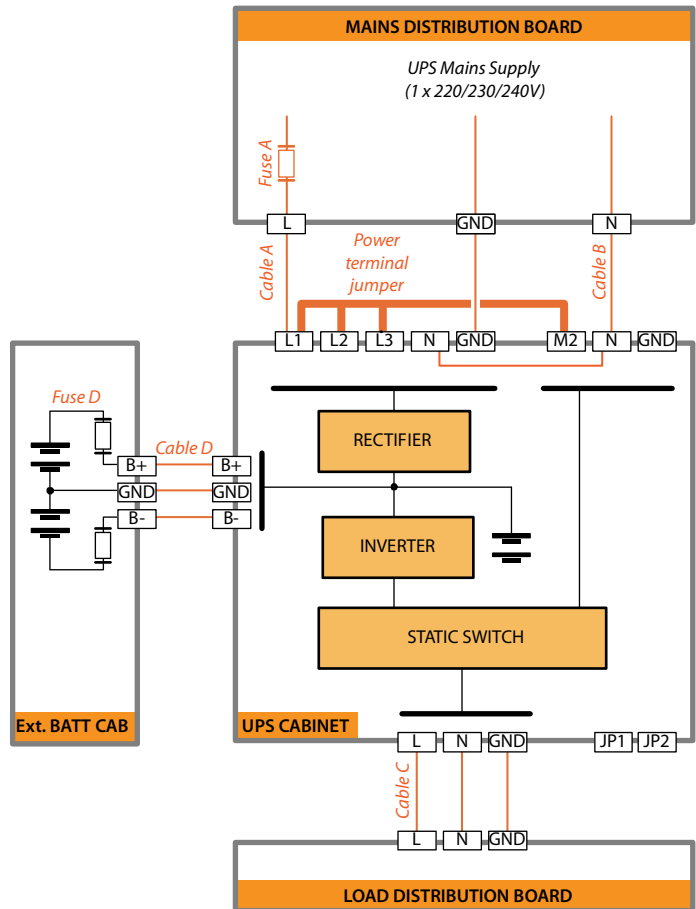

Figure 3.11 Single phase single input diagram with recommended cable and fuse sizing

3.8 Battery cabling procedure

Safety Notes



WARNING: Opening or removing the UPS/Battery enclosure covers will create the risk of exposure to dangerous voltages if power is connected to the UPS. Battery replacement and connections should only be carried out by electrically qualified personnel.

If the UPS is delivered without batteries, Uninterruptible Power Supplies Ltd is not responsible for any damage or malfunction caused to the UPS by the incorrect storage, installation or connection of batteries by third parties.

Final battery connection must be supervised by the commissioning engineer. Do not attempt to complete the battery wiring or close any battery isolator before the system has been commissioned.

3.8.1 Internal battery connections

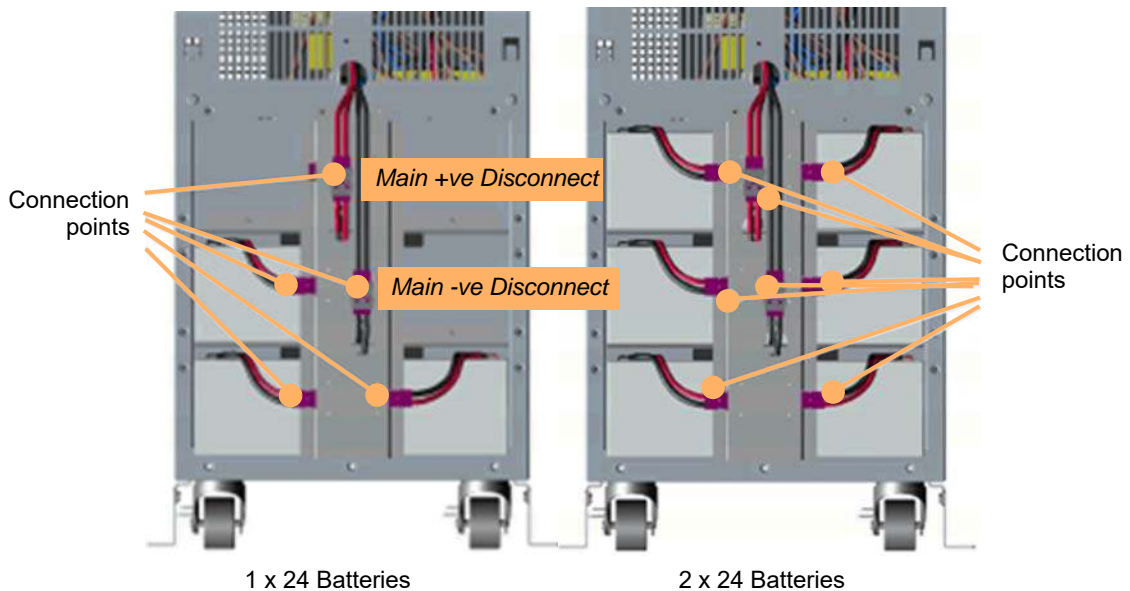

Figure 3.12 UPS Cabinet internal batteries

The UPS cabinet internal batteries are mounted on three shelves at the bottom of the cabinet and connected together as shown. All connections are accessible from the front of the cabinet after removing the front panel. Each battery string consists of 24 x 12V batteries connected in series to provide a nominal battery voltage of 288V; and two battery strings, each containing 24 batteries, can be housed and connected in parallel to increase the battery capacity.

Normally, internal batteries are shipped securely fitted to the cabinet battery trays and fully connected, and no further action is required when connecting the UPS power cables.

3.8.2 External battery cabinet cabling procedure



Key Point: This section is required only if an external battery cabinet is installed.

Where an external battery cabinet is installed it contains additional battery strings (each comprising 24 x 12V batteries) which are connected in parallel with the UPS internal batteries.



WARNING: Do not close the fused isolators in the battery cabinet before the UPS system is commissioned.

1. Disconnect the UPS internal batteries at the 'Main + Disconnect' and 'Main – Disconnect' points shown in Figure 3.12.
2. Open the fuse isolator on the back of the battery cabinet (see Figure 2.8).
3. Remove the terminal block cover on the back of the battery cabinet to gain access to the main terminal block.
4. Connect the protective earth cable (GND) between the battery GND terminal on the UPS terminal block (see Figure 3.8 to Figure 3.11) and the GND terminal on the battery cabinet terminal block.
5. Connect the battery positive (B+) and negative (B-) terminals on the UPS terminal block (see Figure 3.8 to Figure 3.11) to the corresponding B+ and B- terminals on the battery cabinet terminal block.
6. Reconnect the UPS internal batteries at the 'Main + Disconnect' and 'Main – Disconnect' that were disconnected earlier.
7. Refit the battery cabinet terminal block cover. Do not close the battery fuses on the battery cabinet until the system has been commissioned.

3.9 Multi-cabinet configuration and paralleling cables



Key Point: This section is required only if two (or more) cabinets are connected as a parallel system.

1. Ensure the cable link is removed from JP1-JP2 on the UPS terminal block (see Figure 3.8 to Figure 3.11).
2. For all modules, remove the parallel port cover plate on the rear of the UPS (see item 12 in Figure 2.7).
3. Connect a parallel bus cable (25-pin, 3m cables supplied) between the parallel ports of each UPS in a daisy chain.
4. Fit the modified parallel port cover plate (supplied) to the rear of the UPS, taking care not to trap the cables.

3.10 Optional remote monitoring and control facilities

Fit and connect any optional equipment following the instructions in Chapter 7.

- Back-feed protection - see page 52
- Emergency Power-OFF (EPO) - see page 53
- Computer communication options. - see page 53
- Serial Network Management (SNMP) card - see page 54
- AS400 Interface card - see page 55
- UPS Monitoring and automated control software - see page 56

4

Operating procedures

4.1 Introduction

The PowerWave PW3000/TP UPS system must be commissioned by a fully trained field service engineer authorised by Uninterruptible Power Supplies Ltd. before it is put into use.

The commissioning engineer will:

- Connect the UPS batteries
- Check the UPS mechanical and electrical installation, and operating environment
- Check the UPS cabinet parallel configuration settings
- Check the correct installation of any optional equipment
- Perform a controlled UPS start-up and functionally test the system for correct operation and configuration
- Carry out customer operator training and equipment handover



WARNING: Uninterruptible Power Supplies Ltd. accepts no responsibility for the equipment or the safety of any personnel when operating this equipment before it has been properly commissioned. The manufacturer's warranty is immediately invalidated if power is applied to any part of the UPS system before it has been fully commissioned and handed over to the customer.



WARNING: Before you operate this equipment you should understand the location and function of the UPS controls, as described in Chapter 2.4 and Chapter 2.5, together with all associated external switchgear and distribution panels.

4.1.1 Operating procedure summary

A typical PowerWave PW3000/TP installation is shown in Figure 4.1.

This chapter contains the following procedures:

- Paragraph 4.2 Single module start-up – with mains supply
- Paragraph 4.3 Single module start-up – without mains supply
- Paragraph 4.4 Single module – changing the operating mode
- Paragraph 4.5 Single module shut down – with mains supply present
- Paragraph 4.6 Single module shutdown – with UPS on battery
- Paragraph 4.7 Single module – using the internal maintenance bypass
- Paragraph 4.8 Parallel module system procedures
- Paragraph 4.9 Parallel system start-up
- Paragraph 4.10 Parallel system – changing the operating mode
- Paragraph 4.11 Parallel system – start/stop one module
- Paragraph 4.12 Parallel module complete system shut-down
- Paragraph 4.13 External Maintenance Bypass operation
- Paragraph 4.14 Operating a frequency changing system
- Paragraph 4.15 Emergency Stop

4.2 Single module start-up – with mains supply

Use this procedure to start a single module UPS system from a completely powered down condition.

1. Check that all the loads connected to the UPS are turned off.
2. Close the external UPS Input/bypass Isolators as required to connect power to the UPS.
3. If an external battery cabinet is used, close the fused isolator on the back of the battery cabinet together with any circuit breaker connected in the battery line.
4. On the back of the UPS cabinet, close the input breakers M1 and M2 (position ON).
 - a) The fans will start running.
 - b) The UPS will perform a self-test and will then display the default screen on the LCD.
5. On the UPS Control Panel, press the ON/OFF key for more than one second.
 - a) The alarm buzzer will sound and the UPS will start.
 - b) After a few seconds, the UPS will switch to its 'on-line' mode.
6. Check that the LCD indicates the 'on-line' status and no warning alarms are present.
7. The UPS is now fully operational and providing protected output power.
8. You can now switch on the loads.
(If possible, turn on the loads sequentially to prevent a UPS overload occurring due to combined inrush currents.)

4.3 Single module start-up – without mains supply

If there is no mains supply present, you can use this procedure to start a single module UPS system using battery power (also described as a 'cold start').



Key Point: When starting the UPS in this manner the batteries will immediately begin to discharge. If you want to sustain power to the load it is important that the mains supply is restored before the UPS shuts down due to the battery reaching its 'end of discharge' voltage.

1. Check that all the loads connected to the UPS are turned off.
2. Close the external UPS Input/bypass Isolators as required to connect power to the UPS.
3. If an external battery cabinet is used, close the fused isolator on the back of the battery cabinet together with any circuit breaker connected in the battery line.
4. On the back of the UPS cabinet, close the input breakers M1 and M2 (position ON).
 - a) Nothing will happen if the input supplies are not present.
5. On the UPS Control Panel, press the ON/OFF key for more than one second.
 - a) The fans will start running.
 - b) The UPS will perform a self-test and will then display the default menu on the LCD.
6. Press the ON/OFF key again for more than one second.
 - a) The alarm buzzer will sound and the UPS will start.
 - b) After a few seconds, the UPS will switch to its 'on-battery' mode.
7. Check that the LCD indicates the 'on-battery' status and no warning alarms are present other than those associated with the 'battery on load' status.
8. The UPS is now fully operational and providing protected output power, but the battery is on load and discharging (with the accompanying alarms).
9. You can now switch on the loads.
(If possible, turn on the loads sequentially to prevent a UPS overload occurring due to combined inrush currents.)
 - a) If the UPS is left to run in this condition sufficiently long, the battery will fully discharge and the UPS will shut down with the loss of the output supply.
 - b) If the mains supply is restored while the UPS is 'on-battery' it will automatically switch to 'on-line' mode.

4.4 Single module – changing the operating mode

When the UPS is turned on you can quickly switch between its various operating modes as shown below:

From	To	Action
ON-LINE	ON-BYPASS	*Press the ON/OFF key for 3 seconds.
ON-BYPASS	ON-LINE	Press the ON/OFF key for 3 seconds.
ON-BYPASS	ON-BATTERY	Isolate the mains/bypass power supply.
ON-BATTERY	ON-LINE	Restore the mains.bypass power supply.
* If the bypass is disabled in the <i>SETTINGS</i> menu, when operating in the ON-LINE mode pressing the ON/OFF key for three seconds will switch the UPS ON-BATTERY mode.		

4.5 Single module shut down – with mains supply present

Use this procedure to totally shut down a single module UPS system and its connected load.

1. Switch off the individual load items.
2. If the UPS is operating in 'on-bypass' mode go to step 4.
3. On the Control Panel, press the ON/OFF key continuously for more than three seconds.
 - a) The alarm buzzer will sound.
 - b) The UPS will transfer to 'on-bypass' mode and its output will remain live through the (unprotected) bypass supply.

Note: If the bypass has been disabled through the Settings menu, when you press the ON/OFF key for more than three seconds to shut down the UPS the unit will change from 'on-line' to 'on-battery' mode (see below).
4. On the back of the UPS cabinet, open the input breakers M1 and M2 (position OFF).
 - a) Power will be removed from the UPS output terminals
 - b) The fans will stop.
 - c) After a few seconds the UPS LCD display will power down.
5. To totally isolate the UPS, open the UPS Input/bypass Isolators and, where used, open the external battery cabinet fuses/isolator.



WARNING: With the UPS shut down allow at least 5 minutes for the UPS DC capacitors to discharge before gaining internal access.

4.6 Single module shutdown – with UPS on battery

1. Turn off the individual load items.
2. On the Control Panel, press the ON/OFF key continuously for more than three seconds.
 - a) The alarm buzzer will sound for three seconds
 - b) The output power will be immediately cut-off.
 - c) The fans will stop.
 - d) After a few seconds the UPS LCD display will power down.
3. To totally isolate the UPS, open the UPS Input/bypass Isolators and, where used, open the external battery cabinet fuses/isolator.



WARNING: With the UPS shut down allow at least 5 minutes for the UPS DC capacitors to discharge before gaining internal access.

4.7 Single module – using the internal maintenance bypass

The inbuilt maintenance bypass circuit allows the UPS to be powered down while maintaining the load through the (unprotected) bypass supply.



CAUTION: This mode is normally used only by fully trained UPS service engineers when gaining internal access to the UPS. It is not required during normal UPS operation or use.

Transferring the load from UPS to the internal Maintenance bypass

1. Check the SETTINGS menu to ensure that the [Auto Bypass] is enabled – see paragraph 2.6.5.
2. If the UPS is operating in the 'on-line' mode, press the ON/OFF key on the Control Panel continuously for more than three seconds.
 - a) The alarm buzzer will sound.
 - b) The UPS will transfer to 'on-bypass' mode and its output will remain live through the bypass supply.
3. Remove the Maintenance Switch cover plate on the back of the UPS.
4. Switch the Maintenance Switch from 'UPS' to 'BPS'.
 - a) The load is now powered from the unprotected UPS bypass supply via the Maintenance Switch.
 - b) The UPS can now be powered down (e.g. for repair) by opening the input breakers M1 and M2 (position OFF) on the back of the UPS together with the external battery cabinet fuses/isolator (where used).



WARNING: With the UPS shut down allow at least 5 minutes for the UPS DC capacitors to discharge before gaining internal access.



WARNING: Even with the UPS input breakers M1 and M2 open, potentially lethal voltages are still present within the unit.

Transferring the load from the internal Maintenance bypass to the UPS

1. If an external battery cabinet is used, check that the fuses/isolator on the back of the battery cabinet is closed and any circuit breaker connected in the battery line is closed.
2. On the back of the UPS cabinet, close the input breakers M1 and M2 (position ON).
 - a) The fans will start running.
 - b) The UPS will perform a self-test and will then display the default menu on the LCD.
3. Switch the Maintenance Switch from 'BPS' to 'UPS'.
4. Refit the Maintenance Switch cover plate on the back of the UPS.
 - a) The UPS will now be running with the load on bypass.
5. On the UPS Control Panel, press the ON/OFF key for more than one second.
 - a) The alarm buzzer will sound and the UPS will start.
 - b) After a few seconds, the UPS will switch to its 'on-line' mode.
6. Check that the LCD indicates the 'on-line' status and no warning alarms are present.
7. The UPS is now fully operational and providing protected output power.

4.8 Parallel module system procedures

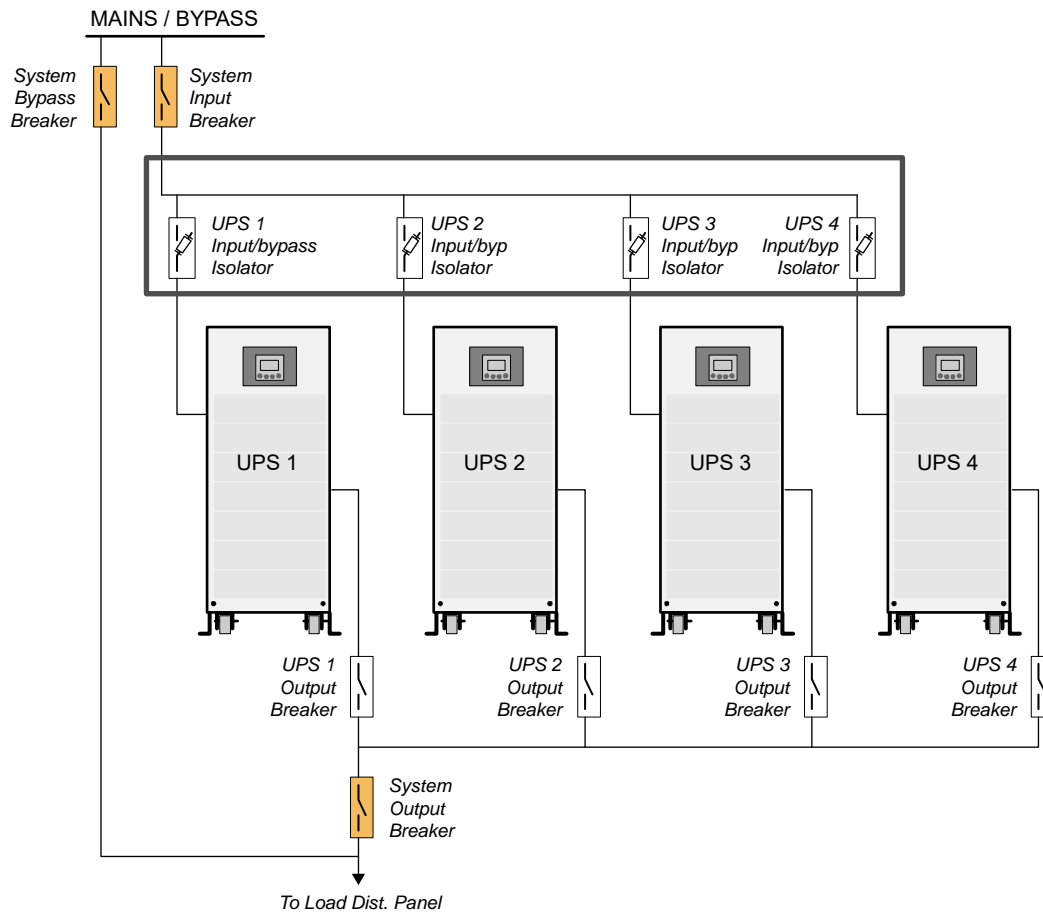

Figure 4.1 External maintenance bypass circuit

In a parallel module system each module will be connected to individual external module input and output isolators, together with a System Output Breaker that connected the combined modules' output to the load distribution panel. It is also likely that the system will include a 'wrap-around' maintenance bypass circuit, comprising a System Input Breaker and System Bypass Breaker, similar to that shown in Figure 4.1.

Before using the parallel module system operating procedures given below you should familiarise yourself with any site-specific external switching arrangements and modify the procedures accordingly.



Key Point: The UPS commissioning engineer will explain the function of any external power isolators and maintenance bypass operation during the system handover.

4.9 Parallel system start-up

Use this procedure to start a multi-module parallel UPS system from a completely powered down condition.

1. Check that all the loads connected to the UPS are turned off.
2. Check that the individual modules' Output Breakers and the System Output Breaker are all open.

On each module in turn

3. Close the external UPS Input/bypass Isolators as required to connect power to the UPS.
4. If an external battery cabinet is used, close the fused isolator on the back of the battery cabinet together with any circuit breaker connected in the battery line.
5. On the back of the UPS cabinet, close the input breakers M1 and M2 (position 0N).
 - a) The fans will start running.
 - b) The UPS will perform a self-test and then display the default menu on the LCD.
6. Check that no abnormal conditions are shown on any of the modules' LCD panel.

System start-up

7. On the UPS Control Panel of ANY module, press the 0N/OFF key for more than one second.
 - a) The alarm buzzer will sound and ALL the UPS modules will start.
 - b) After a few seconds, ALL the UPS modules should switch to the 'on-line' mode simultaneously.
8. Check that no abnormal conditions are shown on any of the modules' LCD panel.
9. On any one of the UPS modules, press the 0N/OFF key continuously for more than three seconds.
 - a) All UPS modules will transfer to 'on-bypass' mode simultaneously.
10. Check that no abnormal conditions are shown on any of the modules' LCD panel.
11. Close the output breaker on ALL modules to parallel the UPS output.
12. On any one of the UPS modules, press the 0N/OFF key continuously for more than three seconds.
 - a) All the UPS modules will switch to the 'on-line' mode.
13. Close the System Output Breaker, to connect the UPS output to the load distribution panel.
14. The parallel UPS system is now fully operational and providing protected output power.
15. You can now switch on the loads.
 (If possible, turn on the loads sequentially to prevent any UPS overloads occurring due to combined inrush currents.)

4.10 Parallel system – changing the operating mode

When the parallel system is turned on and operational you can quickly switch between its various operating modes as shown below:

From	To	Action
ON-LINE	ON-BYPASS	*Press the 0N/OFF key for 3 seconds on ANY module.
ON-BYPASS	ON-LINE	Press the 0N/OFF key for 3 seconds on ANY module.
ON-BATTERY	ON-LINE	Restore the mains.bypass power supply.
* If the bypass is disabled in the <i>SETTINGS</i> menu, when pressing the 0N/OFF key for three seconds the UPS will go from ON-LINE to ON-BATTERY mode.		

4: Operating procedures

4.11 Parallel system – start/stop one module

If a parallel system includes a redundant module, you can use this procedure to stop or start an individual module without affecting the UPS critical load power.

To turn OFF one module

1. From the default screen, press the DOWN key for one second, press the Main Menu.
2. Scroll to the 'Turn OFF Single Module' screen, as shown [A].
3. Press the SELECT key.
 - a) The cursor will flash on NO.
4. If you want to turn OFF the module use the UP/DOWN keys so that the cursor indicates YES, then select it by pressing the SELECT key for more than one second [B].
5. The UPS module will turn OFF without affecting the rest of the system.
6. To isolate the shut-down module open its external input and output breakers and isolate the external battery cabinet fuses if used.

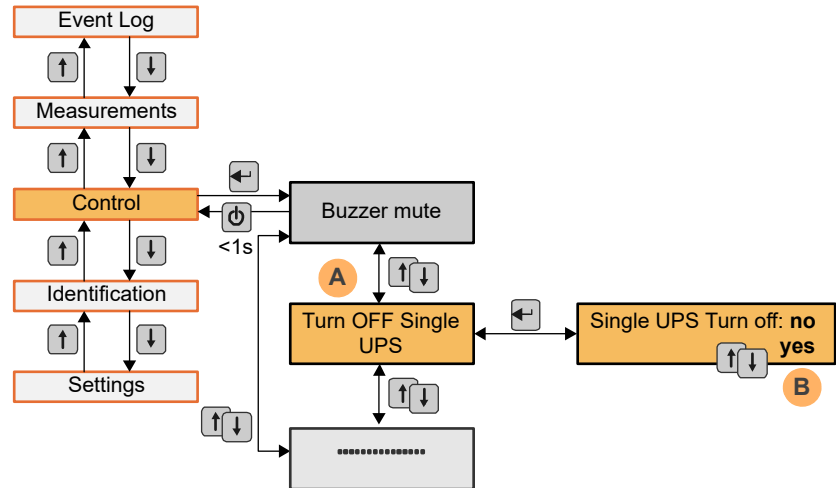

Figure 4.2 Turning of one module in a parallel system



WARNING: With the UPS shut down allow at least 5 minutes for the UPS DC capacitors to discharge before gaining internal access.

To turn on the module

1. Ensure the module's external Output Breaker is open.
2. Close the external UPS Input/bypass Isolators as required to connect power to the UPS.
3. If an external battery cabinet is used, close the fused isolator on the back of the battery cabinet together with any circuit breaker connected in the battery line.
4. On the back of the UPS cabinet, close the input breakers M1 and M2 (position 0N).
 - a) The fans will start running.
 - b) The UPS will perform a self-test and will then display the default menu on the LCD.
5. On the UPS Control Panel, press the ON/OFF key for more than one second.
 - a) The alarm buzzer will sound and the UPS will start.
 - b) After a few seconds, the UPS will switch to its 'on-line' mode.
6. Check that the LCD indicates the 'on-line' status and no warning alarms are present.
7. Close the module's external Output Breaker.
8. The UPS is now fully operational and providing protected output power in parallel with the other system modules.

4.12 Parallel module complete system shut-down

Use this procedure to totally shut-down and power off multi-module UPS system

1. Turn off the individual load items.
2. Open the System Output Breaker.
3. Open the individual UPS Output Breakers.

If the modules are 'on-line'

4. On the Control Panel of ANY on-line module, press the ON/OFF key continuously for more than three seconds.
For ALL modules:
 - a) The alarm buzzer will sound.
 - b) The UPS will transfer to 'on-bypass' mode and its output will remain live through the (unprotected) bypass supply.
5. Go to step 9.

If the modules are 'on-bypass'

6. Go to step 9.

If the modules are 'on-battery'

7. On the Control Panel of ANY module, press the ON/OFF key continuously for more than three seconds.
For ALL modules:
 - a) The alarm buzzer will sound for three seconds
 - b) The output power will be immediately cut-off.
 - c) The fans will stop.
 - d) After a few seconds the UPS LCD display will power down.
8. Go to step 9.

All Modes

9. On the back of each UPS cabinet in turn, open the input breakers M1 and M2 (position OFF).
 - a) Power will be removed from the UPS output terminals
 - b) The fans will stop.
 - c) After a few seconds the UPS LCD display will power down.
10. To totally isolate the modules, open the external mains/bypass power Input Isolators and, where used, open the external battery cabinet fuses/isolator.



WARNING: With the UPS shut down allow at least 5 minutes for the UPS DC capacitors to discharge before gaining internal access.

4.13 External Maintenance Bypass operation

An external maintenance bypass circuit, such as that shown in Figure 4.1, allows the UPS system to be totally powered down while maintaining the load supply through the (unprotected) bypass supply.



CAUTION: This mode is normally used only by fully trained UPS service engineers, for example when repairing/replacing a UPS system, and is not generally required during normal UPS system operation or use.

Transferring the load from the UPS to the external bypass

1. On the Control Panel of ANY module, press the ON/OFF key continuously for more than three seconds.
For ALL modules:
 - a) The alarm buzzer will sound.
 - b) The UPS will transfer to 'on-bypass' mode and its output will remain live through the (unprotected) bypass supply.
2. Close the external System Bypass Breaker.
3. Open the System Output Breaker.
4. The load is now powered entirely through the (unprotected) external maintenance bypass supply.

To shutdown the UPS modules

5. Open the individual modules' Output Breakers.
6. On the back of each UPS cabinet in turn, open the input breakers M1 and M2 (position OFF).
 - a) Power will be removed from the UPS output terminals
 - b) The fans will stop.
 - c) After a few seconds the UPS LCD display will power down.
7. To totally isolate the UPS modules, open the UPS Input/bypass Isolators and, where used, open the external battery cabinet fuses/isolator.

Transferring the load from the external bypass to the UPS

On each UPS module in turn

1. Close the external Input/bypass Isolators as required to connect power to the UPS.
2. If an external battery cabinet is used, close the fused isolator on the back of the battery cabinet together with any circuit breaker connected in the battery line.
3. On the back of the UPS cabinet, close the input breakers M1 and M2 (position ON).
 - a) The fans will start running.
 - b) The UPS will perform a self-test and will then display the default menu on the LCD.
4. Check that no abnormal conditions are shown on any of the modules' LCD panel.

System start-up

5. On the UPS Control Panel of ANY module, press the ON/OFF key for more than one second.
 - a) The alarm buzzer will sound and ALL the UPS modules will start.
 - b) After a few seconds, ALL the UPS modules should switch to the 'on-line' mode simultaneously.
6. Check that no abnormal conditions are shown on any of the modules' LCD panel.
7. On any one of the UPS modules, press the ON/OFF key continuously for more than three seconds.
 - a) All UPS modules will transfer to 'on-bypass' mode simultaneously.
8. Check that no abnormal conditions are shown on any of the modules' LCD panel.
9. Close the external Output Breaker on ALL modules to parallel the UPS output.
10. Close the System Output Breaker, to connect the UPS ('on-bypass') output to the load distribution panel.
11. Open the external System Bypass breaker.
12. On any one of the UPS modules, press the ON/OFF key continuously for more than three seconds.
13. All UPS modules will transfer to 'on-line' mode simultaneously.

14. The parallel UPS system is now fully operational and providing protected output power.

4.14 Operating a frequency changing system

In a frequency changing system the UPS output frequency is different to its input frequency and therefore it is not possible to implement any form of bypass circuit.

4.14.1 Frequency changer – starting the UPS

1. Check that all the loads connected to the UPS are turned off.
2. Close the external UPS Input/bypass Isolators as required to connect power to the UPS.
3. If an external battery cabinet is used, close the fused isolator on the back of the battery cabinet together with any circuit breaker connected in the battery line.
4. On the back of the UPS cabinet, close the input breakers M1 and M2 (position ON).
 - a) The fans will start running.
 - b) The UPS will perform a self-test and will then display the default menu on the LCD.
5. In the case of a multi-module system repeat the above procedure for ALL modules
6. On the UPS Control Panel, press the ON/OFF key for more than one second (on ANY module in a multi-module system).
 - a) The alarm buzzer will sound and the UPS will start.
 - b) After a few seconds, the UPS (system) will switch to its 'on-line' mode.
7. Check that the LCD indicates the 'on-line' status and no warning alarms are present.
8. The UPS is now fully operational and providing protected output power.
9. You can now switch on the loads.
(If possible, turn on the loads sequentially to prevent any UPS overloads occurring due to combined inrush currents.)

4.14.2 Frequency changer – stopping the UPS

Use this procedure to totally shut down a frequency changer system and its connected load.

1. Turn off the individual load items.
2. On the Control Panel, press the ON/OFF key continuously for more than three seconds (on ANY module in a parallel system).
 - a) The alarm buzzer will sound for three seconds
 - b) The output power will be immediately cut-off.
 - c) The fans will stop.
 - d) After a few seconds the UPS LCD display will power down.
3. To totally isolate the UPS, open the UPS Input/bypass Isolators and, where used, open the external battery cabinet fuses/isolator.



WARNING: With the UPS shut down allow at least 5 minutes for the UPS DC capacitors to discharge before gaining internal access.

4: Operating procedures

4.15 Emergency Stop

Details for the Emergency Power Off (EPO) circuit operation is given in Paragraph 7.2.

If the EPO circuit is activated it must be cleared through an LCD menu before the UPS can be returned to normal use.

To clear an EPO operation

1. From the default screen, press the DOWN key for one second to access the Main Menu.
2. Scroll to the 'Clear EPO Status' screen, as shown [A].
3. Press the SELECT key.
 - a) The cursor will flash on NO.
4. If you want to clear the EPO status use the UP / DOWN keys so that the cursor indicates YES, then select it by pressing the SELECT key for less than one second [B].
5. The EPO status will now be cleared.
6. Scroll back to the default LCD display.

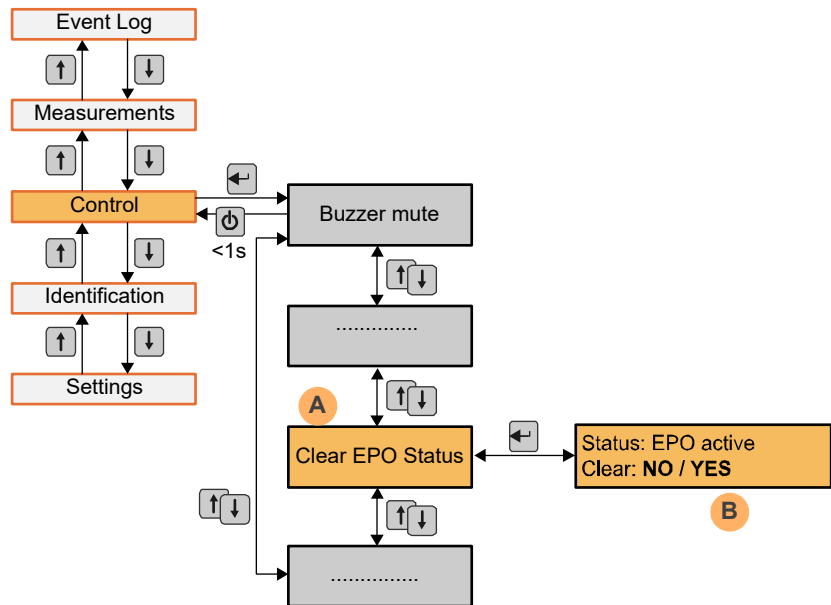

Figure 4.3 Clearing the EPO operation

5 Maintenance

5.1 Introduction



WARNING: The UPS contains hazardous voltages even when switched off.

WARNING: Do not remove the UPS covers unless you are electrically qualified and trained on the equipment type by the manufacturer (Uninterruptible Power Supplies Ltd) or one of its service agents.

WARNING: There are no user-serviceable part contained within the UPS.

WARNING: Any operation described in this chapter that requires internal access to the UPS or external battery cabinets must be performed by authorised service personnel.

5.2 System calibration

To ensure optimum UPS operation and continuous, efficient protection of the connected load, it is recommended that the system's operating parameters are checked every six months and recalibrated where necessary. The batteries should also be checked every six months, depending on the ambient temperature.

5.3 User responsibilities

As there are no user-serviceable parts contained within the UPS, the maintenance required by the user are minimal apart from keeping the equipment clean and monitoring the working environment to ensure it is kept cool and dust-free. This will maximise the useful working life and reliability of the UPS and its batteries.

5.4 Routine maintenance

It is essential that the UPS system and batteries receive regular preventative maintenance inspection. When the UPS is commissioned, the commissioning field service engineer will attach a service record book to the UPS which will be used to log the full service history of the UPS.

Preventative maintenance inspections involve working inside the UPS which contains hazardous AC and DC voltages and should only be performed by authorised service personnel.

During a preventative maintenance inspection the field service engineer will check:

- Site/environment conditions
- Integrity of electrical installation
- Cooling airflow
- Rectifier operation and calibration
- Inverter operation and calibration
- Static switch operation
- Battery status
- Load characteristics
- Integrity of alarm and monitoring systems
- Operation of all installed optional equipment

Preventative maintenance inspections form an integral part of all Extended Warranty Agreements (maintenance contracts) offered by Uninterruptible Power Supplies Ltd.

5.5 Battery testing

The battery test takes approximately 3 minutes and should be performed only if:

- There are no alarm conditions
- The battery is fully charged
- The mains input supply is present

Battery testing can be performed from the Operator Control Panel and carried out independently of the operating mode ('on-line' or 'on-bypass') and whether or not the load is connected.

5.6 Battery maintenance

The UPS batteries should be replaced under the following conditions:

- If the battery service life (3~5 years at 25°C ambient temperature) has been exceeded
- When the discharging time is less than 50% of specified after full charged

When replacing the batteries, the complete battery string should be replaced with the same number and type of batteries. Individual batteries should not be replaced.

If the UPS is not used for a period of time the batteries should be charged at least every 4-6 months. When healthy, the batteries will charge to 80% in approximately 10 hours, however it is recommended that the batteries are charged for 48 hours after long term storage.

5.7 Battery disposal and recycling

Batteries contain dangerous substances that will harm the environment if carelessly discarded and should be disposed of in accordance with local recycling recommendations

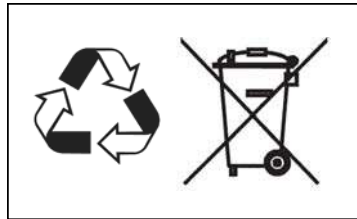

6 Troubleshooting

IMPORTANT NOTE

Certain alarm conditions may 'latch-on' even after the cause of the alarm is no longer present. For example, if there is a brief mains failure during unattended operation the MAINS FAIL alarm will activate and it may still indicate a fault condition even after the mains supply has returned to normal. Similarly, a LOAD ON BYPASS alarm might have been caused by an inverter overload

If any alarm appears, the first action to take is to attempt to RESET it.

If the alarm indication resets then it was probably caused by a transient condition; the UPS has responded correctly and no further action is required. Investigative action is necessary if it is not possible to reset the alarm, or if the alarm is repetitive, which may require assistance from the UPS Limited Service Department.

6.1 Contacting Service

Please collect the following information before calling the After-Sales Service Department:

- UPS model number and serial number
- Date on which the problem occurred
- LCD/LED display information, buzzer alarm status
- Mains power condition, load type and capacity, environment temperature, ventilation condition
- Information on external batteries (battery capacity, quantity)

Uninterruptible Power Supplies Limited has a service department dedicated to providing routine maintenance and emergency service cover for your UPS. If you have any queries regarding your UPS please contact us.

Uninterruptible Power Supplies Ltd. Woodgate Bartley Wood Business Park Hook Hampshire RG27 9XA	
Tel:	01256 386700 0800 731 3269 (24 Hr.)
Fax:	01256 386701
Email:	service@upspower.co.uk

We recommend that your UPS is protected by an Extended Warranty Agreement. These agreements assist us in caring for your UPS correctly, ensuring that it is well maintained and attended to promptly should any problems occur.

6.2 Fault identification and rectification

6.2.1 Troubleshooting without an error message

Display	Possible Cause	Remedy
No indication on LCD display. No warning tone even though system is connected to mains power supply.	No input voltage	Check the building wiring and input cable. Check that the external Input/bypass Isolator is closed.
Bypass LED ON even if the power supply is available.	Inverter not switched on	Press the POWER-ON key to turn on UPS and switch to 'on-line' mode.
Battery LED ON and audible alarm sounding	Input voltage and/or frequency out of tolerance	Check that the external Input/bypass Isolator is closed Check availability of input power source. Check the building wiring and input cable.
Emergency supply period shorter than nominal value	Batteries not fully charged or defective	Charge the batteries for at least 12 hours and then check capacity.

6.2.2 Troubleshooting based on error message

Display	Possible Cause	Remedy
Inv Overload Failure Alarm code:42	Overload.	Check the loads / remove non-critical loads. Check if some loads have failures.
Byp Overload Failure Alarm code:43	Overload.	Check the loads / remove non-critical loads. Check if some loads have failures.
Output short-circuit Alarm code:31	Short circuited output.	Remove all the loads. Turn off the UPS. Check if UPS output and loads are short-circuited. Ensure short circuit is removed before turning on the system again.
Heat sink Over Temperature Fault Alarm code:81	Inside temperature of UPS is too high.	Ensure the UPS is not overloaded, the air vents are not blocked and the ambient temperature is not too high. Wait for 10 minutes for the UPS to cool down before turning it on again. If failed, contact the service centre.
DC BUS over-voltage Alarm code:21	UPS internal fault.	Contact UPS supplier.
DC BUS under-voltage Alarm code:22	UPS internal fault.	Contact UPS supplier.
DC BUS unbalanced Alarm code:23	UPS internal fault.	Contact UPS supplier.
DC BUS softstart failure Alarm code:25	UPS internal fault	Contact UPS supplier.
INV over-voltage Alarm code:32	UPS internal fault.	Contact UPS supplier.

Display	Possible Cause	Remedy
INV under-voltage Alarm code:33	UPS internal fault.	Contact UPS supplier.
INV under-voltage Alarm code:33	UPS internal fault.	Contact UPS supplier.

7 Options

7.1 Back-feed protection

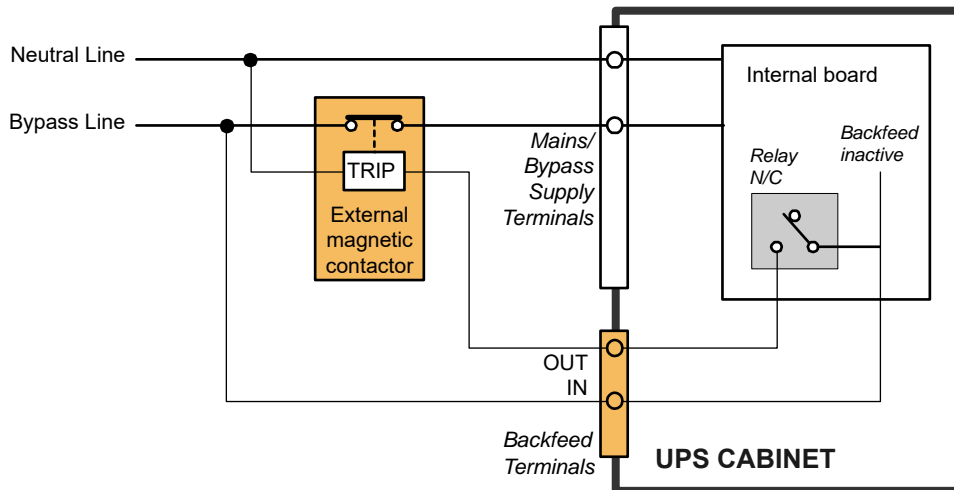

Figure 7.1 Backfeed protection option

An external isolation contactor can be fitted in the UPS bypass supply line as shown in Figure 7.1 to protect the UPS against back-feeding in the event of a critical static switch failure.

The external contactor magnetic 'trip' coil is connected to the backfeed contactor control terminals located behind a small cover on the back of the UPS.

An AC contactor rated at 100A minimum should be used – for example a three phase contactor of 3x 40A rating with the three poles wired in parallel. The trip coil should be rated according to bypass supply.

7.2 Emergency Power-OFF (EPO)



Figure 7.2 Emergency Power OFF

An external Emergency Power OFF (EPO) circuit can be connected to the UPS to enable it to be shut down remotely in an emergency situation. By default the external EPO circuit requires a normally closed contact which shuts down the UPS when opened. A link must be fitted to the EPO connector located on the back of the UPS if the EPO facility is not used, as shown above in Figure 7.2.



Key Point: Although the EPO facility is normally (factory) set to be a normally-closed contact, it can be reconfigured through the USB/RS232 port to be a normally-open contact. However, such a change must be carried out by an approved service engineer.

7.3 Computer communication options.



Figure 7.3 RS232 and USB Communication options

A USB and an RS232 port are provided to enable communication between the UPS and a remote computer/station. Only one communication port can be active at a time and the priority is given to the USB port.

When appropriate power management software, such as WAVEMON, is installed, the computer can continuously monitor the input mains voltage and UPS status, and display a message in response to any UPS system changes.

In the event of a power failure, and a predicted UPS shutdown due to low battery autonomy, the WAVEMON monitoring system will save the existing load data before initiating a shutdown of the load equipment.

7.3.1 USB Port

To establish communication between the UPS and a computer, connect the USB cable that is supplied with the UPS between the UPS USB port and the USB port on the computer. The USB port is compliant with USB 1.1 protocol.

7.3.2 RS232 Port. RS232 and USB Communication options

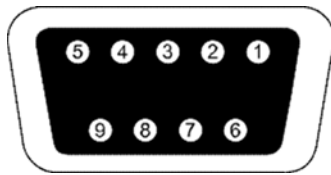

Pin	Signal	Description	I/O
2	TXD	Transmit to external device	Output
3	RXD	Receive from external device	Input
5	GND	Ground (tied to chassis)	Input

Figure 7.4 RS232 Pin assignment

To establish a communication link between the UPS and a computer, connect one end of the serial communication cable that is supplied with the UPS to the RS-232 port on the UPS and the other end to the RS-232 port on a computer. The cable pins for the RS-232 communication port are described in Figure 7.4.

7.4 Serial Network Management (SNMP) card

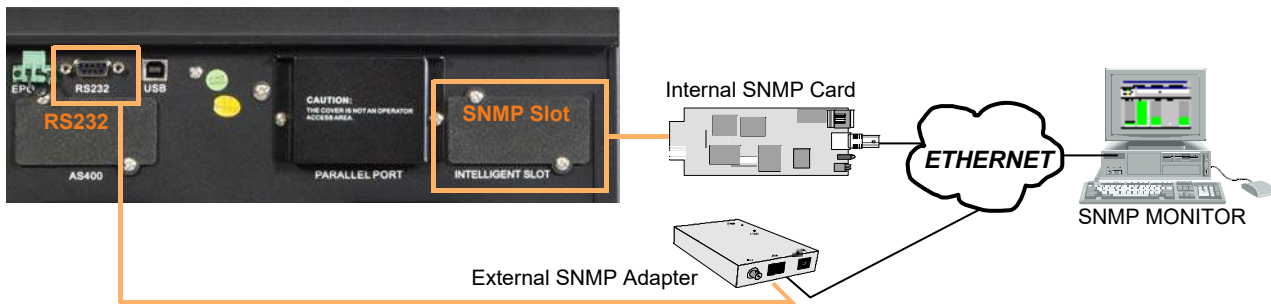

Figure 7.5 SNMP connection options

Simple Network Management Protocol (SNMP) is a world-wide, standardised communication protocol that can be used to monitor any network-connected device via a simple control language and display the results in an application running within a standard web browser. The SNMP adaptor requires a PC with terminal connections, and least one Ethernet network connection.

The optional SNMP card fits into the 'Intelligent Slot' located on the back of the PowerWave PW3000/TP, as shown in Figure 7.5. Alternatively, SNMP connectivity can be implemented using an external SNMP adapter connected to the UPS RS232 output, as shown.

An SNMP/Ethernet adapter contains an RJ-45 connector which allows it to be connected to the network using a standard network cable. Once connected, the UPS-Management software agent, which is already installed in the SNMP adapter, then monitors the UPS operating parameters and outputs its data in SNMP format to the connected network. In a multi-module UPS system the SNMP interface can communicate 'system-wide' data or data for an individual UPS module.

SNMP card installation

The UPS does not have to be shutdown before installing a communication card:

1. Remove the two screws that protect the Intelligent Slot of the UPS.
2. Insert the SNMP card into the slot.
3. Secure the SNMP card in position using the screws removed in step 1.

Note: For more information on the SNMP Cards, see the SNMP User's Manual.

7.5 AS400 Interface card



Figure 7.6 AS400 Pin assignment

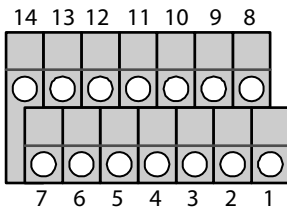

The optional AS400 Interface card fits into the 'AS400' slot located on the back of the PowerWave PW3000/TP. The card provides five UPS status/alarm outputs and monitors three switched inputs via two 7-way Phoenix terminal blocks.

The card also contains an RS232 interface which can be used to configure the card's operation. Using some basic terminal communication software, such as Hyper terminal, it is possible to change both the function and polarity of the relay; for example, to select an individual switch segment to be Normally-Open or Normally-Closed, and immediate/delayed operation. Detailed operating instructions are included in the option package.

RS232 Interface

The inbuilt RS232 interface is accessed via an RJ45 connector located adjacent to the I/O terminal blocks. An RJ45 to 9-way D-Type adapter cable is provided with the equipment to allow connection to a computer's serial port.



WARNING: The RJ45 connector must only be used for RS232 applications. If it is connected to a network switch it may damage the UPS and/or network equipment.

AS400 Alarm outputs

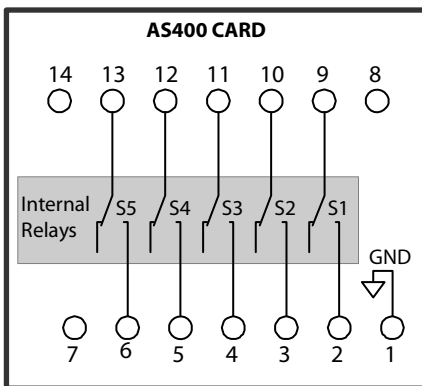

The switched outputs are configured as 5 segments:

Segment 1	Terminal 9-2	Utility (mains) Failure
Segment 2	Terminal 10-3	Battery Low
Segment 3	Terminal 11-4	General Alarm
Segment 4	Terminal 12-5	Bypass Status
Segment 5	Terminal 13-6	Summary Alarm

The card's internal volt-free contacts are rated at 250VAC/8A, 30VDC/8A, 110VDC/300mA, 220VDC/120A, and the terminal block accommodates cables in the range 0.5 mm² to 1.5 mm².

AS400 Inputs

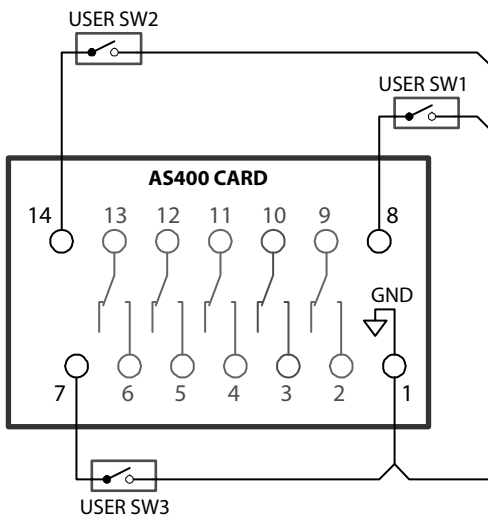

The switched inputs are configured as 3 segments:

Segment 6	Terminal 8-1	User Configurable – Battery Mode Shutdown (Default) – Any Mode Shutdown – Emergency Power Off – Remote ON/OFF
Segment 7	Terminal 14-1	Reserved for UPS ON Signal (Switch On UPS)
Segment 8	Terminal 7-1	Reserved for UPS OFF Signal (Switch OFF UPS)

AS400 Interface Card installation

The AS400 Interface Card should be installed and configured by the commissioning engineer.

7.6 UPS Monitoring and automated control software

7.6.1 The importance of UPS management

The utility supply is inevitably unreliable every now and then; and assuring continuous power to all the facilities connected to it can be a difficult task. The situation is further complicated if worldwide systems are managed via a Local Area Network (LAN) or Wide Area Network (WAN). However, by using the PowerWave PW3000/TP UPS system in conjunction with purpose-designed network management tools, a systems administrator can take measures to back-up data and prevent system errors or data loss even in the event of a relatively long utility supply outage. In the case of an abnormal utility supply, suitable UPS management software will also enable a system administrator to monitor all concerned networks from a central point and identify bottlenecks at an early stage.

Despite extensive system monitoring, serious damage can still occur if an administrator fails to intervene in a timely manner, so it is important that the installed UPS software will react automatically in such a case and shut down the supplied system in a safe and controlled manner.

Uninterruptible Power Supplies Ltd considers it important to have a complete solution for its UPS systems, and offers its customers a number of remote control and monitoring tools to provide optimum protection.

SNMP monitoring/control software

Working in conjunction with the adapter card described above, Uninterruptible Power Supplies Ltd offer suitable monitoring and control software with SNMP functionality for NetWare, OS/2 and all Windows NT systems on INTEL and ALPHA network platforms.

8

Specifications

	10kVA	10kVA +5 min battery	10kVA +16 min battery	20kVA	20kVA +5 min battery
GENERAL					
Output power factor	0.9			0.9	
Rated output power (@ pf=0.8)	10 kVA			20 kVA	
Rated output power (@ pf=1.0)	9 kW			18 kW	
Weight	56 kg	117 kg	177 kg	66 kg	187 kg
Dimensions WxHxD	350x890x712	350x890x712	350x890x712	350x890x712	350x890x712
Colour	Pantone Process Black C				
Topology	True on-line double conversion				
INPUT CHARACTERISTICS					
Nominal input voltage	1ph + N: 220 / 230 / 240 VAC			3ph + N: 380 / 400 / 415 VAC	
Input voltage tolerance	1ph + N: 110-276 Vac			3ph + N: 190-486 Vac	
Power factor	≥0.99				
Input power at rated output (no batt charging)	9.68 kW			19.35 kW	
1Ph Input current at rated output (no batt charging)	44.4A / 42.5A / 40.7A (@ 220V / 230V / 240V)			88.9A / 85.0A / 81.5A (@ 220V / 230V / 240V)	
3Ph Input current at rated output (no batt charging)	14.9A / 14.1A / 13.6A (@ 380V / 400V / 415V)			29.7A / 28.2A / 27.2A (@ 380V / 400V / 415V)	
Input power at rated output (max batt charging)	10.99 kW			20.43 kW	
1Ph Input current at rated output (max batt charging)	50.5A / 48.3A / 46.2A (@ 220V / 230V / 240V)			94.9A / 90.8A / 87.0A (@ 220V / 230V / 240V)	
3Ph Input current at rated output (max batt charging)	16.9A / 16.0A / 15.4A (@ 380V / 400V / 415V)			31.7A / 30.1A / 29.0A (@ 380V / 400V / 415V)	
Input current THD	<5% linear load, <7% non-linear load				
Frequency range	45-55 Hz for 50 Hz system / 55-65 Hz for 60 Hz system				
Frequency tolerance	±2%				

NOTE: Technical specifications are subject to change without notice

	10kVA	10kVA +5 min battery	10kVA +16 min battery	20kVA	20kVA +5 min battery
OUTPUT CHARACTERISTICS					
Rated output voltage	220 / 230 / 240 Vac				
Voltage tolerance	±2%				
Voltage distortion	≤ 2% linear load, ≤ 5% non-linear load				
Overload capability (linear load)	5 minutes: 105%~110%; 1 minute: 110%~130%; 10 seconds: 130%~150%; 2 seconds >150%				
Nominal frequency	50 or 60 Hz ±0.1 Hz				
Crest factor	3:1				
EFFICIENCY (230V / 50Hz)					
100% Load	Up to 93%				
In ECO mode (HE mode)	Up to 97%				
BATTERY					
Inbuilt batteries	No	Yes	Yes	No	Yes
Number of batteries	–	1 x 24	2 x 24	–	2 x 24
Battery capacity	–	9 Ah	9 Ah	–	9 Ah
Charger current	4A	4A	4A	4A	4A
Recharge time	–	3h to 90%	8h to 90%	–	8h to 90%
AUTONOMY TIMES (MINS) (Half load / Full load)					
UPS Internal Batteries	–	16 / 5	41 / 16	–	16 / 5
UPS +1 Battery cabinet	41 / 16	59 / 28	92 / 42	16 / 5	42 / 16
UPS +2 Battery cabinet	92 / 42	118 / 49	150 / 60	42 / 16	60 / 27
UPS +3 Battery cabinet	150 / 60	180 / 80	213 / 90	60 / 27	90 / 42
UPS +4 Battery cabinet	213 / 90	245 / 103	246 / 132	90 / 42	118 / 53
ENVIRONMENTAL					
Protection rating	IP20				
Audible noise	55 dB Measured at 1 metre from the front of the UPS on 100% load and fully charged batteries.				
Storage temperature	-15°C to +60°C for UPS; 0°C to +35°C for battery				
Operating temperature	0°C to +40°C				
Relative humidity	0-95% (non condensing)				
Altitude (above sea level)	1000m without de-rating				
COMMUNICATIONS					
User interface	Menu-driven LCD display				
Communication card options	Network interface (SNMP card) Dry contact (AS400 card) USB / RS232 Computer interface				
STANDARDS					
Safety	IEC/EN62040-1				
EMC	IEC/EN62040				
ROHS	EN50581:2012				
Performance	IEC/EN62040-3				
Manufacturing	ISO 9001:2008, ISO 14001:2004				