

PowerWAVE 6000 (60–500 kVA)

User Manual



Uninterruptible Power Supplies Ltd has taken every precaution to produce an accurate, complete and easy to understand manual and will therefore assume no responsibility nor liability for direct, indirect or accidental personal or material damage due to any misinterpretation of or accidental mistakes in this manual.

© 2005 Uninterruptible Power Supplies Ltd

This manual may not be copied nor reproduced without written permission of Uninterruptible Power Supplies Ltd.

Table of contents

Safety 1

1.1	Description of symbols used in this manual	3-1
1.2	User precautions	3-1

Description 2

2.1	Introduction	4-2
2.1.1	Reliability and quality standards	4-2
2.1.2	Key features	4-2
2.2	PowerWAVE 6000 Model range	4-3
2.2.1	Single/Multi system configurations	4-3
2.3	PowerWAVE 6000 UPS module functional description	4-3
2.3.1	PowerWAVE 6000 UPS module block diagram	4-4
2.3.2	UPS internal operating modes	4-4
2.3.3	System operating modes	4-6
2.3.4	Multi-cabinet parallel system concept	4-6
2.4	PowerWAVE 6000 User Controls	4-8
2.4.1	Power isolators	4-8
2.4.2	UPS Control Panels	4-9
2.5	LCD Control panel	4-9
2.5.1	Module mimic LED indicators	4-9
2.5.2	Operator keys	4-10
2.5.3	Power Management Display (PMD)	4-11
2.6	TFT Control panel	4-15
2.6.1	Display header bar	4-15
2.6.2	Mimic diagram screen	4-16
2.6.3	Home screen	4-17
2.7	Warranty	4-19
2.7.1	Extended warranty	4-19
2.7.2	Additional service/maintenance support	4-19
2.8	Extended Service enquiry form	4-20

Installation 21

3.1	Introduction	5-21
3.2	Taking receipt of the UPS	5-21
3.2.1	Site transportation	5-21
3.3	Unpacking	5-22
3.4	Storage	5-22
3.5	Planning the installation (site considerations)	5-23
3.5.1	Clearances	5-23
3.6	Planning the installation (cabling considerations)	5-24
3.6.1	General requirements	5-24
3.6.2	Cable and fuse sizing	5-25
3.6.3	Power cable terminations	5-28
3.6.4	Power cabling in a parallel system	5-30

3.7	UPS Cabling procedure (60-300kVA models)	5-31
3.7.1	Connecting the input cables	5-31
3.7.2	Connecting the UPS output cables	5-32
3.8	UPS Cabling procedure (400/500kVA models with bottom cable entry)	5-36
3.8.1	Introduction	5-36
3.8.2	Cabling procedure	5-37
3.9	UPS Cabling procedure (400/500kVA models with Top Cable Entry option)	5-40
3.9.1	Introduction	5-40
3.9.2	Installation notes	5-40
3.9.3	TCE Enclosure mechanical installation	5-41
3.9.4	TCE Enclosure cabling	5-41
3.10	Single/Dual feed conversion for 400kVA/500kVA models	5-45
3.11	Battery connections	5-46
3.11.1	'Sidecar' battery enclosure (60-100kVA)	5-46
3.11.2	Remote battery enclosure	5-47
3.11.3	Connecting the batteries	5-47
3.12	Multi-module control cabling and configuration	5-47
3.12.1	Connecting the parallel communication bus cables	5-47
3.12.2	Configuration DIP switch selection	5-48
3.12.3	Module communications interface facilities	5-49

Operating Instructions with LCD Control Panel 50

4.1	Introduction	6-50
4.1.1	Operating procedure summary	6-50
4.2	Initial system power-up and functional testing	6-51
4.3	System shutdown to maintenance bypass	6-54
4.4	System start-up from maintenance bypass	6-55
4.5	Individual module stop/start procedure	6-56
4.5.1	Single module system and capacity parallel module system	6-56
4.5.2	Redundant parallel module system	6-58
4.5.3	Complete system shutdown	6-59

Operating Instructions with TFT Control Panel 61

5.1	Introduction	7-61
5.1.1	Operating procedure summary	7-61
5.2	Single module initial system power-up and functional testing	7-62
5.3	Parallel system power-up and functional testing	7-64
5.4	Turning OFF/ON the UPS output (load power)	7-68
5.4.1	Turning OFF the UPS output	7-68
5.4.2	Turning ON the UPS output	7-68
5.5	Load transfer from on-line to bypass (ECO) mode of operation	7-69
5.6	Load transfer from bypass (ECO) to on-line mode of operation	7-70
5.7	Load transfer to maintenance bypass	7-70
5.8	Complete system shutdown	7-71

Maintenance 72

6.1	Introduction	8-72
6.2	User responsibilities	8-72
6.3	Routine maintenance	8-72
6.4	Battery testing	8-73

Troubleshooting 74

7.1 Alarms	9-74
7.2 LCD Control panel	9-74
7.3 TFT Control panel	9-74
7.4 Troubleshooting table	9-75
7.5 Contacting service	9-75

Options 76

8.1 Introduction	10-76
8.2 Serial RS232 Computer interface – USB & JD1 (Smart Port)	10-77
8.3 RS485 Interface for multidrop – JR1 (JR2 for 400-500kVA)	10-77
8.4 Dry ports customer interface (X1, X1, X3)	10-77
8.4.1 60-300kVA Model interface connections	10-78
8.4.2 400-500kVA Customer interface connections	10-79
8.4.3 Remote emergency stop option	10-80
8.4.4 Generator ON facilities	10-81
8.4.5 SNMP Card slots	10-81
8.4.6 WAVEMON Shutdown and monitoring software (instead of SNMP card)	10-82
8.5 PowerREPORTER™ management software	10-83
8.5.1 Functional description	10-83

Specifications 85

9.1 General specifications	11-85
9.2 60-300kVA Fuses & cables quick reference	11-92
9.3 400-500kVA Fuses & cables quick reference	11-93

1 Safety

1.1 Description of symbols used in this manual



WARNING: The warning symbol is used where there is danger of an electrical shock, equipment damage or personal-injury.



CAUTION: The caution symbol is used to highlight important information to avoid possible equipment malfunction or damage.

1.2 User precautions



WARNING: Keep this manual with the UPS for future reference.



WARNING: The UPS and peripheral equipment must be installed and commissioned by suitably qualified and trained personnel who are aware of the potential shock hazards.



WARNING: Do not attempt to install this UPS system until you are satisfied that ALL the safety instructions and hazard warnings contained in this manual are read and fully understood.



WARNING: High leakage current!
Ensure that the UPS has been correctly earthed before you connect the mains power supply!



WARNING: This UPS must not be started-up or put into use without having first been commissioned by a fully trained engineer authorised by the manufacturer.



WARNING: This UPS must be serviced by qualified personnel.
You run risk of exposure to dangerous voltages by opening or removing the UPS-covers! Uninterruptible Power Supplies Ltd will assume no responsibility nor liability due to incorrect operation or manipulation of the UPS.



WARNING: The PowerWAVE 6000 is a Class A UPS product (according to EN 62040-3). In a domestic environment the UPS may cause radio interference. In such an environment the user may be required to undertake additional measures.

2 Description

2.1 Introduction

Congratulations on your purchase of the PowerWAVE 6000 UPS.

Continuous power availability is essential in today’s dynamic IT and process-related work environments. It is equally important that any installed power protection system is sufficiently resilient and adaptable to handle any requirement changes brought about by the introduction of new server technologies, migration and centralization.

Such demands are well met by the PowerWAVE 6000 UPS system, which provides the foundation for continuous power availability of network-critical infrastructures both in enterprise data centres, where business continuity has paramount importance, and in process control environments, where manufacturing continuity is essential.

2.1.1 Reliability and quality standards

The PowerWAVE 6000 UPS is available over a model range of 60kVA to 500kVA and incorporates the latest technological developments in power engineering. Representing a completely new generation of high power three phase UPS systems, its advanced double conversion VFI (Voltage and Frequency Independent) topology responds fully to both the highest availability and environmentally friendly requirements compliant with IEC 62040-3 (VFI-SS-111) standards.

Uninterruptible Power Supplies Ltd. specialises in the installation and maintenance of Uninterruptible Power Systems; and this powerful UPS is just one example of our wide range of state-of-the-art power protection devices that will provide your critical equipment with a steady and reliable power supply for many years.

2.1.2 Key features

High reliability, upgrade ability, low operating costs and excellent electrical performance are just some of the highlights afforded by this innovative UPS solution. Other key features are shown below:

KEY FEATURES	
Compact size, small foot print	Space saving on expensive floor space
Flexible battery management	Advanced management of battery charging and preventive failure diagnostics avoids premature deterioration of battery life.
Best in class ac-ac efficiency, up to 96%	Energy-operational cost savings (TCO).
Low input power factor (near unity)	Cost savings during installation and the entire life cycle (TCO).
Blade-server-friendly power; full power from 0.9 lead to 0.9 lag	No de-rating required with leading power factor loads.
Very low input current distortion THDi THDi = < 3.5% @ 100% load	Gen-set power and installation cost saving

2.2 PowerWAVE 6000 Model range

The PowerWAVE 6000 UPS range includes 60, 80, 100, 120, 160, 200, 250, 300, 400 and 500kVA models.

Models in the 60-100kVA range are available in three cabinet sizes, two of which incorporate internal battery housing. Models rated greater than 100kVA require the batteries to be mounted in a separate battery enclosure or on a purpose-designed battery rack. A range of optional battery closures are available.

For a complete description of the various cabinets' weight and dimensions see Chapter 9 (Specifications).

2.2.1 Single/Multi system configurations

The PowerWAVE 6000 UPS can be configured to operate as a single, stand-alone UPS or as a multi-module parallel UPS system with up to ten UPS cabinets connected in parallel. A multi-module configuration is generally chosen either to increase a system's total power capacity or enhance the system's overall reliability by providing module redundancy.

Note: In this manual the terms 'multi-module system' and 'parallel system' are synonymous.

Parallel system operation

When operating as part of a parallel UPS system, it is critical that various control functions such as load sharing, frequency synchronisation and load transfer are observed by all the connected UPS modules. This is achieved in the PowerWAVE 6000 UPS system by connecting by a parallel control bus between the UPS modules which allows them to communicate with each other and carry out the necessary synchronous control operations.

Due to its Decentralised Parallel Architecture (DPA) design each PowerWAVE 6000 UPS can take the leadership role when operating in a multi-module system. This ensures the highest possible level of power availability and avoids a single point of failure that can exist in other, more traditional, parallel systems.

Parallel system expansion

Most data centres present a low initial power demand which increases as the data centre grows to its full capacity; and it is essential that any installed power protection system can be expanded to meet the growing demand without compromising the existing load. This situation is easily managed in a PowerWAVE 6000 multi-module installation which allows an additional module(s) to be connected to an existing parallel system without having to temporarily transfer the load to the raw by-pass mains supply. Thus the load receives UPS protected power at all times during the upgrade process – without interruption.



Key Point: All the UPS modules connected to a parallel system must be of the same power rating.

2.3 PowerWAVE 6000 UPS module functional description

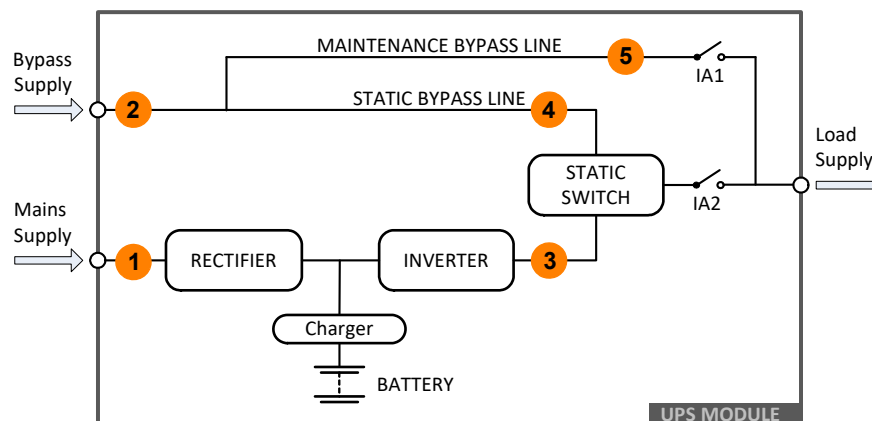

Figure 2.1 PowerWAVE 6000 UPS module block diagram

2.3.1 PowerWAVE 6000 UPS module block diagram

Figure 2.1 shows the power blocks contained within the PowerWAVE 6000 UPS module.

UPS Input supplies

The mains supply (1) is a three phase supply which is connected to the UPS rectifier. During normal operation this supply is rectified to provide a DC input to the inverter and battery charger. A separate mains supply (2) is shown connected to the static bypass in Figure 2.1; however in a standard UPS module the bypass supply terminals (2) are usually linked to the mains supply terminals (1) so the UPS effectively requires only one mains supply connection – see paragraph 3.6.2 for details concerning ‘single feed’ & ‘dual feed’ input configurations. The bypass supply is also connected to the static switch (4) and the maintenance bypass line (5).

UPS Output (load) supply

Figure 2.1 shows that the UPS output (load supply) can be provided through one of three power paths from within the UPS, depending on the UPS operating mode:

- From the inverter (3), via the static switch and isolator IA2.
- From the static bypass line (4) via the static switch and isolator IA2.
- From the maintenance bypass line (5) via the maintenance bypass isolator IA1.

The criteria for operating under each of these UPS modes is described below.

2.3.2 UPS internal operating modes

Load on Inverter

This is the normal operating mode and the only one that provides the load with continuously processed and backed-up power.

In this mode, the mains supply is converted to DC by the rectifier which then charges the battery and provides operating power for the inverter; which converts the rectifier output back into an AC supply that is suitable to provide the load power.

If the mains supply fails or strays outside a preset voltage range, the rectifier shuts down and the battery provides an alternative DC power source for the inverter; which continues to operate until the battery is discharged.

When operating in the ‘load on inverter’ mode the inverter output frequency is synchronised to the bypass supply provided the bypass supply frequency remains within preset limits. If the bypass supply fails altogether, the inverter frequency is controlled by a free-running oscillator that will maintain the output frequency at a constant 50/60Hz.

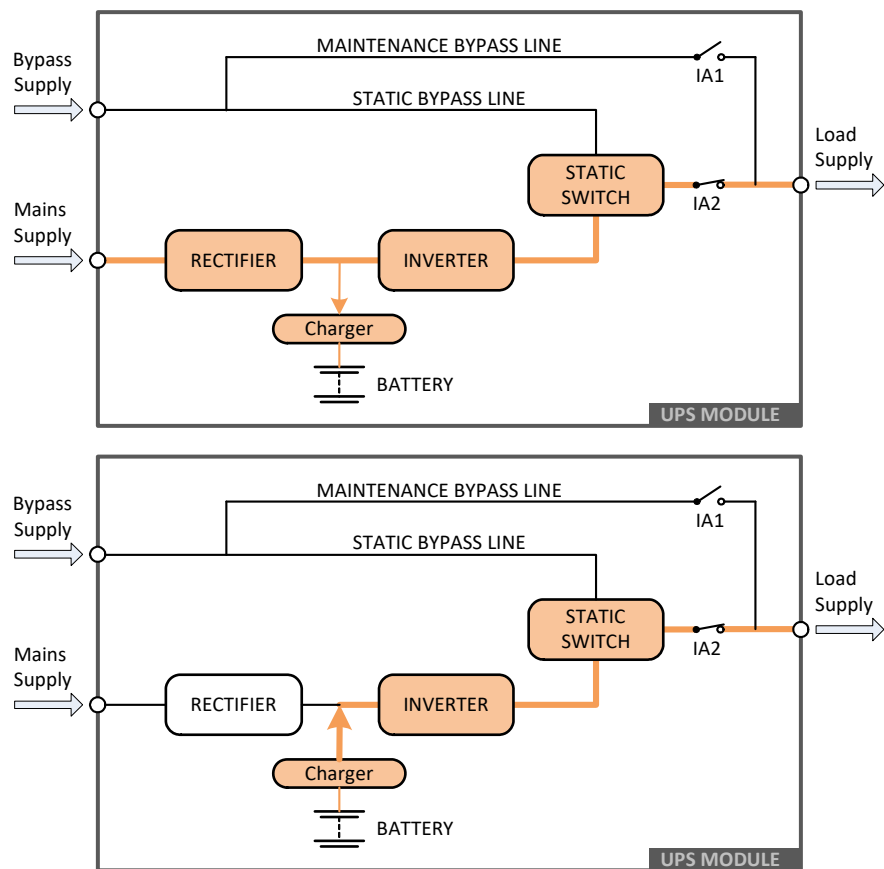

Figure 2.2 Load on inverter

2: Description

'On-battery' operation

Various alarms are generated as the battery discharges when the UPS is operating from battery power. This enables the operator to shut-down the load in an orderly manner if necessary (e.g. save data) before the battery reaches its end-of-discharge voltage and the UPS shuts down. Various options are available to automate the load shut-down process, as described in Chapter 8 of this manual (Options).

In practice the system design often incorporates a standby generator which starts-up automatically in the event of a mains supply failure and provides an alternative UPS input supply until the utility mains supply returns to normal. In this scenario the battery is only required to support the inverter (load) until the generator comes on-line and, as a modern generator can be automatically started very quickly, results in a relatively short battery discharge period – which helps in prolonging the battery life.

Load on-bypass

In the load 'on-bypass' mode the load supply is connected to the unprocessed static bypass line via the static switch.

When operating in this mode the rectifier, charger and inverter sections can be turned off entirely or remain running, and continue to provide battery charging.

Inverter/Bypass load transfer

As illustrated in the above diagrams, the load supply is connected to the inverter or static bypass line by means of the static switch. This is a solid state switch which is operated by the UPS microprocessor control system and allows the 'load on inverter' or 'load on bypass' operating modes to be selected either manually, via the UPS control panel, or automatically depending on various UPS operating conditions (see paragraph 2.3.3).

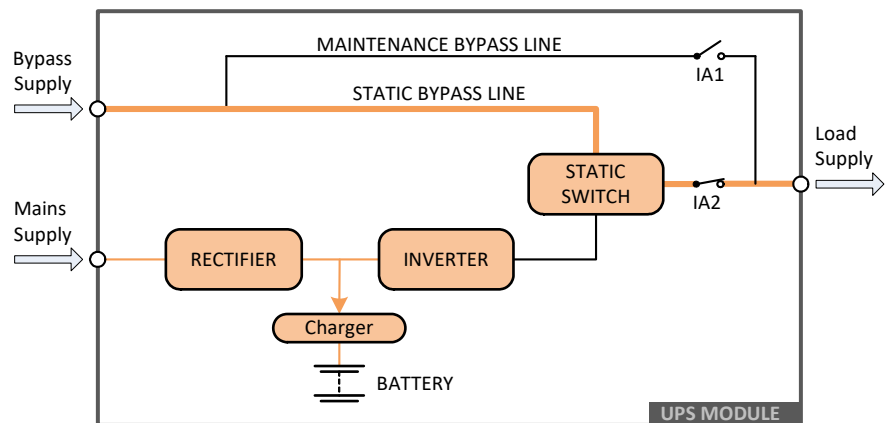

Figure 2.3 Load on bypass

Load on maintenance bypass

In this mode of operation the manually closed maintenance bypass switch (IA1) connects the load supply directly to the raw bypass supply. This facility can be used to keep the load supplied (albeit without any power protection) whilst allowing the remainder of the UPS to be shut down for service repair.

Note: Live voltages are still present on the UPS input and output power terminals when operating in the maintenance bypass mode.

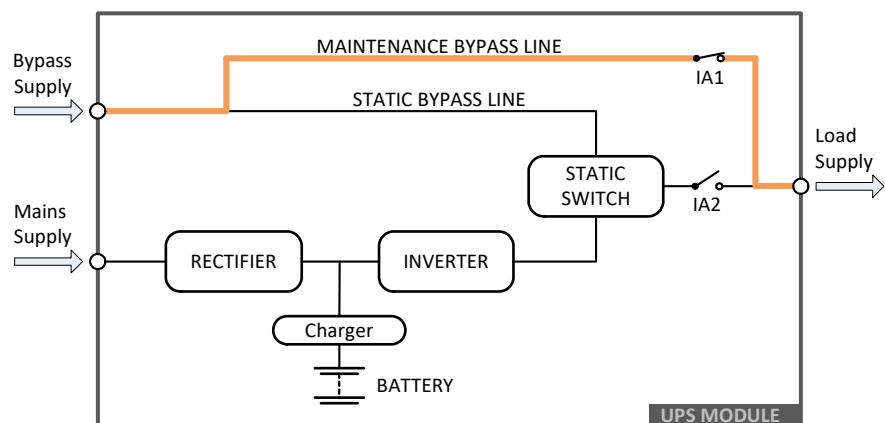

Figure 2.4 Load on maintenance bypass

To prevent possible inverter damage, it is important that the inverter output and maintenance bypass lines are never connected in parallel. Therefore when transferring from the 'load on inverter' mode to the 'load on maintenance bypass' mode it is important that the load is first transferred to the static bypass ('load on bypass' mode) before the maintenance bypass switch is closed.

Note: Always follow the operating instructions in Chapter 4 of this manual when starting or shutting down the UPS.

2.3.3 System operating modes

Paragraph 2.3.2 described the various UPS internal operating modes: but UPS systems are also categorised according to the way in which they operate at a 'system' level, and are typically described as being either an 'on-line', 'off-line' or 'line interactive' UPS system.

The PowerWAVE 6000 can be operated in all three of the above categories.

On-line operation

When used as an 'on-line' UPS the PowerWAVE 6000 module(s) is configured to normally operate in the 'load on inverter' mode.

In the unlikely event of an inverter fault, or during an overload, the UPS will transfer the load to the static bypass automatically and without interruption (transfer time = 0). If the transfer is due to an overload the system will transfer back to the 'load on inverter' mode if the overload clears and the inverter returns to normal operation.

Operating in the 'on-line' mode provides the highest degree of load protection, especially in the event of a mains disturbance or failure, and is always recommended if the critical load (e.g. computer system) will not tolerate even a very brief supply interruption.

Off-line / line interactive operation

When the PowerWAVE 6000 is used in an 'off-line' or 'line-interactive' mode the UPS module(s) normally operated in the 'load on bypass' mode, with the load being supplied from the static bypass supply. However the rectifier and battery charger are still powered up to maintain battery charging, and the inverter section is turned on and operating on standby.

In the event of a bypass supply error, or total failure, the load is automatically transferred to the inverter ('load on inverter') by the static switch within 3 to 5 milliseconds; and if the rectifier mains supply is missing when the transfer takes place the inverter will support the load operating from battery power, as described above. If the bypass supply returns to normal the load is transferred back to the static bypass and the inverter returns to its standby function.

This mode of operation is slightly more energy efficient than the 'on-line' mode due to the reduced rectifier/inverter losses during normal operation; and it is sometimes referred to as the "ECO" mode. However this mode is recommended only if the connected load equipment can tolerate power interruptions of 3 to 5 ms during the transfer period.



WARNING: The on-line mode must always be used for critical load protection.

2.3.4 Multi-cabinet parallel system concept

Up to ten PowerWAVE 6000 UPS cabinets can be connected in parallel for increased power capacity or redundancy operation. An example 3 module parallel system is shown in figure 2.5.

Note: If a PowerWAVE 6000 is purchased as a stand-alone UPS it will require a field upgrade in order to be connected to a parallel system at a later time.

A PowerWAVE 6000 UPS parallel system has a decentralised bypass architecture, in that each UPS module contains its own static bypass/static switch. This eliminates the need for a separate bypass cabinet (as required by some manufacturers' systems) and so avoids a potential single point of failure.

In a multi-module parallel system the topology and internal operation of each UPS module is identical to that described previously for a stand-alone module, except that the UPS control logic is subject to additional 'system level' control functions which are delivered via a parallel control bus connected between each module.

The parallel control bus performs many functions including:

- System-wide load transfer control.
- Inter-module (and bypass) frequency synchronisation.
- Load sharing.

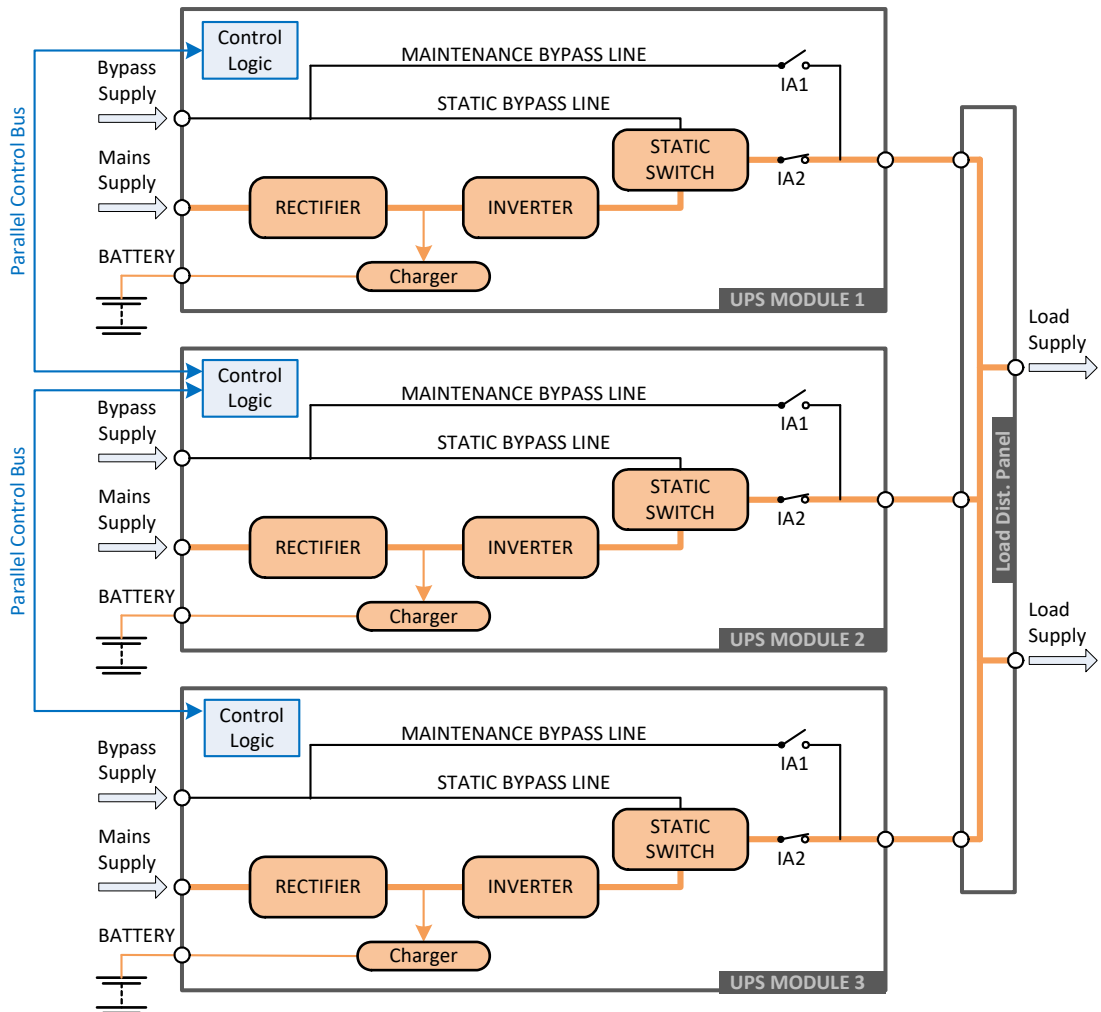

Figure 2.5 PowerWAVE 6000 UPS Parallel system

System-wide load transfer operation

All the modules that are connected to the load in a parallel system must be in the same internal mode of operation at all times – i.e. it is not permissible for one module to operate in the 'load on inverter' mode while the remaining modules are in the 'load on bypass' mode – such a situation would damage the UPS module(s).

In a parallel system therefore, if you activate the LOAD TO BYPASS command on any one module then all the modules will simultaneously switch to the 'load on bypass' mode. Conversely, when operating on bypass if you select the command LOAD TO INVERTER on any one module all the UPS modules will simultaneously transfer the load to their inverters – provided a sufficient number of modules are operating to satisfy any system redundancy requirements.

Inter-module frequency synchronisation and load sharing

Using sensing signals passed over the parallel control bus, each UPS module can compare its own frequency and output current with that of its neighbouring module. This allows the UPS control logic to carry out fine adjustments to each module to achieve balanced conditions.

The control logic always observes one of the modules as being the 'master' and the other module(s) as 'slaves'. However if the 'master' module goes faulty at any time the next module in the chain (a former 'slave') will immediately take over the role of master, and the former master module will turn off. Master/slave configuration is achieved through selector switches located in each cabinet and is set-up during commissioning (See paragraph 3.12.2).

Module redundancy

If a system is designed with module redundancy then it contains at least one UPS module more than the number required to provide the specified system full load power.

For example, if the system shown in figure 2.5 comprised 3x100kVA modules it could be employed as a redundant module system for a load of 200kVA. In this case under normal circumstances each module shares the load equally and supplies up to 66.6kVA at full load; but if one module fails, or is shut down, the two remaining modules can sustain the full rated load by each supplying 100kVA. The ability to lose one module yet still supply the full load with processed, backed-up power significantly increases the overall system reliability.

Two or more PowerWAVE 6000 UPS modules can be connected to a common battery to allow them to share the battery charging. However by employing a separate battery bank for each module, as illustrated in figure 2.5, it again avoids a potential single point of failure and effectively extends the system redundancy to include the batteries. We highly recommend the use of individual batteries for each module.

Isolating a module from the system

As explained immediately above, if a parallel system incorporates module redundancy a module can be isolated from the system for service/repair purposes without affecting the operation of the remaining modules or load.

Every UPS module is provided with a parallel (output) isolator (IA2) which can be used to isolate the module from the parallel load bus. When IA2 is open there is no load power being drawn from the module and it can be shut down in the normal way using the ON/OFF buttons on the UPS control panel; but in this case using these buttons will shut down the associated module only and will not cause the remaining modules to shutdown or transfer the load to bypass.



WARNING: When the UPS module is shut down its output terminals will be live even if the module's input mains and bypass supplies are isolated.

2.4 PowerWAVE 6000 User Controls

2.4.1 Power isolators

The PowerWAVE 6000 power isolators shown in Figure 2.6, and described below, are used during the UPS operating procedures when starting and shutting down the UPS. The location of the isolators is shown in the following illustration in Chapter 3.

- Figure 3.7 (60-100kVA)
- Figure 3.8 (120-200kVA)
- Figure 3.9 (250-300kVA)
- Figure 3.17 (400-500kVA)

F1/F2 Input/Bypass mains isolator

F1/F2 are fused isolators carrying 3 fuses which is replaced by 3-pole circuit breakers (IA3/IA4) in the 400-500kVA model.

IA1 Maintenance Bypass isolator

IA1 connects the UPS output directly to the raw bypass supply.

IA2 Parallel isolator

IA2 is used to disconnect the UPS from the output (load) terminals and can be used to isolate an individual module from the load in a multi-module parallel system.

F Batt

The battery isolation fuses (x3) are located within the UPS module in 60-100kVA models and externally in other models.

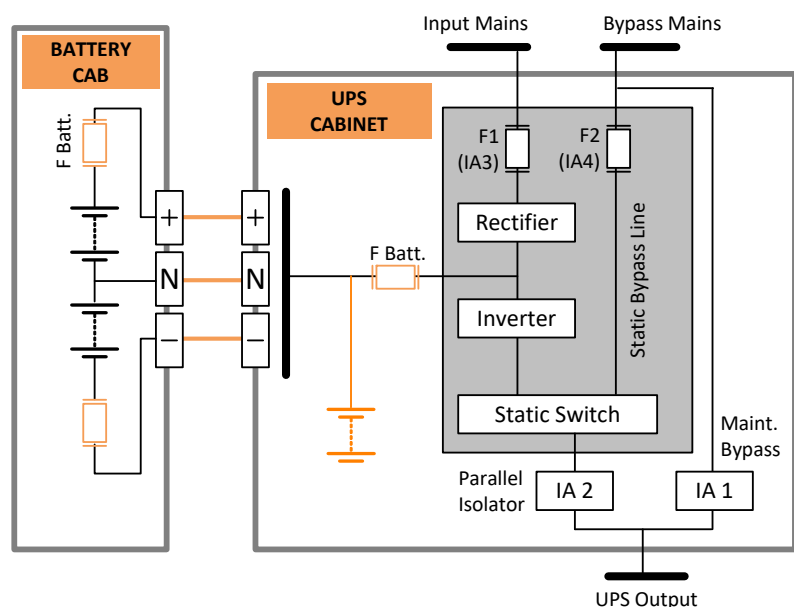

Figure 2.6 PowerWAVE 6000 power isolators

2.4.2 UPS Control Panels

A control panel located on the front of the cabinet provides the means for day-to-day UPS operation and performance monitoring. Two control panels are available; an LCD control panel is used on modules up to, and including, 300kVA, and a TFT touch screen control panel is used on 400kVA and 500kVA models.

Note: The TFT control panel is available as a fitted option on the lower rated models on request.

From the UPS control panel the operator can:

- Stop and start the UPS module.
- Transfer the UPS output (load) between the inverter and bypass.
- Monitor the UPS input/output voltage, current and frequency.
- Monitor the battery charge/discharge current and battery status.
- Interact with monitored alarm and warning messages.
- Configure the UPS operating parameters (service mode).
- Interrogate the UPS operating events and alarm history (service mode).
- Carry out diagnostic actions (service mode).

The LCD control panel is described in paragraph 2.5 and the TFT control panel in paragraph 2.6.

2.5 LCD Control panel

The LCD control panel is composed of three parts, shown below:

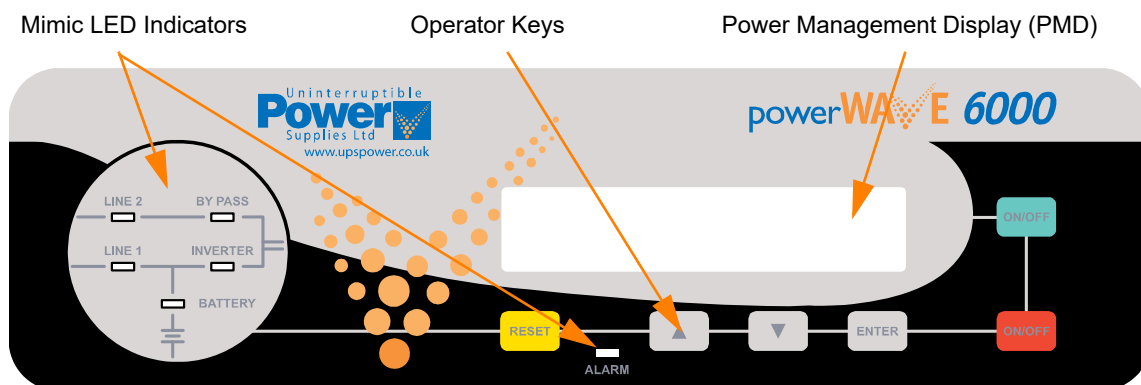

Figure 2.7 UPS Control panel

2.5.1 Module mimic LED indicators

The module mimic LEDs change colour between GREEN, RED and OFF to indicate the operational status of key UPS stages and thereby serve to show the active power path through the UPS.

- LINE 1 (rectifier) and LINE 2 (bypass) LEDs indicate the availability of the mains and bypass power supplies.
- INVERTER and BYPASS, illuminate green to indicate which of the two sources is providing the critical load power.
- BATTERY illuminates green when the battery is being charged and flashes when the battery is discharging and supplying the load – e.g. following a mains failure.
- ALARM provides a visual indication that a monitored internal or external alarm condition that requires attention. When activated, it is accompanied by an audible alarm.

LED Indication summary

Indicator	Indicator Status	Interpretation
LINE 1	GREEN RED	Mains available Mains not available
LINE 2	GREEN RED	Mains bypass OK Mains bypass not OK or not present
ALARM	OFF Flashing RED + buzzer RED	No alarm condition Alarm condition Alarm condition (has been reset)
INVERTER	GREEN RED OFF	Load on inverter Inverter fault Inverter not operating
BY-PASS	GREEN OFF	Load on bypass Bypass not operating
BATTERY	GREEN RED Flashing RED Flashing GREEN	Battery OK Battery fault or discharged Battery fuses blown On Battery

2.5.2 Operator keys

The operator keys allow the user to:

- Set operating parameters and adjustments via the menu driven LCD display.
- Start and stop the UPS and transfer the load between inverter and bypass.
- Select the UPS operating voltages, currents, frequencies and other values on the LCD display

Key function summary

KEYS	FUNCTION
ON/OFF ON/OFF	Used to switch-on or switch-off the UPS
UP (▲)	Scroll upwards through a displayed menu
DOWN (▼)	Scroll downwards through a displayed menu
RESET	Cancels the audible alarm. If the alarm condition was transient the ALARM LED will also extinguish, otherwise it will remain ON (red)
ENTER	Confirms (selects) a chosen menu item

ON/OFF Start-up and shutdown buttons

The UPS can be switched ON or OFF by simultaneously pressing both ON/OFF keys on the control panel. The requirement to press both buttons is to help avoid accidental operation.

During normal operation, pressing the two ON/OFF buttons simultaneously will immediately shutdown the UPS.

- In a single module installation this will disconnect the UPS output unless the load is first transferred to the maintenance bypass (see operating instructions).
- In a parallel module system the UPS module will shutdown and its output will be disconnected from the parallel load bus. However, the load may or may-not transfer to bypass depending on whether or not the number of remaining live modules satisfies the system's redundancy – i.e. if there are a sufficient number of modules remaining to support the system's load then the load will not be transferred.

To shut down all the modules in a parallel system you must press both ON/OFF buttons on every module.

2.5.3 Power Management Display (PMD)

The 2 x 20 character LCD Power management display simplifies communication with the UPS and also provides UPS monitoring information.

Status screens

DESCRIPTION	LCD-DISPLAY
1. Load is protected by UPS power supplied by inverter (normal operation).	LOAD PROTECTED P01
2. Load is not protected by UPS power –supplied by mains power (load on bypass).	LOAD NOT PROTECTED P01
3. Load supply interrupted. UPS has been switched off by “ON/OFF” buttons.	LOAD OFF SUPPLY FAILURE P01
4. The UPS/module is not supplying load. The output switch is open.	LOAD DISCONNECTED P01 PARALLEL SWITCH OPEN

On the right hand side of the LCD-Display there is a 3 digit indicator which shows a module’s position in a multi-module system. The maximum number of modules that can be used in a parallel system is 10.

- S Stands for **S**ingle module. The system consists only of one UPS cabinet.
- P01 Stands for **P**arallel system and 01 identifies the cabinet as the 1st module (**MASTER**) in the system.
- P02 Stands for **P**arallel system and 02 identifies the cabinet as the 2nd module (**SLAVE**) in the system. This number can range from 02 to 10 depending on the cabinet’s position in the parallel system.

Setting the module position in a single/multi-module chain

Note: The position of a module in a multi-module configuration is set by DIP Switch SW1-9, which is located on the and set by the commissioning engineer. This switch should not be touched by the operator:

Main menu screen

DESCRIPTION	LCD-DISPLAY
1. A log of the last 64 events is stored in the Power Management Display.	→ EVENT LOG MEASUREMENTS
2. Allows monitoring of voltages, power, frequencies, currents, autonomy etc.	→ MEASUREMENTS COMMANDS
3. Enables the commands “Load to inverter”, “Load to bypass” and “battery test” to be executed.	→ COMMANDS SET-UP DATA
4. Allows the UPS personalized information (such as serial number) to be entered.	→ SET-UP DATA SET-UP USER
5. Allows user to set up Date/Time, automatic battery test, etc.	→ SET-UP USER SET-UP SERVICE
6. Password-protected area for service engineer use only.	→ SET-UP SERVICE

Event log menu screen

DESCRIPTION	LCD-DISPLAY
1. Logging Control; a log of the last 64 events is stored in the Power Management Display.	01 05-10-08 14-38-56 LOAD TO INV.
2. Every stored event is identified with a sequential number and time stamp.	02 05-10-08 14-38-59 LOAD TO BYP.
3. By pressing ENTER the code of the event will be displayed.	03 05-10-08 14-39-14 LOAD OFF

Measurements menu screen

DESCRIPTION	LCD-DISPLAY
1. Battery Runtime.	BATT. RUN TIME (MIN) 00h 00mm
2. UPS-Output Frequency.	OUTPUT FREQUENCY (HZ) 50.00
3. Bypass Frequency.	BYPASS FREQUENCY (HZ) 50.00
4. Battery Voltage.	BATTERY VOLTAGE (V) +0.0 - 0.0
5. Battery Charger Current.	BATT. CHARGE CUR. (A) + 0.0 - 0.0
6. Battery Discharge Current.	DISCHARGE CURRENT (A) 00.00
7. Rectifier Input Voltage (all three phases).	RECTIFIER VOLTAGE (V) 000 000 000
8. Bypass Input Voltage (all three phases).	BYPASS VOLTAGE (V) 000 000 000
9. Output Voltage (all three phases).	OUTPUT VOLTAGE (V)0 000 000 000
10. Output Current (all three phases).	OUTPUT CURRENT (A)0 0.00 00.00 00.00
11. Active Output Power (all three phases).	ACTIVE POWER (KW) 00.00 00.00 00.00
12. Reactive Output Power (all three phases).	REACTIVE POWER (kVAR) 00.00 00.00 00.00
13. Apparent Output Power (all three phases).	APPARENT POWER (KVA) 00.00 00.00 00.00
14. Output Power (all three phases).	OUTPUT POWER (%) 00.00 00.00 00.00
15. Battery capacity.	BATT. CAPACITY (%) 00.00

Commands menu screen

DESCRIPTION	LCD-DISPLAY
1. Transfer Load to inverter.	→ LOAD TO INVERTER LOAD TO BYPASS
2. Transfer Load to bypass.	→ LOAD TO BYPASS PERFORM BATT. TEST
3. Battery Test.	→ PERFORM BATT. TEST

UPS Data menu screen

DESCRIPTION	LCD-DISPLAY		
1. These general UPS Data are installed at the manufacturing plant.	UPS SERIAL NUMBER nn-nnnnnn		
2. Manufacturing date.	DATE OF MANUFACTURE 15-03-09		
3. EPROM Version.	EPROM VERSION V-000		
4. Actual Date and Time.	<table style="width: 100%; border-collapse: collapse;"> <tr> <td style="width: 50%; border: none;"> DATE dd-mm-yyyy </td> <td style="width: 50%; border: none;"> TIME hh:mm:ss </td> </tr> </table>	DATE dd-mm-yyyy	TIME hh:mm:ss
DATE dd-mm-yyyy	TIME hh:mm:ss		

Set-up user menu screen

DESCRIPTION	LCD-DISPLAY
1. Set-up language.	→ SET LANGUAGE SET DATE AND TIME ENGLISH FRANCAIS DEUTCH DUTCH SPANISH POLISH PORTOGUESE
2. Set-up Date and Time.	→ SET-UP DATE/TIME SET-UP BATT. TEST DD-MM-YY HH-MM-SS
3. Set-up battery test.	→ SET-UP BATT. TEST SET-UP GEN-SET OPER. DAY OF MONTH (1-31) HOUR OF DAY (0-23) REPETITIVE (Y/N) 000
4. Set-up operation with Gen-Set.	→ SET-UP GEN-SET OPER. BATT. CHARGE LOCK (Y/N) BYPASS LOCK (Y/N)

Set-up service menu screen

DESCRIPTION	LCD-DISPLAY
1. This Menu is reserved for authorized service engineers. It is not to be used by end-users.	→ SET-UP SERVICE PASSWORD
2. Type in password.	→ PASSWORD*



Key Point: It is essential to enter the password.

From within the SET-UP SERVICE menu a service engineer can adjust the UPS voltages, frequencies, currents, power and autonomies, together with setting up:

- UPS Rated Power
- Module configuration S, P01, P02...
- Single (standard) or Dual input feed
- Frequency-converter, 50/60Hz and 60/50Hz
- Synchronisation window (2-4%)

2.6 TFT Control panel

The TFT control panel has a microprocessor-based touchscreen display which offers simple operation. When the UPS is energised the display runs through an initialisation process for several seconds and then automatically turns on, displaying the default mimic diagram screen. The screen's backlight turns off after three minutes of inactivity and turns back on when the screen is touched.

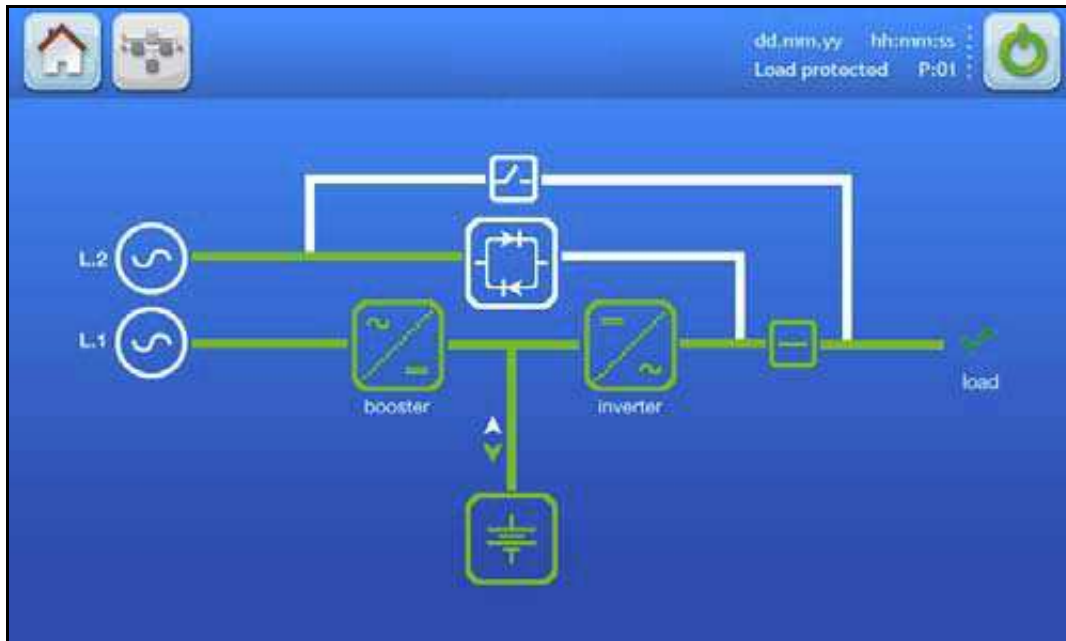

Figure 2.8 Mimic diagram screen (default)

2.6.1 Display header bar

A navigation and status bar is displayed in the header area of every screen.

A Home	Accesses the HOME screen.
B Mimic diagram	Accesses the MIMIC diagram screen.
C Warning	The warning symbol is only visible in the presence of an alarm or monitored events. Touching this icon will silence the audible alarm and open the EVENTS screen.
D Date	Current date indication. Set in the user menu and used to date-stamp the alarms/events log.
E Time	Current time indication. Set in the user menu and used to timestamp the alarms/events log.
F ON/OFF	Turns the UPS module ON/OFF. Requires a confirmation message to be accepted.
G UPS number	Each UPS module is given a sequential number in a parallel system. The number shown here is used to identify a particular module – e.g. P01 indicates the UPS number 01. In a single module installation this would indicate S01.
H Load Status	Load status: displays whether or not the load is protected, when the user is in the module navigation level.

Figure 2.9 Display header bar

2.6.2 Mimic diagram screen

The system level mimic diagram is the default screen and shows the power flow through the UPS module and indicates its operating status – in either single cabinet or multi-cabinet configuration. This screen can be accessed from any other screen by pressing the MIMIC icon in the display header bar.

The functional status of each block is identified by its line colour, as shown below in Figure 2.10, and the green connecting lines indicate the power flow in the system.



Figure 2.10 System level mimic display screen

Three meters are included on the mimic display screen to indicate the rectifier, inverter, bypass and load operating parameters. The displayed battery parameters include the battery temperature and remaining autonomy time. The meter display source is selected by touching the associated interactive block on the mimic display.

2.6.3 Home screen

The home screen is accessed by pressing the HOME icon on the display header bar on any screen (item A in Figure 2.9) and contains six icons that provide access to various control and set-up function screen.



Figure 2.11 Home display screen

Measures

UPS Measurements	Output Voltage (V)	Output Current (A)	Output Frequency (Hz)
	Output Power (%)	Active Power (kW)	Reactive Power (kVAr)
	Apparent Power (kVA)	Inverter Voltage (V)	Bypass Voltage (V)
	Bypass Frequency (Hz)	Rectifier Voltage (V)	Booster Temperature (°C)
	Inverter Temperature (°C)	Udc Gain +	Udc Gain -
Battery Measurements	Temperature (°C)	Discharge Current (A)	Charge Current (A)
	Voltage (V)	Run Time	Capacity(%)

Commands

Available commands	Load to inverter Deep battery test	Load to bypass Abort battery test	Battery test Perform alarm test
---------------------------	---------------------------------------	--------------------------------------	------------------------------------

UPS Data

UPS Data	Serial Number Hardware Version	Manufacturing Display Version	Firmware Version
-----------------	-----------------------------------	----------------------------------	------------------

User

UPS Settings	Language Battery Test	Date Repeat Test	Time Generator Operation
---------------------	--------------------------	---------------------	-----------------------------

Service

UPS Measurements	Output Voltage (V) Output Power (%) Active Power L3 (kW) Inverter Voltage (V) Rectifier Temperature (°C) Udc Gain -	Output Current (A) Active Power L1 (kW) Reactive Power (kVAr) Bypass Voltage (V) Inverter Temperature (°C)	Output Frequency (Hz) Active Power L2 (kW) Apparent Power (kVA) Bypass Frequency (Hz) Udc Gain +
-------------------------	--	--	--

Battery	Run Time Charge Current (A) I Battery Offset V Battery Offset - Blocks Minimum Threshold Stop Fast Charge	Voltage + (V) Discharge Current (A) Capacity(%) Autonomy (min) Cells Common Battery	Voltage - (V) Temperature (°C) V Battery Offset + Type Floating Voltage (V) Start Fast Charge
----------------	---	--	--

Offset	P Load Offset L1 Q Load Offset L1 I Inverter DC L1 Output DC L1 I Inverter Offset L1 I Bypass Offset L1 I Battery Offset	P Load Offset L2 Q Load Offset L2 I Inverter DC L2 Output DC L2 I Inverter Offset L2 I Bypass Offset L2 V Battery Offset + V	P Load Offset L3 Q Load Offset L3 I Inverter DC L3 Output DC L3 I Inverter Offset L3 I Bypass Offset L3 V Battery Offset -
---------------	--	--	--

UPS	Type Slot ID Parallel Inverter Voltage (V) Converter	Power Cosphi Frequency Rectifier Voltage (V) Separate Bypass	Unit Number System Sync Window General Alarm Delay
------------	--	--	---

UPS Data	Manufacturing Display Version	Firmware Version Dynamic Password	Hardware Version
-----------------	----------------------------------	--------------------------------------	------------------

Commands	Clear Alarms Default Config.	Service Mode	Standby Mode
-----------------	---------------------------------	--------------	--------------

Tests	Inverter Voltage	Open K Bypass	Close K Bypass
--------------	------------------	---------------	----------------

2.7 Warranty

The PowerWAVE 6000 UPS is supplied with a limited warranty that the UPS and its component parts are free from defects in materials and workmanship for a period of one year from the date of original commissioning or fifteen months from the date of original delivery, whichever is the sooner. This warranty is the only warranty given and no other warranty, express or implied, is provided.

This warranty is invalidated if the UPS is put into use without having first been commissioned by a fully trained and authorised engineer. This warranty does not apply to any losses or damages caused by misuse, abuse, negligence, neglect, unauthorised repair or modification, incorrect installation, inappropriate environment, accident, act of God or inappropriate application.

If the UPS fails to conform to the above within the warranty period then Uninterruptible Power Supplies Ltd. will at its sole option repair or replace the UPS. All repaired or replaced parts will remain the property of Uninterruptible Power Supplies Ltd.

As a general policy, Uninterruptible Power Supplies Ltd. does not recommend the use of its products in:

- life support applications where failure or malfunction of the product can be reasonably expected to cause failure of the life support device, or to significantly affect it's safety or effectiveness
- applications concerned with direct patient care

Uninterruptible Power Supplies Ltd. will not knowingly sell its products for use in such applications unless it receives in writing assurances satisfactory to Uninterruptible Power Supplies Ltd. that:

- the risks of injury or damage have been minimized
- the customer assumes all such risks
- the liability of Uninterruptible Power Supplies Ltd. is adequately protected under the circumstances



CAUTION: *The UPS may contain batteries that must be re-charged for a minimum of 24 hours every six months to prevent deep-discharging. Batteries that have been deep-discharged, for whatever reason, are not covered by the warranty.*

2.7.1 Extended warranty

The standard warranty may be enhanced by protecting the UPS with an extended warranty agreement (maintenance contract). An extended warranty agreement enhances the standard warranty by providing the following:

- regular preventative maintenance inspections.
- guaranteed speed of response to operational problems.
- 24 hour telephone support.
- fully comprehensive cover (excluding batteries and capacitors).

Contact the Service Support Hotline on 0800 731 3269 for further details.

2.7.2 Additional service/maintenance support

In addition to providing support for the PowerWAVE 6000 UPS, Uninterruptible Power Supplies Ltd. can provide maintenance and support on a wide range of different UPS products.

If you are interested in an extended warranty for your PowerWAVE 6000 UPS, or for any other UPS products you may have, please complete the following enquiry form and return or FAX it to:

Uninterruptible Power Supplies Ltd. Woodgate Bartley Wood Business Park Hook Hampshire RG27 9XA	Tel: 01256 386700 0800 731 3269 (24 Hr.) Fax: 01256 386701 Email: service@upspower.co.uk
--	---

2.8 Extended Service enquiry form

Fax to: 01256 386701

www.upspower.co.uk

Uninterruptible Power Supplies Ltd.
Woodgate
Bartley Wood Business Park
Hook
Hampshire
RG27 9XA

Tel: 01256 386700

Name:

Job Title:

Company:

Address:

.....

.....

.....

Post Code:

Tel.

Fax.

E-mail

Please contact me to discuss:

- Extended Warranty options for my PowerWAVE 6000 UPS
- Extended warranty options for my UPS System as below:
 - Manufacturer:.....
 - Model N°:.....
 - Rating kVA:.....
- Replacement Batteries.....
- Other(please specify)

Thank you for your enquiry, which will receive our prompt attention.
If you need to contact us immediately call free on,
Freefone 0800 731 3269
or E-mail us on service@upspower.co.uk
www.upspower.co.uk

3 Installation

3.1 Introduction

This chapter contains essential information concerning the unpacking, positioning, installing and cabling of the PowerWAVE 6000 UPS.



WARNING: All cabling operations must be supervised by an authorised electrician or other suitably qualified person. All installation and operating procedures must be carried out in strict accordance with the instructions contained in this manual. Uninterruptible Power Supplies Ltd. will take no responsibility for any personal injury or material damage caused by the incorrect installation, cabling or operation of this product.



WARNING: Once the UPS equipment is installed it must be commissioned by an engineer approved by Uninterruptible Power Supplies Ltd. before it is powered-up. Uninterruptible Power Supplies Ltd. will take no responsibility for any personal injury or material damage caused by the application of electrical power to this equipment before it has been fully commissioned.

3.2 Taking receipt of the UPS

The UPS cabinet and accessories are delivered on purpose designed pallets that are easy to off load and move using a forklift or suitable pallet jack.



CAUTION: Observe the following precautions when off-loading and moving the UPS:

- Always keep the packages in an upright position.
- Do not drop the equipment.
- Due to the high-energy batteries involved and heavy weight, do not stack the pallets.

The packing container protects the UPS from mechanical and environmental damage during transit. This protection is further increased by wrapping the PowerWAVE 6000 UPS with a plastic sheet.

Upon receiving the UPS you should carefully examine the packing container for any sign of physical damage. The external 'Tip&Tel' ("FRAGILE" and "ARROW") indicator should be intact if the equipment has been correctly transported in an upright position. If the packaging has been ruptured in transit, or if the 'Tip&Tel' indicator is suspect, inform both the carrier and Uninterruptible Power Supplies Ltd. immediately.



CAUTION: Claims for visible shipping damage must be notified to the carrier immediately on receipt. Other shipping damage claims must be filed immediately when found and the carrier must be informed within a maximum of 7 days following receipt of the equipment. If shipping damage is discovered you must store all packing materials for further investigation.

Ensure that the received UPS equipment corresponds to the description indicated in the delivery note.

3.2.1 Site transportation

Please observe the following precautions when you transport the UPS equipment from the off loading site to its intended installation (or storage) location.



CAUTION: Transportation:

- When transporting the equipment, use the front and rear shipping brackets to secure the cabinet to help prevent the UPS from toppling over.
- Do not at any time tilt the cabinet by more than 10° from vertical.



CAUTION: Potential dangers:

- If the UPS/battery cabinet is tilted by more than 10° it could cause internal damage. If tilting occurs do not connect the UPS to the mains electrical supply.
- The weight of the UPS/battery equipment can cause serious personal injury and/or structural damage to the surrounding area if dropped in transit. Always take extreme care when handling the equipment.



CAUTION: Storage:

- The UPS should be stored in the original packing and shipping carton.
- The recommended storage temperature for the UPS system and batteries is between +5°C and +40°C.
- The UPS system and the batteries must be protected from high humidity which should not exceed 90% RH (non-condensing).

3.3 Unpacking

1. If the cabinet is shipped inside a wooden case remove the screws at the base and sides of the case then carefully remove the case from the equipment pallet.
2. Cut the wrappers and remove the packing container by pulling it upwards.
3. Remove the plastic sheeting covering the UPS.
4. Remove any anchor bolts securing the cabinet to the pallet then remove the UPS from the pallet.
5. Retain the packaging materials for possible future shipment of the UPS.
6. Examine the UPS for signs of damage and notify your supplier immediately if any damage is found.
7. Check that the details on the UPS nameplate corresponds to the purchased material mentioned in the delivery note. The rating specifications can be found on a nameplate located inside the UPS door.

3.4 Storage

UPS Cabinet

If you plan to store the UPS cabinet prior to use it should be held in a clean, dry environment with a temperature between +5°C to +40°C and RH <90%. The UPS should be stored in the original packing and shipping carton. If the packing container is removed you must take measures to protect the UPS from dust.

Battery

The UPS uses sealed, maintenance-free batteries whose storage capacity depends on the ambient temperature. It is important not to store the batteries for longer than 6 months at 20°C, 3 months at 30°C, or 2 months at 35°C storage temperature without recharging them.

For longer term storage the batteries should be fully recharged every 6 months @20°C.



CAUTION: Sealed batteries must never be stored in a fully or partially discharged state.

Extreme temperature, under-charge, overcharge or over-discharge will destroy batteries!

- Charge the battery both before and after storing.
- Always store the batteries in a dry, clean, cool environment in their original packaging.
- If the packaging is removed protect the batteries from dust and humidity.

3.5 Planning the installation (site considerations)

A certain amount of pre-planning will help ensure a smooth and trouble-free installation of the UPS system. The following guidelines should be taken into account when planning a suitable UPS location and operating environment.

1. The route to the installation location must allow the equipment to be transported in an upright position.
2. The floor at the proposed installation site and en-route from the off-loading point must be able to safely take the weight of the UPS and battery equipment plus the fork lift during transit.
3. Locations with high ambient temperature, moisture or humidity must be avoided.
 - a) The installation site humidity should be <90% non-condensing.
 - b) The prescribed ambient temperature is +15°C to +25°C. An ambient temperature of 20°C is recommended to achieve a long battery life.
 - c) Any required cooling air flow must be available. The air entering the UPS must not exceed +40°C.
 - d) The air conditioning system must be able to provide a sufficient amount of cooling air to keep the room within the prescribed temperature range.
4. The following environmental conditions should also be considered:
 - a) Fire protection standards must be respected.
 - b) The location must be free of dust and corrosive or explosive gases.
 - c) The location must be vibration free.
 - d) If the UPS is located in bayed enclosures, partition walls must be installed.
 - e) The available space must permit the minimum cabinet clearances shown below.

3.5.1 Clearances

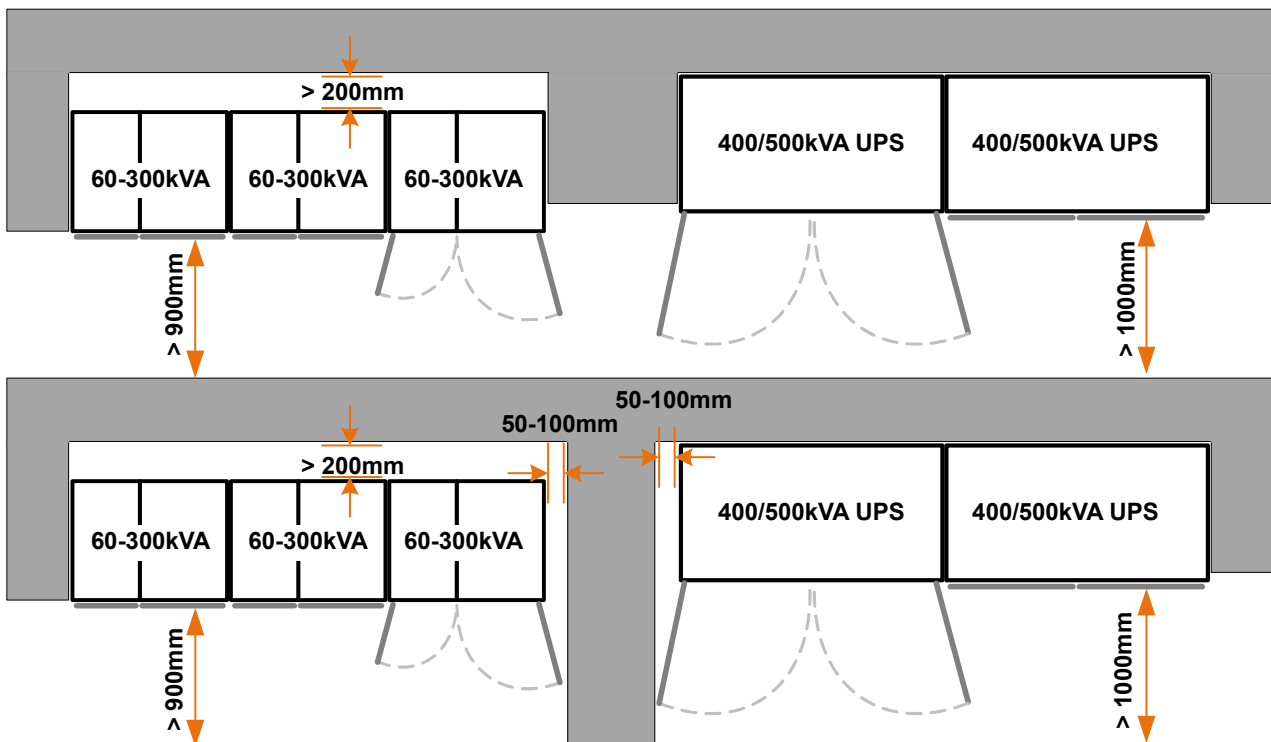

Figure 3.1 UPS Cabinet access space recommendations

All cables enter the UPS via the bottom of the cabinet therefore no service/installation access is required from the rear or sides of the cabinets.

A minimum of 900-1000mm clearance is required at the front of the cabinets for service access, and where possible this should be increased to allow safe passage in front of the UPS with the doors open.

In order to gain full access to some internal components it is necessary to open the doors by slightly more than 90°. If the cabinet is located adjacent to a partition or wall that extends beyond the front of the cabinet a clearance of 50-100mm should be provided between the cabinet and the partition to allow the doors to open adequately, as illustrated in the lower diagram above. Note that there is no space required between cabinets.

The 60-300 kVA cabinets are force-cooled by rear-mounted extraction fans which require a minimum of 200mm space at the rear of the cabinet to allow adequate exhaust air flow.

The 400-500 kVA cabinets are force-cooled by roof-mounted extraction fans and do not require any space at the rear of the cabinet but a minimum free space of 400mm is required above the cabinets to allow adequate exhaust air flow.

	60-100 kVA	120-200 kVA	250-300kVA	400-500kVA
Dimensions (WxHxD)mm	550x1820x750 970x1820x750 (Batt cab A) 1180x1820x750 (Batt cab B)	850x1820x750	1100x1920x750	1650 x 1994 x 850
Accessibility	Totally front accessibility for service and maintenance			
Positioning (for ventilation)	Min. 200 mm rear space			Min. 400mm space above cabinet
Input and Output Power Cabling	From the bottom at the front			

3.6 Planning the installation (cabling considerations)

3.6.1 General requirements

The information in this section should help with the preparation and planning of the UPS power cabling.

It is the customer's responsibility to provide all external fuses, isolators and cables that are used to connect the UPS input and output power supplies. The UPS input and bypass terminals should be connected to the utility mains supply through a suitable LV-Distribution board containing a circuit breaker or fused isolator to provide both overload protection and a means of isolating the UPS from the mains supply when required. Similarly, the UPS output supply terminals should be connected to the load equipment via a suitably fused load distribution board.

Input neutral grounding

A permanently connected input neutral is required to enable the rectifier to operate correctly and allow the UPS to function properly when operating on battery. The input neutral must also be grounded to permit correct operation when the UPS is running on battery.



Key Point: As the input neutral must be unswitched and connected to the UPS at all times, a 4-pole input switch or isolator must not be used at the LV Distribution board on a TN-S system.

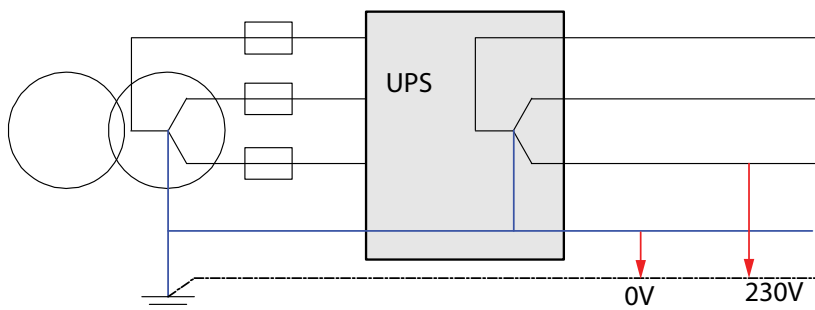

Figure 3.2 Input neutral grounding

3.6.2 Cable and fuse sizing

Single feed / Dual feed inputs

The UPS can be wired for a 'single feed' input (standard), whereby the UPS input mains terminals and bypass mains terminals are internally linked; or it can be wired for a 'dual feed' input, where the bypass links are removed and the UPS bypass mains terminals are connected to a dedicated bypass supply.

Both configurations are shown in Figure 3.3 (single feed) and Figure 3.4 (dual feed) together with details of the recommended fuse and cable ratings.



Key Point: The information in figures 3.3 and 3.4 is given for guidance only:

- **Fuse and Cable recommendations are to IEC 60950-1:2001.**
- All external fuses, isolators and power cables must be rated and installed in accordance with the prescribed IEC standards or local regulation – e.g. BS7671:2008.
- External DC Cables and battery fuses are bespoke to the installation.



IMPORTANT NOTE:

The 400kVA/500kVA module requires back access in order to change its input supply configuration between single-feed and dual-feed. If the module is to be located where rear access is restricted you must ensure you reconfigure its input supply configuration (if necessary) before it is moved to its final position.

See paragraph 3.10 for details

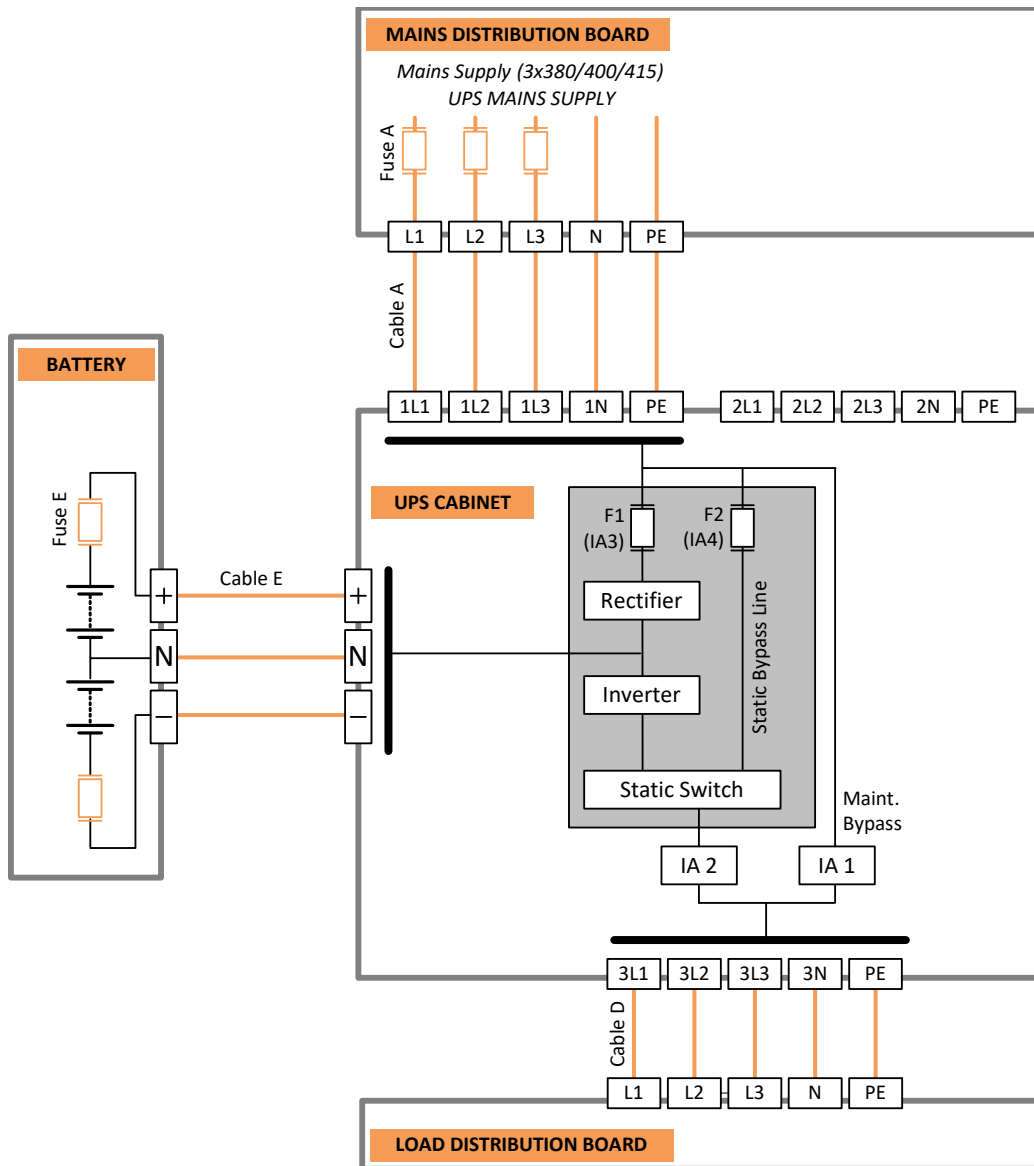

Power (kVA)	Fuse A (Agl/CB)	Cable A	Cable D
60	3x100	5x35	5x35
80	3x125	5x50	5x50
100	3x160	5x50	5x50
120	3x200	5x70	5x70
160	3x250	5x120 or 5x(2x50)	5x120 or 5x(2x50)
200	3x315	5x185 or 5x(2x70)	5x185 or 5x(2x70)
250	3x400	5x240 or 5x(2x95)	5x240 or 5x(2x95)
300	3x500	5x(2X120)	5x(2X120)
400	3x630	5x (3x95) or 5x (2x185)	5x (3x95) or 5x (2x185)
500	3x800	5x (3x150)	5x (3x150)

Note: Cable E and Fuse E are bespoke to the installation

Figure 3.3 Single feed input fuse and cable ratings

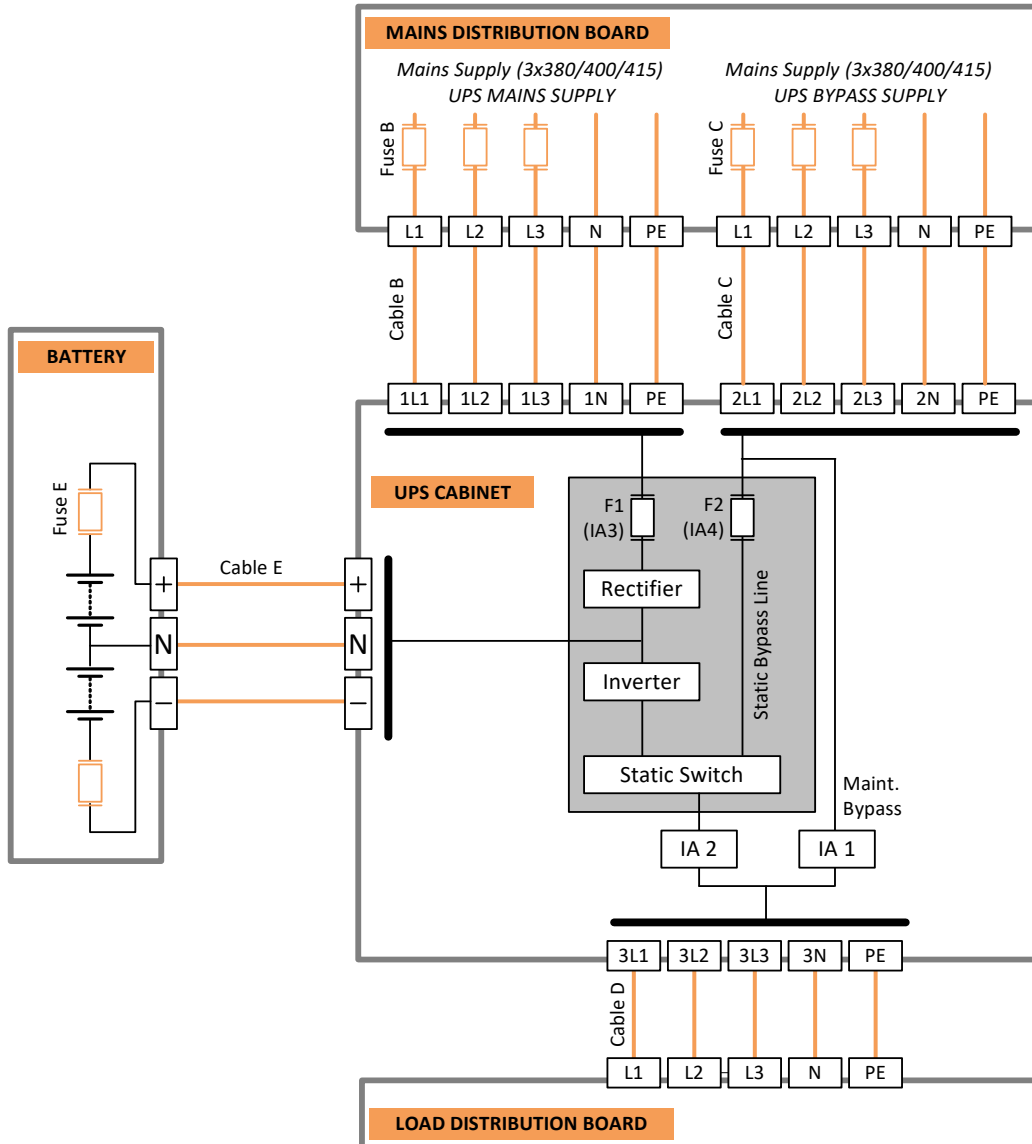

Power (kVA)	Fuse B (Agl/CB)	Cable B	Fuse C (Agl/CB)	Cable C	Cable D
60	3x100	5x35	3x100	5x35	5x35
80	3x125	5x50	3x125	5x50	5x50
100	3x160	5x50	3x160	5x50	5x50
120	3x200	5x70	3x200	5x70	5x70
160	3x250	5x120 or 5x(2x50)	3x250	5x120 or 5x(2x50)	5x120
200	3x315	5x185 or 5x(2x70)	3x315	5x185 or 5x(2x70)	5x185
250	3x400	5x240 or 5x(2x95)	3x400	5x240 or 5x(2x95)	5x240 or 5x(2x95)
300	3x500	5x(2x120)	3x500	5x(2x120)	5x(2x120)
400	3x630	5x(3x95) or 5x(2x185)	3x630	5x (3x95) or 5x(2x185)	5x(3x95) or 5x(2x185)
500	3x800	5x (3x150)	3x800	5x50	5x(3x150)

Note: Cable E and Fuse E are bespoke to the installation

Figure 3.4 Dual feed input fuse and cable ratings

3.6.3 Power cable terminations

The table below gives details of the cable termination sizes applicable to the various models across the PowerWAVE 6000 range. Figure 3.5 illustrates the terminal block/busbar layouts.

	Mains Supply (3+N+PE)	Bypass Supply (3+N)	Output Load (3+N+PE)	Battery (+ / N / - / PE)	Max admissible cable section (mm ²)	Tightening Torque (Nm)
60kVA	4 x 35 mm ² + PE M8	4 x 35 mm ²	4 x 35 mm ² + PE M8	4 x M8	35	3.5
80kVA	4 x 50 mm ² + PE M8	4 x 50 mm ²	4 x 50 mm ² + PE M8	4 x M8	50	5
100kVA	4 x 70 mm ² + PE M8	4 x 70 mm ²	4 x 70 mm ² + PE M8	4 x M8	95	8
120kVA	5 x M10	4 x M10	5 x M10	4 x M10	185	Max. 50
160kVA	5 x M10	4 x M10	5 x M10	4 x M10	185	Max. 50
200kVA	5 x M10	4 x M10	5 x M10	4 x M10	240	Max. 50
250kVA	5 x M10	4 x M10	5 x M10	4 x M10	240	Max. 50
300kVA	5 x M10	4 x M10	5 x M10	4 x M10	240	Max. 50
400kVA	3x (5 x M12)	3x (4 x M12)	3x (5 x M12)	3x (4 x M12)	240	Max 84
500kVA	3x (5 x M12)	3x (4 x M12)	3x (5 x M12)	3x (4 x M12)	240	Max 84

All the input and output power cables are routed through the bottom of the UPS cabinet below the power connectors/ busbars.

See the following assembly diagrams for details:

Figure 3.7 - 60kVA-100 kVA Module details

Figure 3.8 - 120kVA-200 kVA Module details

Figure 3.9 - 250kVA-300 kVA Module details

Figure 3.17 - 400kVA-500kVA Module details

3: Installation

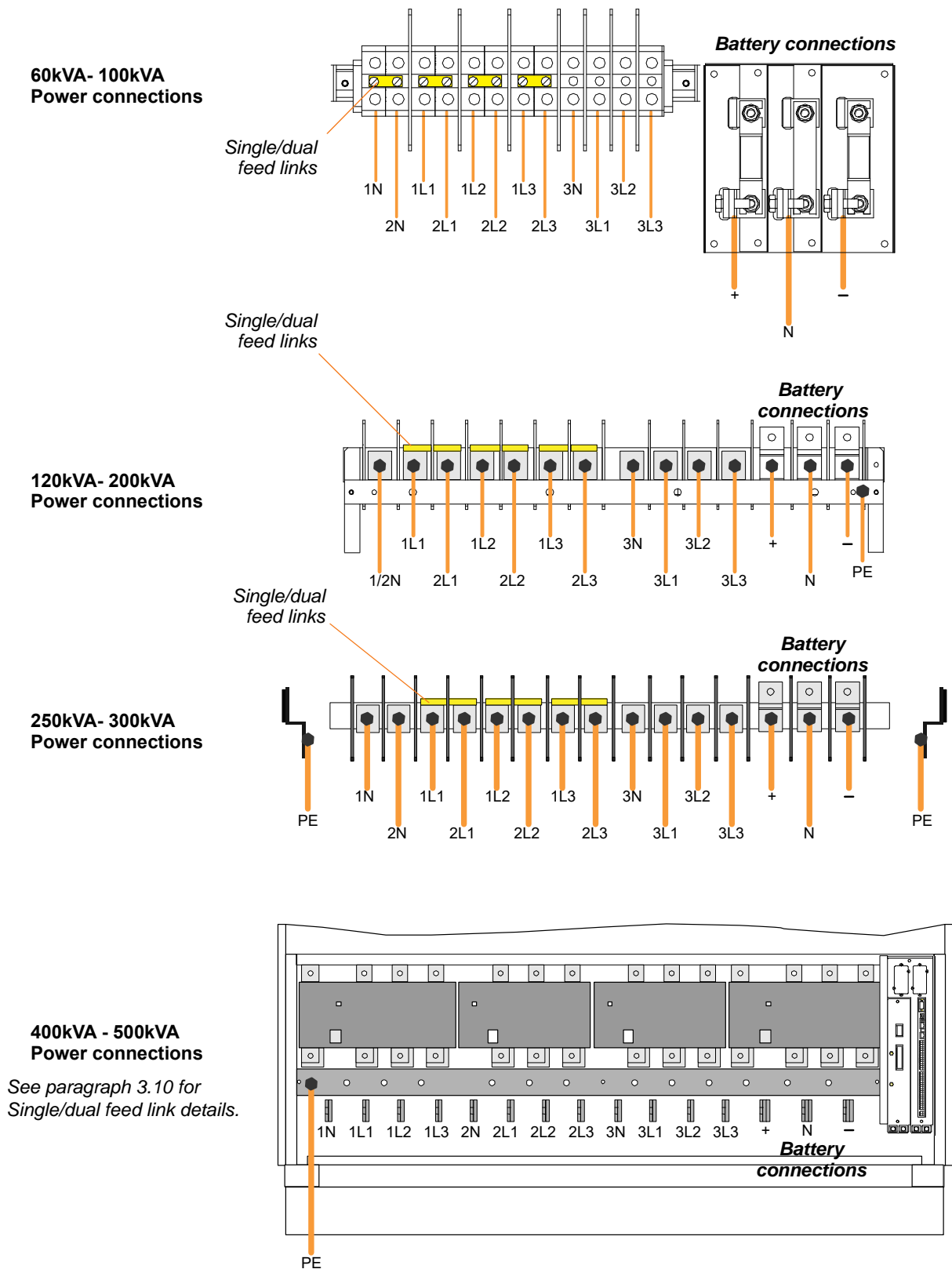

Figure 3.5 Input, output and battery power terminals

3.6.4 Power cabling in a parallel system

In order to achieve equal load sharing between the various UPS cabinets in a multi-cabinet installation, the input cables from the mains distribution board to each UPS cabinet should be of equal length. Similarly the UPS output cables to the load distribution board should be of equal length (See Figure 3.6).

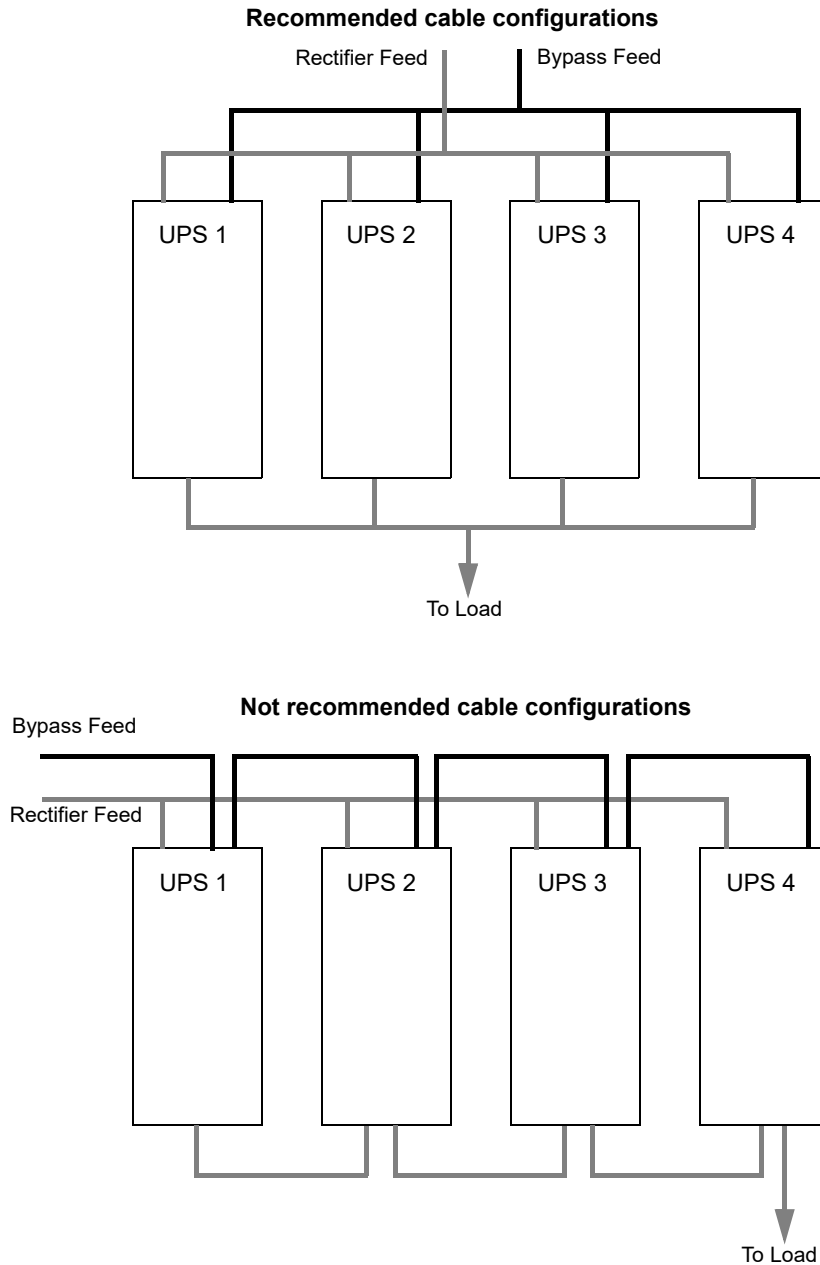

Figure 3.6 Cable lengths for multi cabinet configurations (dual feed input supply shown)

3.7 UPS Cabling procedure (60-300kVA models)



WARNING: Opening or removing the UPS-covers will create a risk of exposure to dangerous voltages if power is connected to the UPS.

Safety notes

Please ensure you read and understand the following safety notes before you begin the UPS electrical installation.

1. Do not commence this procedure until the UPS mechanical installation is completed.
2. All the cable installation procedures detailed below must be supervised by a qualified electrician.
3. Do not connect or operate the UPS if there is water or moisture present.
4. Before you work on the UPS power cables or terminals, you must ensure that the UPS input and load supplies are isolated and locked out at their respective distribution boards. Warning notices should be posted to prevent any inadvertent operation of the UPS supply isolators.
5. Before you connect the UPS input cables ensure that the customer-provided fuses and cables are suitably rated in accordance with the prescribed IEC standards or local regulations (for example BS7671:2008) – also see figures 3.3 and 3.4.
6. Once the electrical installation is completed the UPS must be commissioned by an engineer authorised by the manufacturer before it is brought into use.



WARNING: Do not apply electrical power to the UPS before it has been commissioned.

7. When installing the UPS cables ensure that the connection procedures are performed under the following conditions:
 - a) No mains voltage is present at the UPS mains/bypass distribution board terminals.
 - b) All loads are shut down and disconnected at the load distribution board.
 - c) The UPS is fully shut down and voltage-free.
 - d) The UPS Maintenance Bypass Isolator IA1 is open (OFF).
 - e) The UPS Parallel Isolator IA2 is open (OFF).

3.7.1 Connecting the input cables

1. Gain internal access to the UPS and remove the UPS terminal cover.
2. Connect the earth cable from the mains distribution board to the protective earth (PE) busbar located just below the UPS input terminals, as shown in Figures 3.7 to 3.9.

Single Input Feed

3. Refer to the schematic drawing and connection table in Figure 3.3.
4. Connect the UPS input supply cables to terminals 1L1, 1L2, 1L3 and 1N on the UPS terminal block. Ensure correct (clockwise) phase rotation.



CAUTION: The input Neutral cable must be unswitched and permanent.

5. Secure the cables to the fixing rail under the connection terminals.

Dual Input Feed

6. Refer to the schematic drawing and connection table in Figure 3.4.
7. The UPS is supplied for single feed input (as standard). For a dual feed configuration remove the links between 1L1-2L1; 1L2-2L2; 1L3-2L3 and 1N-2N, on the UPS terminal block.

Note: Details for changing the input configuration links on the 400/500kVA models are provided in paragraph 3.10.

8. Connect the UPS input supply cables to terminals 1L1, 1L2, 1L3 and 1N on the UPS terminal block. Ensure correct (clockwise) phase rotation.



CAUTION: The input Neutral cable must be unswitched and permanent.

9. Connect the earth cable from the bypass mains distribution board to the protective earth (PE) busbar located just below the UPS bypass terminals, as shown in Figures 3.7 to 3.17.
10. Connect the UPS bypass mains supply cables to terminals 2L1, 2L2, 2L3 and 2N on the UPS main terminal block. Ensure correct (clockwise) phase rotation.

Note: For 120-200kVA modules connect the bypass neutral to the same neutral terminal (N) as that used for the input supply.



CAUTION: The bypass Neutral cable must be unswitched and permanent

11. Secure the cables to the fixing rail under the connection terminals.

Note: The UPS commissioning engineer will re-configure the UPS electronics to operated with a dual feed input at the time of commissioning.

3.7.2 Connecting the UPS output cables

It is recommended that a separate load distribution board is provided for the load.

Before you begin connecting the UPS output cables to the load distribution board:

- Check that the potential full load does not exceed the UPS output power rating (OUTPUT POWER on the nameplate).
- Ensure the load circuit breakers on the load distribution board are correctly sized with respect to the load rating and associated cabling.
- Ensure that the maximum total load rating, and maximum load rating of each individual load socket, is indicated on the load distribution board.

The circuit breakers must comply with the prescribed IEC Standards (e.g. BS7671:2008).

1. Gain internal access to the UPS and remove the UPS terminal cover (if fitted).
2. Connect the protective earth cable from the load distribution board to the protective earth (PE) busbar in the UPS.
3. Connect the UPS output supply cables to terminals 3L1, 3L2, 3L3 and 3N on the UPS main terminal block. Ensure correct (clockwise) phase rotation.



CAUTION: The output Neutral cable must ALWAYS be connected.

4. Secure the cables to the fixing rail located under the UPS connection terminals.
5. Ensure the output cables are connected to the correct power terminals on the load distribution board.

3: Installation

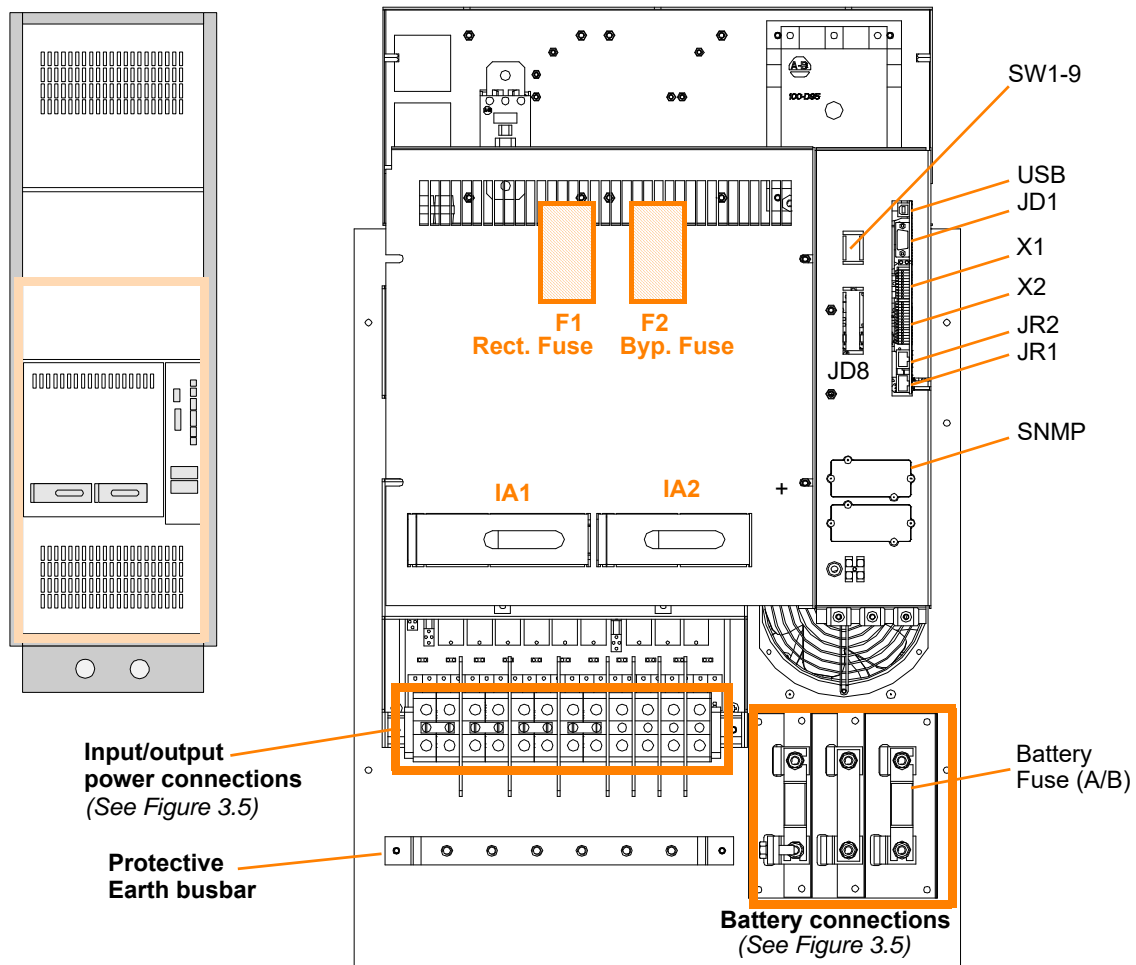

USB	PC Interface
JD1	RS232 Sub D9/female Interface (UPS system to computer)
X1	Customer Inputs
X2	Customer interface on Phoenix Terminals: X2= Potential free contacts
JR2	RS485 on RJ 45 port –Remote panel connection (see Section 3)
JR1	RS485 on RJ 45 port – Interface for Multidrop connection between several UPS cabinets
SW1-9	Multi-Cabinet Configuration Switch (see section 4)
JD8	Parallel BUS connector – ONLY For paralleling cabinets use optional adapter:
JD5	Parallel BUS - Input Connector
JD6	Parallel BUS - Output Connector
SNMP	Slot for optional SNMP card ONLY
IA1	Maintenance Bypass
IA2	Parallel Isolator
F2	Bypass Line Fuse
F1	Rectifier Fuse

Figure 3.7 60kVA-100 kVA Module details

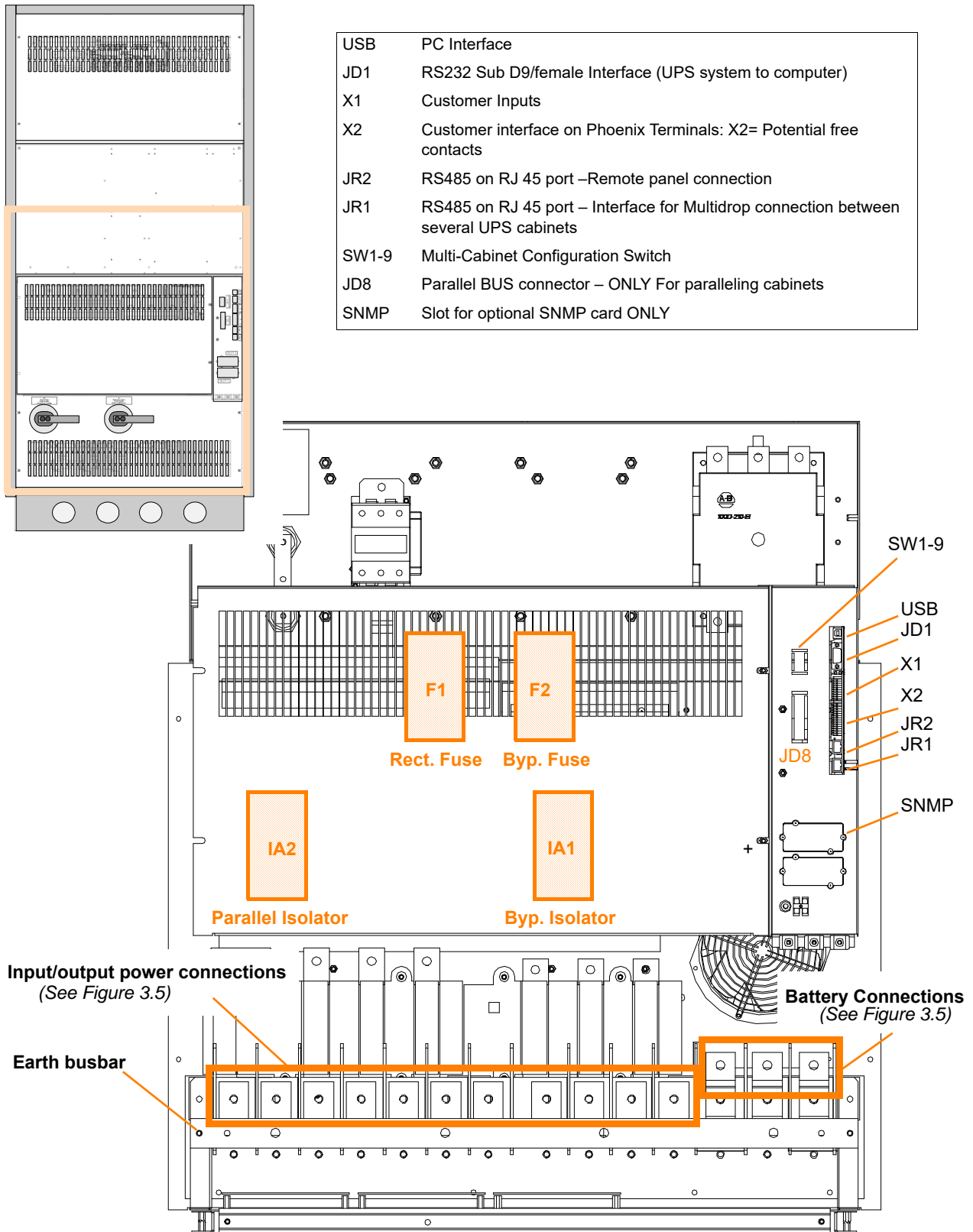

Figure 3.8 120kVA-200 kVA Module details

3: Installation

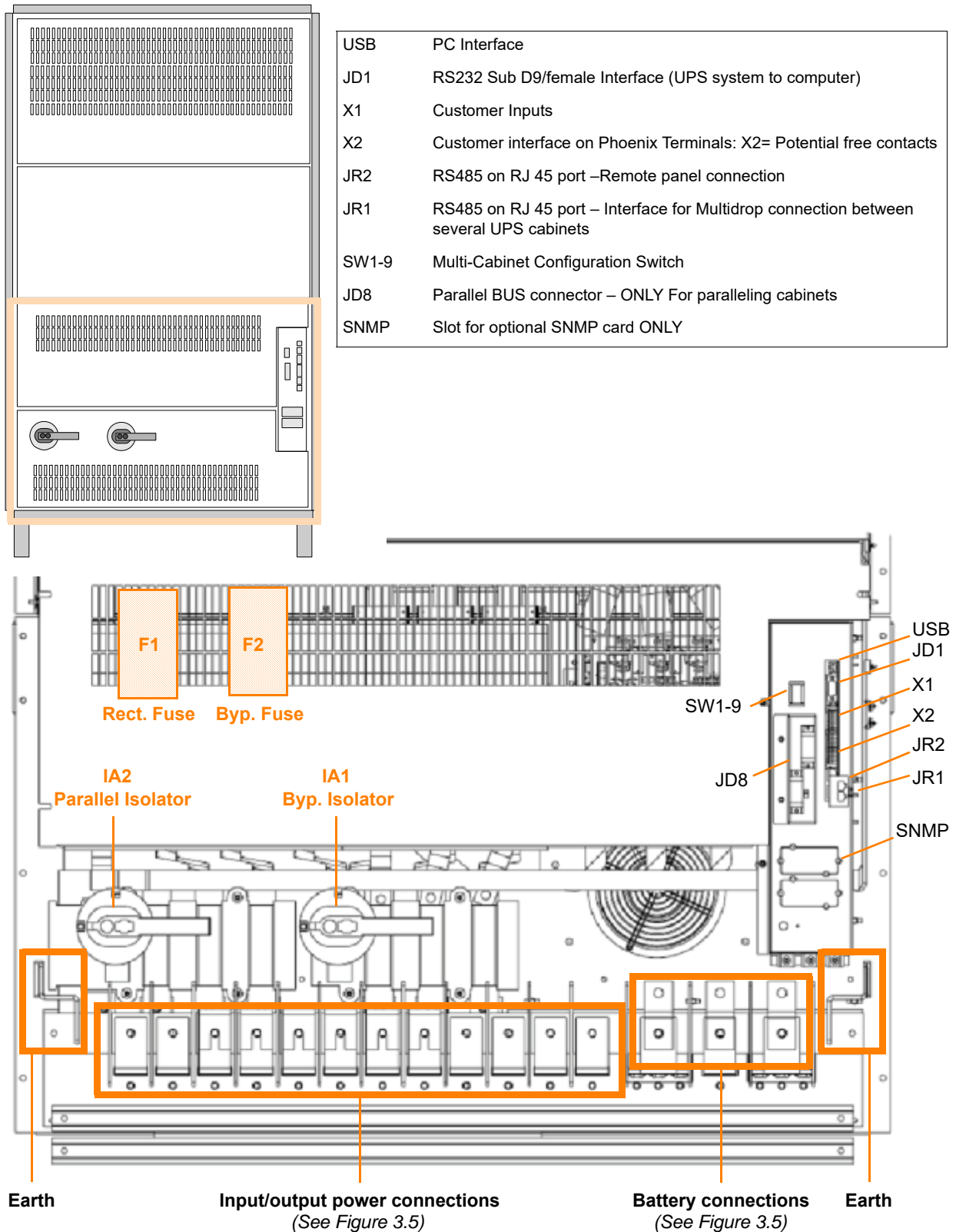

Figure 3.9 250kVA-300 kVA Module details

3.8 UPS Cabling procedure (400/500kVA models with bottom cable entry)



IMPORTANT: If you are installing the optional Top Cable Entry enclosure in conjunction with the 400kVA or 500kVA UPS cabinet refer to the UPS Cabling procedures in Paragraph 3.9.

Safety notes

Please ensure you read and understand the following safety notes before you begin the UPS electrical installation.

1. Do not commence this procedure until the UPS mechanical installation is completed.
2. All the cable installation procedures detailed below must be supervised by a qualified electrician.
3. Do not connect or operate the UPS if there is water or moisture present.
4. Before you work on the UPS power cables or terminals, you must ensure that the UPS input and load supplies are isolated and locked out at their respective distribution boards. Warning notices should be posted to prevent any inadvertent operation of the UPS supply isolators.
5. Before you connect the UPS input cables ensure that the customer-provided fuses and cables are suitably rated in accordance with the prescribed IEC standards or local regulations (for example BS7671:2008) – also see figures 3.3 and 3.4.
6. Once the electrical installation is completed the UPS must be commissioned by an engineer authorised by the manufacturer before it is brought into use.



WARNING: Do not apply electrical power to the UPS before it has been commissioned.

7. When installing the UPS cables ensure that the connection procedures are performed under the following conditions:
 - a) No mains voltage is present at the UPS mains/bypass distribution board terminals.
 - b) All loads are shut down and disconnected at the load distribution board.
 - c) The UPS is fully shut down and voltage-free.
 - d) The UPS Maintenance Bypass Isolator IA1 is open (OFF).
 - e) The UPS Parallel Isolator IA2 is open (OFF).

3.8.1 Introduction

In the 400/500kVA module the power cables are connected to busbars and secured using M12 bolts (see Figure 3.10). Each busbar has three holes to which the paralleled power cables can be attached. For reasons of clarity these are referred to as the 'rear', 'middle' and 'front' holes in the following procedure.

When using bottom cable entry, a cable support kit must be installed below the power terminals to provide a means of holding the cables securely in place.

The cable support kit, which contains all the necessary fittings and securing hardware, is shipped separate to the UPS cabinet and must be installed during the power cabling procedure. The kit comprises several cabinet-wide support bars that are fitted behind of each row of cables and must be installed progressively as the power cables are connected, as described below.

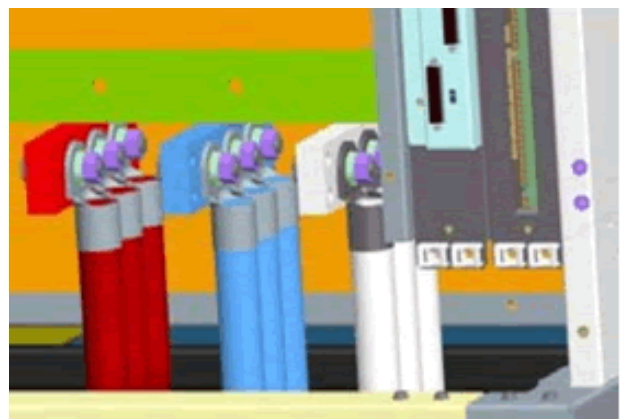

Figure 3.10 Power connections

3: Installation

3.8.2 Cabling procedure

1. Ensure the UPS module is configured appropriately for single/dual input supply operation – see paragraph 3.10.
2. After the UPS cabinet has been moved to its final position, remove and discard the two transport bars – shown in Figure 3.11.
3. Temporarily remove the front bottom bar.

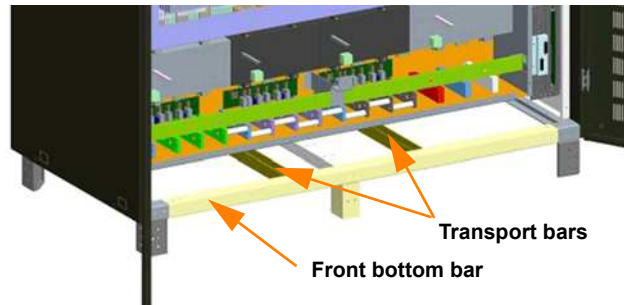

Figure 3.11

4. Instal the four profiles (A), (B), (C), (D) as illustrated in Figure 3.12. Each profile should be secured using two M5 screws tightened to a torque of 6.0 Nm.

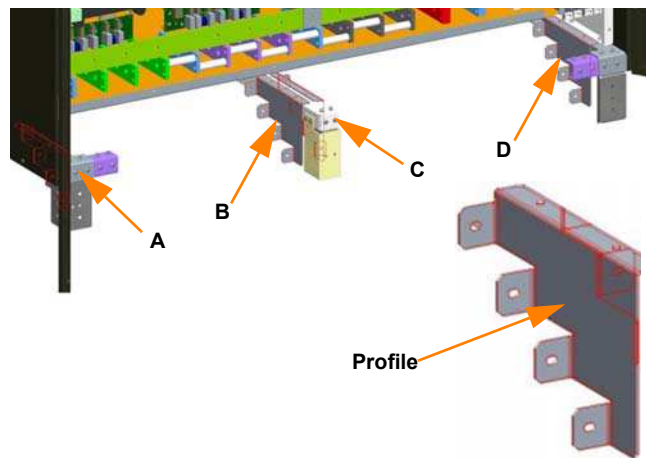

Figure 3.12

5. Fit two cable support bars (E), (F) between the rear-most lugs on profiles (A), (B), (C), (D) as shown in Figure 3.13. Secure each bar using two M5 nuts and bolts tightened to a torque of 6.0 Nm.
6. Connect the appropriate power cables to the rear holes in the busbar terminals (1N, 1L1, 1L2, 1L3), (2N, 2L1, 2L2, 2L3 in dual input system), (3N, 3L1, 3L2, 3L3), (Batt +, Batt N, Batt -).
7. Once the rear cables are connected secure them to the rear cable securing bars just fitted.

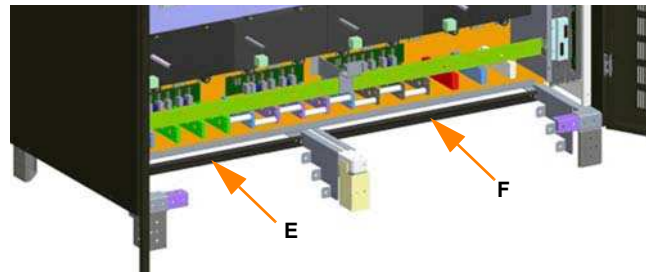

Figure 3.13

8. Fit two cable securing bars (G), (H) between the next set of lugs on profiles (A), (B), (C), (D) as shown in Figure 3.14. Secure each bar using two M5 nuts and bolts tightened to a torque of 6.0 Nm.
9. Connect the appropriate power cables to the middle holes in the busbar terminals (1N, 1L1, 1L2, 1L3), (2N, 2L1, 2L2, 2L3 in dual input system), (3N, 3L1, 3L2, 3L3), (Batt +, Batt N, Batt -).

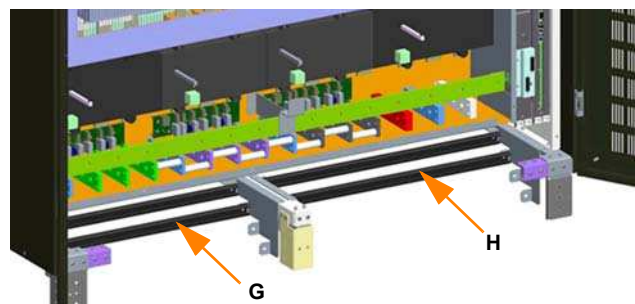

Figure 3.14

Note: For reasons of clarity the cables connected to the rear holes are not shown in Figure 3.14.

10. Once the middle cables are connected secure them to the middle cable securing bars just fitted.

11. Fit two cable securing bars (I), (J) between the next set of lugs on profiles (A), (B), (C), (D) as shown in Figure 3.15. Secure each bar using two M5 nuts and bolts tightened to a torque of 6.0 Nm.
12. Connect the appropriate power cables to the front holes in the busbar terminals (1N, 1L1, 1L2, 1L3), (2N, 2L1, 2L2, 2L3 in dual input system), (3N, 3L1, 3L2, 3L3), (Batt +, Batt N, Batt -).

Note: For reasons of clarity the cables connected to the rear and middle holes are not shown in Figure 3.15.

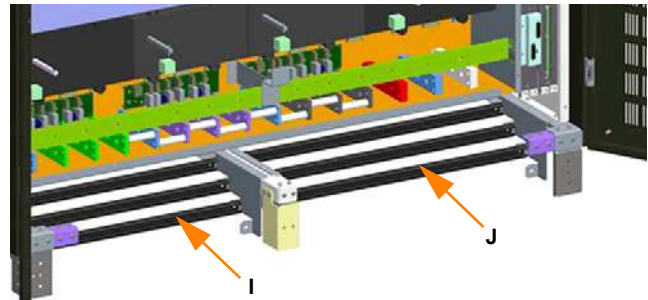

Figure 3.15

13. Once the front cables are connected secure them to the front cable securing bars just fitted.
14. Fit the final two cable securing bars (K), (L) between the front set of lugs on profiles (A), (B), (C), (D) as shown in Figure 3.16. Secure each bar using two M5 nuts and bolts tightened to a torque of 6.0 Nm.
15. Connect the Input, Bypass and output Earth cables to the earth busbar (M).

Note: For reasons of clarity the cables connected to the power busbars are not shown in Figure 3.14.

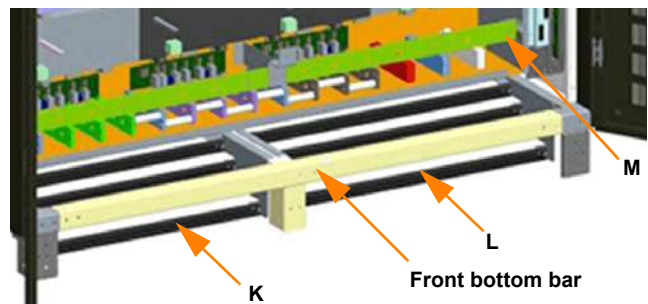

Figure 3.16

16. Once the earth cables are connected secure them to the cable securing bars just fitted.
17. Finally, refit the front bottom bar that was removed at the beginning of this procedure.
18. This completes the 400/500kVA module bottom entry power cabling.

3: Installation

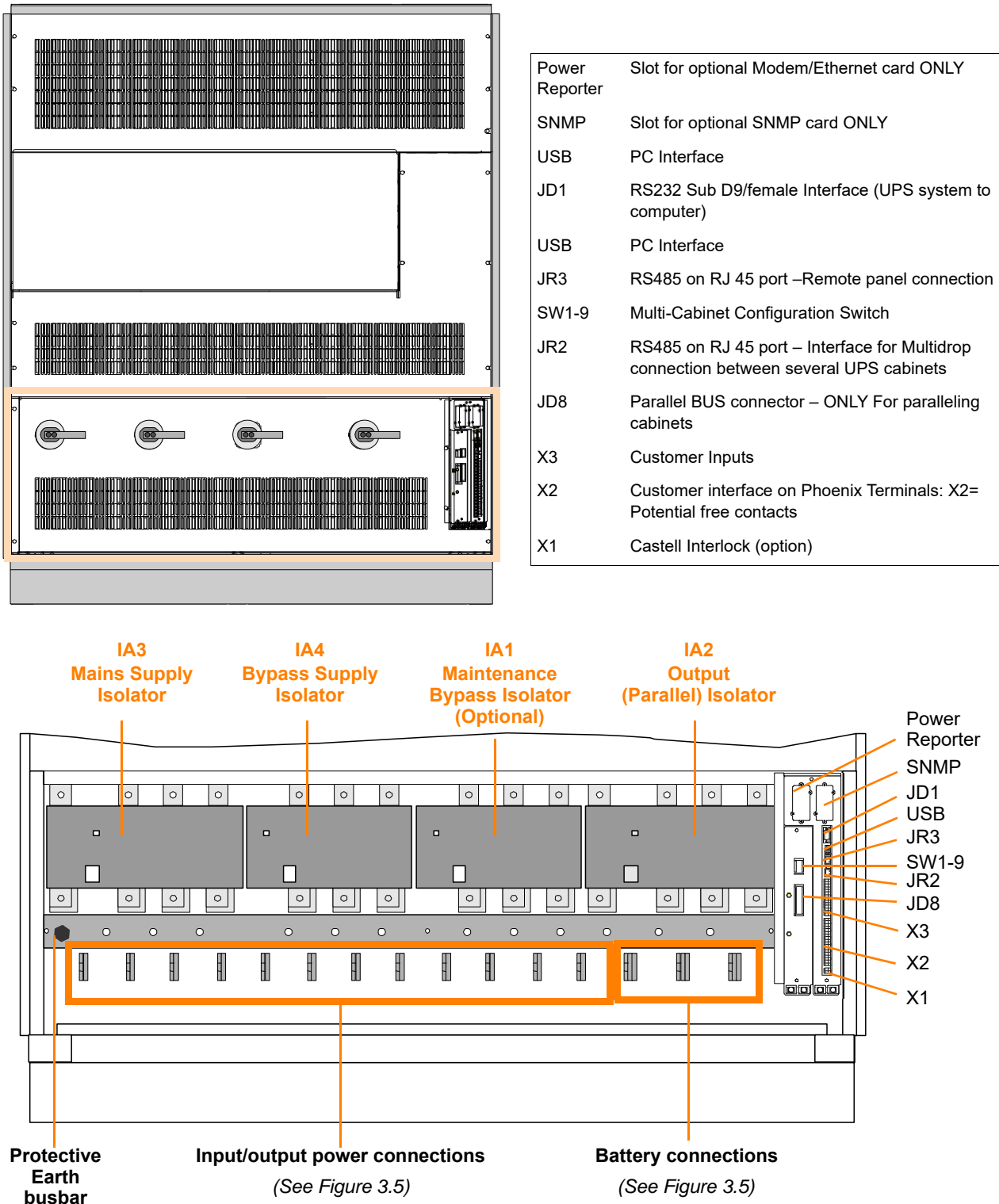

Figure 3.17 400kVA-500kVA Module details

3.9 UPS Cabling procedure (400/500kVA models with Top Cable Entry option)

3.9.1 Introduction

A Top Cable Entry (TCE) enclosure is available as an optional equipment item that can be used in conjunction with the 400kVA and 500kVA UPS models to facilitate top cable entry of the UPS input, output and battery power cables.

The TCE option equipment comprises:

- A purpose designed TCE enclosure containing all the necessary power connecting busbars.
- A hardware accessory pack that is used to attach the TCE enclosure to the UPS cabinet.
- A set of ready-made cables for connecting the TCE enclosure to the UPS power terminals.

The TCE enclosure, which is attached to the left hand side of the UPS cabinet, weighs **115 kg** and has dimensions of **500 x 1994 x 850 mm** (WxHxD).

The enclosure is delivered on a specifically designed pallet that can be moved easily using a forklift or a pallet jack. The accessories pack is delivered inside the enclosure and the cable set is delivered in a separate package.



WARNING: When handling the TCE enclosure or its packaging observe the precautions mentioned in 3.2.1.

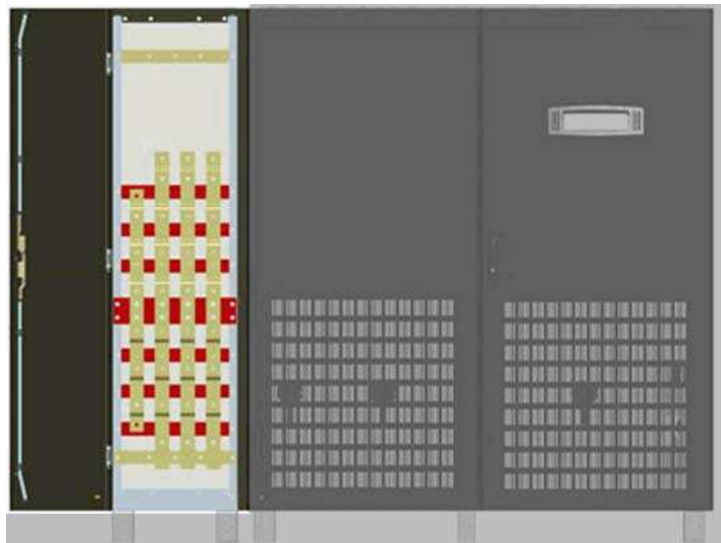

Figure 3.18 Optional top cable entry (TCE) enclosure in-situ

3.9.2 Installation notes

These notes outline the effects of installing the TCE enclosure on the installation procedures given earlier in this chapter.

Planning the installation

1. When installing the TCE enclosure, all the information and recommendations contained in paragraph 3.5 *Planning the installation (site considerations)* are still valid except for the dimensions shown in Figure 3.1 as the TCE enclosure will add a further *** mm to the width of the 400/500kVA units shown.
2. All external cable and fuse sizing data provided in 3.6.2 *Cable and fuse sizing* remain valid

UPS cabling procedure

1. The UPS cabling procedure contained in Paragraph 3.7 is superseded by the procedure in Paragraph 3.9.4.

UPS Input power configuration

1. On leaving the manufacturers, the UPS cabinet is configured for a single feed input supply. For a dual feed input you must reconfigure the UPS cabinet input connections following the procedure provided in paragraph 3.10.



Key Point: If required, we recommend that the input power configuration links are reconfigured before the TCE enclosure is installed. Note that there are no configuration changes required within the TCE enclosure regarding single/dual input supply operation.

3.9.3 TCE Enclosure mechanical installation

The TCE enclosure is attached to the left-hand side of the UPS cabinet using the hardware accessories pack that is shipped inside the enclosure. Before you install the enclosure you must ensure the that the UPS cabinet is correctly positioned at its intended final location.

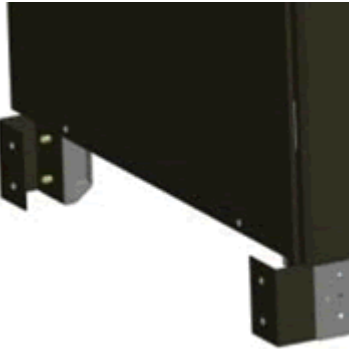

Figure 3.19 U- brackets

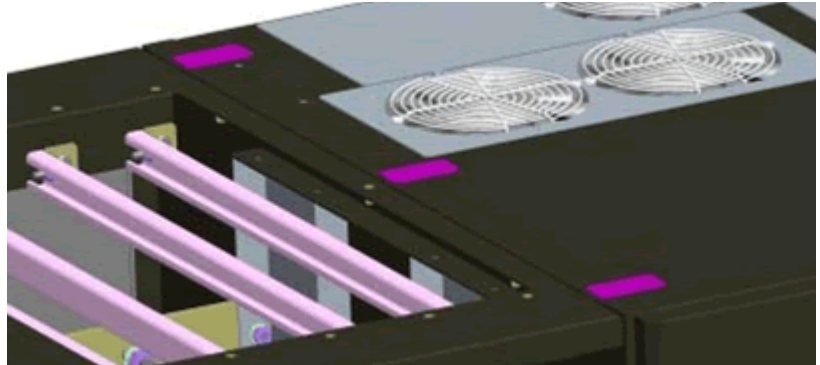

Figure 3.20 Cabinet tie bars

1. Unpack the TCE enclosure and remove any internal packing materials, taking care not to discard the hardware accessory pack. The accessories pack contains all the hardware and screws required to install the TCE enclosure as described below.
2. Attach two U shaped brackets to the base of the UPS cabinet using 2x M5 screws to secure each bracket, as shown in Figure 3.19 – affix the screws through the base of the UPS into the brackets.
3. Position the TCE enclosure adjacent to the UPS cabinet, ensuring that the front of the cabinets are properly aligned.
4. Attach the base of the TCE enclosure to the two U shaped brackets using 2x M5 screws to secure each bracket – affix the screws through the base of the enclosure into the brackets.
5. Using 6x M5 screws, secure the tops of the cabinets together by fitting three tie bars as shown in Figure 3.20.

3.9.4 TCE Enclosure cabling



WARNING: Opening or removing the UPS-covers will create a risk of exposure to dangerous voltages if power is connected to the UPS.

Safety notes

Please ensure you read and understand the following safety notes before you begin the UPS electrical installation.

1. Do not commence this procedure until the TCE/UPS mechanical installation is completed.
2. All the cable installation procedures detailed below must be supervised by a qualified electrician.
3. Do not connect or operate the UPS if there is water or moisture present.
4. When carrying out any work on the TCE/UPS power cables, or terminals, you must ensure that the TCE/UPS input and load supplies are isolated and locked out at their respective distribution boards. Warning notices should be posted to prevent any inadvertent operation of the UPS mains supply isolators.
5. Before you connect the input cables ensure that the customer-provided fuses and cables are suitably rated in accordance with the prescribed IEC standards or local regulations (for example BS7671:2008) – also see figures 3.3 and 3.4.
6. Once the electrical installation is completed the UPS must be commissioned by an engineer authorised by the manufacturer before it is brought into use.



WARNING: Do not apply electrical power to the UPS before it has been commissioned.

7. When installing the TCE/UPS cables ensure that these procedures are performed under the following conditions:
- No mains voltage is present at the TCE/UPS mains/bypass distribution board terminals.
 - All loads are shut down and disconnected at the load distribution board.
 - The UPS is fully shut down and voltage-free.
 - The UPS Maintenance Bypass Isolator IA1 is open (OFF).
 - The UPS Parallel Isolator IA2 is open (OFF).

Cable connection identification

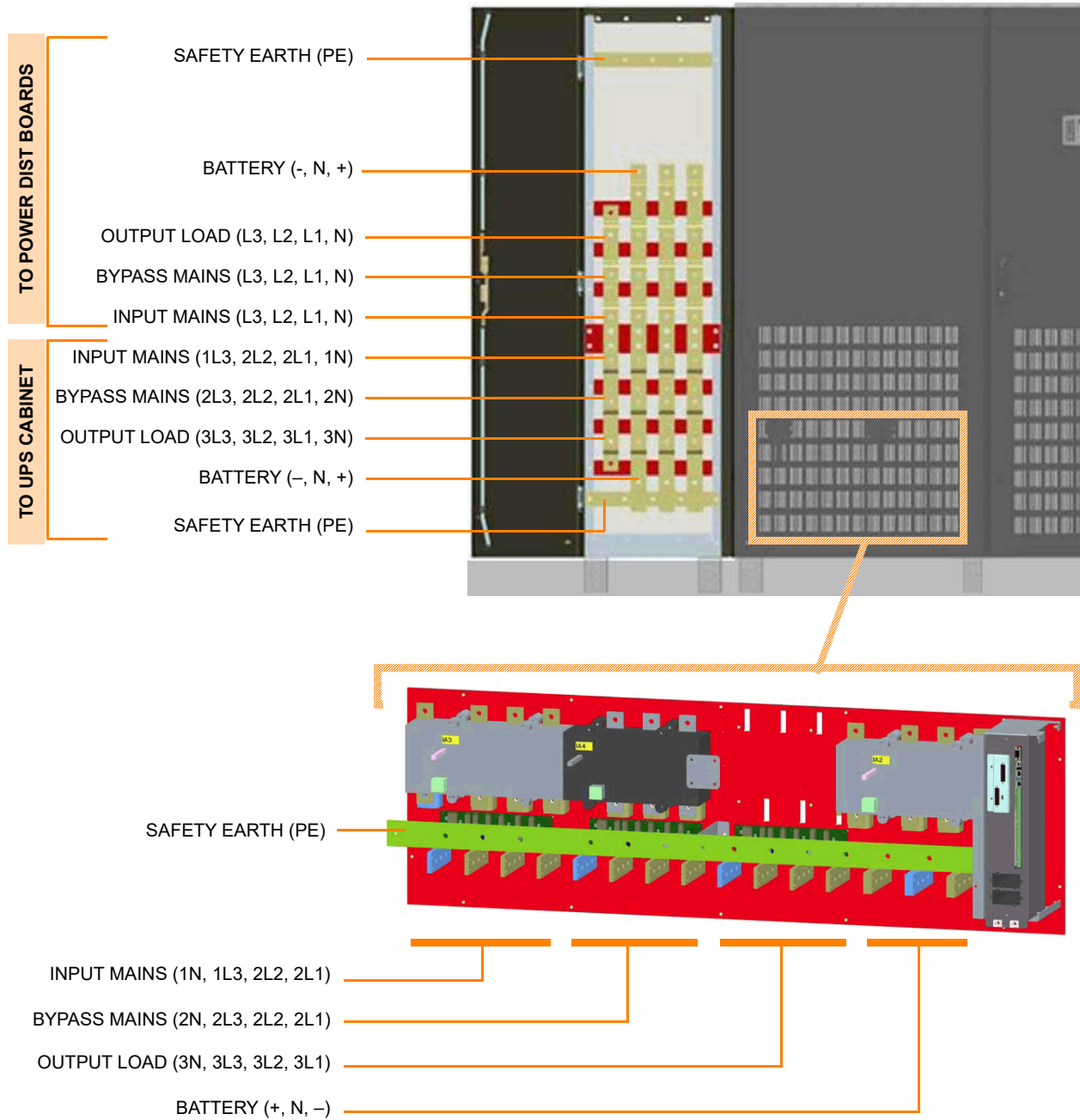

Figure 3.21 Power cables connection identification

3: Installation

Figure 3.21 identifies the power connections in the TCE enclosure and UPS cabinet. All power cables are connected to busbars using M12 bolts tightened to 84 Nm. Figure 3.21 illustrates that the busbars at the top of the TCE enclosure are connected to the external power sources while those at the bottom of the enclosure are connected to the power busbars in the UPS cabinet. The cables that are used to interconnect the TCE enclosure and UPS cabinet are supplied as part of the TCE equipment.

When connecting the power cables it is recommended that the UPS interconnecting cables are completely installed before fitting the TCE external power cables. Also, when installing the interconnecting cables they should be fitted in the order of battery cables followed by output load cables, bypass cables (dual feed system), rectifier cables, and finally earth cables. This sequence is recommended to optimise the position of each group of cables in the resulting cable loom that is formed below the UPS cabinet.

Each of the busbars in the UPS cabinet has three holes to which the cables can be connected, and where a power connection is made using multiple (paralleled) cables it is recommended that they are connected individually to the busbar where possible (see Figure 3.22).

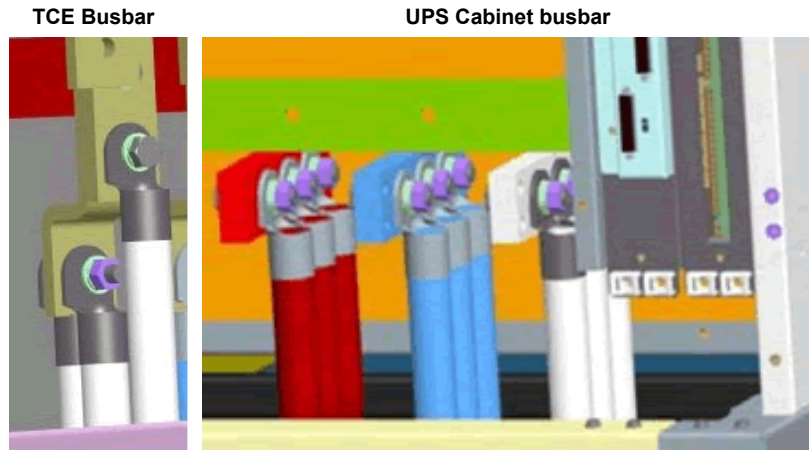
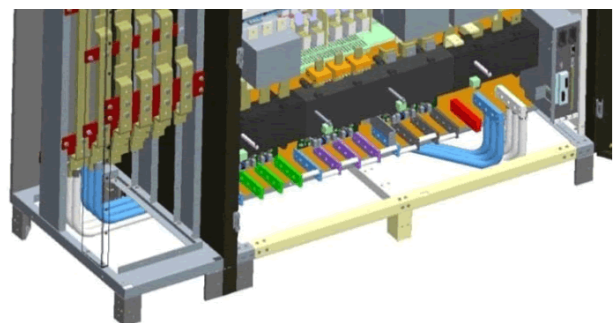
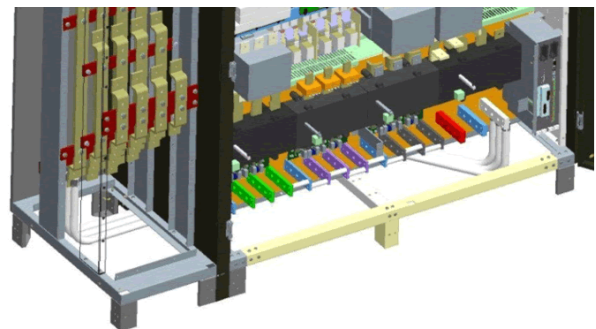

Figure 3.22 Busbar connections

Interconnection cabling procedure

1. Connect the battery negative cables to the TCE enclosure battery negative busbar (see also Figure 3.22).
2. Place the battery negative cables on the ground towards the back of the UPS cabinet.
3. Connect the battery negative cables to the UPS cabinet's battery negative busbar (see also Figure 3.22).
4. Connect the battery neutral cables to the TCE enclosure battery neutral busbar.
5. Place the battery neutral cables on top of the battery negative cables installed above, then connect them to the UPS cabinet's battery neutral busbar.



6. Connect the battery positive cables to the TCE enclosure battery positive busbar.
7. Place the battery positive cables on top of the battery neutral cables installed above, then connect them to the UPS cabinet's battery positive busbar.

The completed battery cabling should appear similar to that shown in the accompanying diagram.

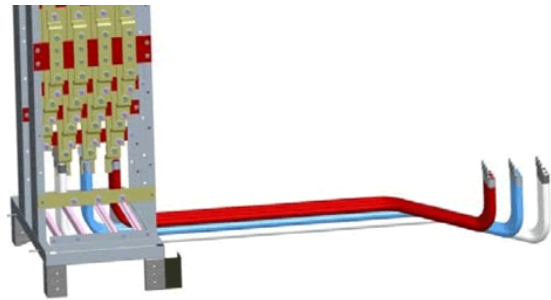

8. Repeat the above procedure for the UPS output cables. Begin by connecting the 3L3 cables between the TCE enclosure and the UPS cabinet. Placing the cables on the ground immediately in front of the battery cables.
9. Next connect the 3L2, 3L1 and 3N cables in turn placing each set of cables on the ones below.

The completed output cabling should appear similar to that shown in the accompanying diagram.

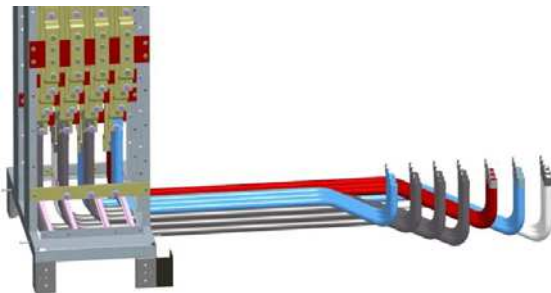

10. Repeat the above procedure for the bypass input cables (dual feed system only). Begin by connecting the 2L3 cables between the TCE enclosure and the UPS cabinet. Placing the cables on the ground immediately in front of the UPS output cables.

11. Next connect the 2L2, 2L1 and 2N cables in turn placing each set of cables on the ones below.

The completed output cabling should appear similar to that shown in the accompanying diagram.

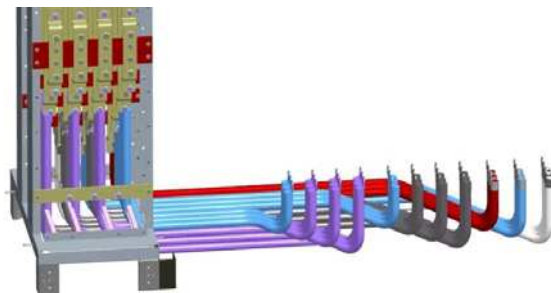

12. Repeat the above procedure for the input mains (rectifier) cables. Begin by connecting the 1L3 cables between the TCE enclosure and the UPS cabinet. Placing the cables on the ground immediately in front of the bypass input cables.

13. Next connect the 1L2, 1L1 and 1N cables in turn placing each set of cables on the ones below.

The completed output cabling should appear similar to that shown in the accompanying diagram.

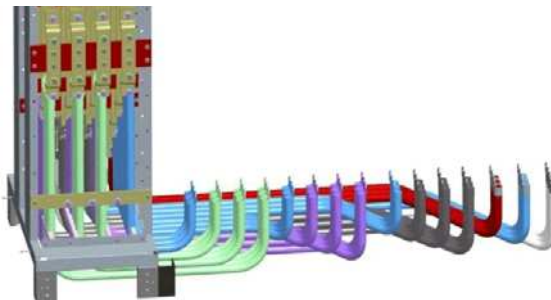

14. Finally, repeat the above procedure for the protective earth cables. Begin by connecting the PE3 cable between the TCE enclosure and the UPS cabinet. Placing the cables on the ground immediately in front of the input mains cables.

15. Next connect the PE2 and PE1 cables in turn placing each set of cables on the ones below.

The completed output cabling, will ALL the interconnecting cables should now appear similar to that shown in the accompanying diagram.

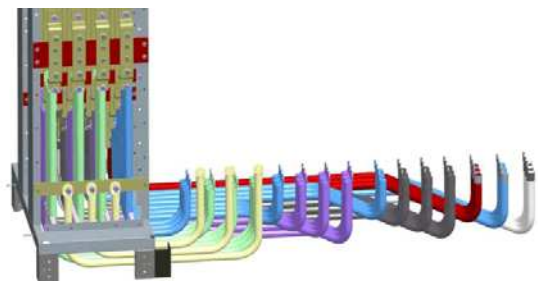

3.10 Single/Dual feed conversion for 400kVA/500kVA models



Key Point: The 400kVA/500kVA module requires back access in order to change its input supply configuration between single-feed and dual-feed. If the module is to be located where rear access is restricted you must ensure you reconfigure its input supply configuration (if necessary) before it is moved to its final position.

Unless otherwise specified, the UPS module is usually configured for a single feed input connections when it leaves the manufacturers. If required, you can convert the module to a dual feed input configuration using the following procedure:



CAUTION: UPS back panel weighs approximately 20kg. Take care when handling.

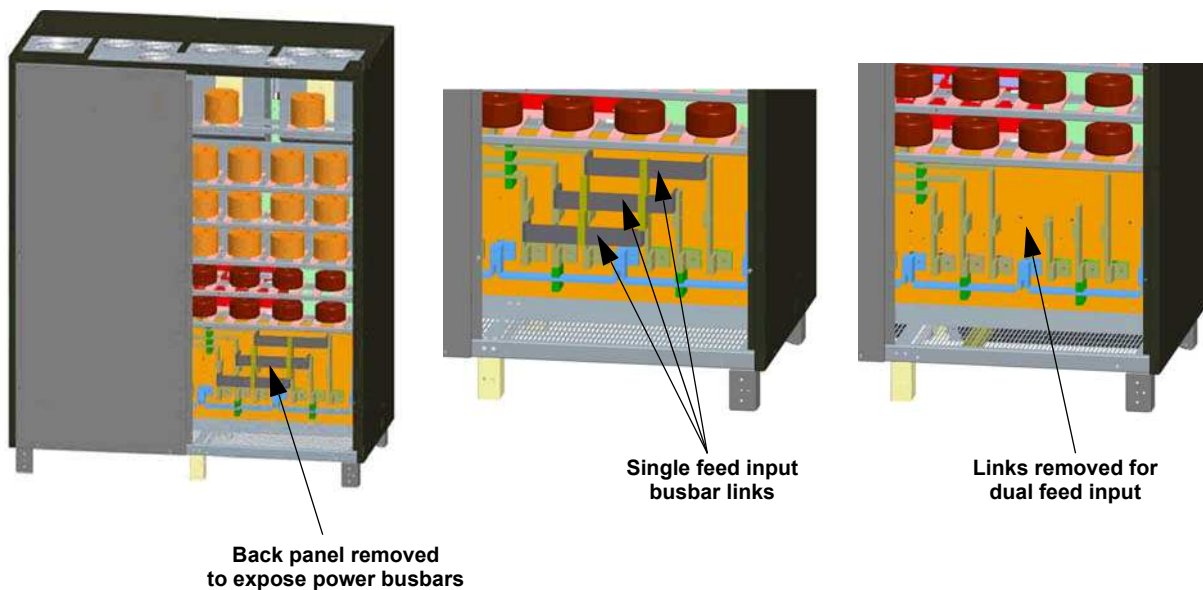

Figure 3.23 Input configuration for 400kVA/500kVA models

1. Gain access to the rear of the UPS module.
2. Remove the 10x M5 screws securing the UPS cabinet's right hand back panel then carefully remove it and stow it safely.
3. Remove the three busbar links identified in Figure 3.23. They are secured by 6x M10 nuts and bolts.
4. When the busbar links are removed, cover the holes exposed in the main busbars by refitting the 6x M10 nuts and tightening them to 5.0 Nm.
5. Refit the UPS right-hand back panel and secure it with the 10xM5 bolts removed earlier, tightening them to 6.0 Nm.

Note: Use the above procedure in reverse order if it is necessary to convert the UPS from a dual feed to single feed input.

3.11 Battery connections

3.11.1 'Sidecar' battery enclosure (60-100kVA)

Two 'sidecar' battery enclosures are available for attaching to the left-hand side of the UPS cabinet for modules rated up to (and including) 100kVA. Where used, these enclosures are permanently affixed to the UPS cabinet and form an integral part of the UPS. The optional enclosures are nominated as 'Enclosure A' and 'Enclosure B' (See Figure 3.24).

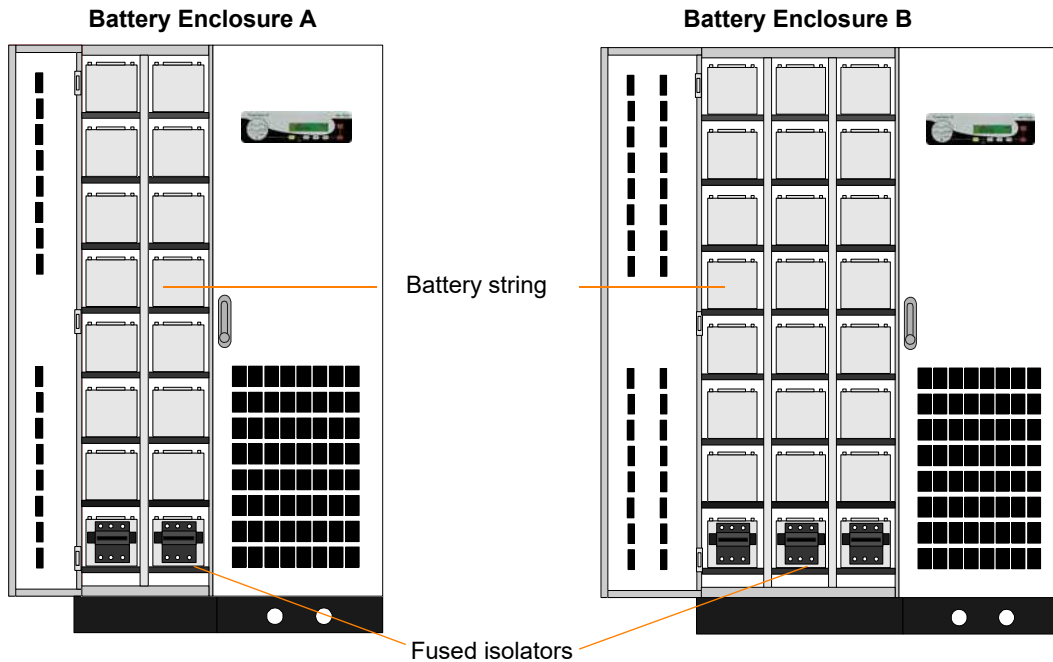

Figure 3.24 'Sidecar' battery enclosures (60kVA-100kVA UPS models only)

The sidecar enclosures are designed to be used with 24Ah or 38Ah battery blocks. The type A enclosure can house up to 80 blocks on 16 shelves whereas the type B enclosure can accept 120 blocks on 24 shelves – which equates to 5 blocks per shelf in each case.

Each column of shelves can be wired as an individual battery string with a fused isolator for each string fitted in front of the lower shelf. As the battery enclosure is shipped already attached to the UPS the internal wiring between the battery isolators and the UPS battery connection terminals is already made. The final assembly and connection of the battery blocks will be carried out by the commissioning engineer.



WARNING: Do not attempt to complete the battery wiring or close the battery isolators before the UPS system has been commissioned.

	BAT- ENC A	BAT- ENC B
Number of battery strings	1 - 2	1 - 3
Terminal size	3 x M8	3 x M8
Fuse type (very fast acting)	2 x 3 x 100A	3 x 3 x 100A
Combined dimensions of UPS and battery sidecar (WxHxD) mm	970x1820x750	1180x1820x750
Weight w/o trays and w/o batteries (kg)	20	30
Battery configuration with BAT-ENC A & B	Bespoke to installation	

Note: Only an even number of 12V-battery blocks can be used.

3.11.2 Remote battery enclosure

In a redundant system it is recommended that each UPS module is connected to a dedicated battery so that the system redundancy is expanded to also include the batteries. A range of bespoke battery enclosures can be supplied for the 60kVA-500kVA modules which are designed specifically to suit individual site requirements. In all cases, the battery enclosure will be fitted with suitably rated fused isolators which are connected on site to the battery terminals inside the UPS module.



WARNING: The final assembly and connection of the battery installation must be carried out by the commissioning engineer. Do not attempt to fit the batteries, complete the battery wiring or close the battery isolators before the system has been commissioned

3.11.3 Connecting the batteries



WARNING: This procedure must be carried out by (or under the supervision of) the approved UPS commissioning engineer.

1. To protect personnel during the battery installation ensure that the connections are performed under the following conditions:
 - a) No mains voltage is present at the UPS mains/bypass distribution board terminals.
 - b) All loads are shut down and disconnected at the load distribution board.
 - c) The UPS is fully shut down and voltage-free.
 - d) The UPS and battery connection terminals are voltage-free.
 - e) The UPS Maintenance Bypass Isolator IA1 is open (OFF).
 - f) The UPS Parallel Isolator IA2 is open (OFF).
 - g) The battery fuses and cables must be suitably rated.
Note that Battery fuse and cable ratings are bespoke to the installation.
2. Ensure that the fused isolators and/or circuit breakers in the external battery cabinet (or racks) are open.
3. Connect the protective earth cable (PE) between the UPS and external battery cabinet.
4. Connect the battery power cables between the module battery terminals (+, N, -) and the corresponding terminals on the external battery cabinet.

3.12 Multi-module control cabling and configuration

In order to facilitate various control functions such as load sharing, frequency synchronisation, and load transfer, all the UPS modules connected to a parallel system communicate with each other continuously by means of communication bus cables that are daisy-chained between each module, as shown below in figure 3.25. Once the cables are fitted, each module must be configured by means of a DIP switch according to its position in the parallel system.

3.12.1 Connecting the parallel communication bus cables

1. To protect personnel during the UPS installation ensure that the connections are performed under the following conditions:
 - a) No mains voltage is present at the UPS mains/bypass distribution board terminals.
 - b) All loads are shut down and disconnected at the load distribution board.
 - c) The UPS is fully shut down and voltage-free.
 - d) The UPS and battery connection terminals are voltage-free.
 - e) The UPS Maintenance Bypass Isolator IA1 is open (OFF).
 - f) The UPS Parallel Isolator IA2 is open (OFF).
2. Fit a parallel adaptor board over connector JD8 on the communications interface board in all UPS cabinets (JD8 is identified in Figure 3.26). The parallel adapter board contains a DIP switch (SW2-2) and two ribbon connectors, JD5 & JD6.
3. Set DIP switch SW2-2 on each parallel adaptor board according to the position of the UPS cabinet in the parallel configuration (See Figure 3.25).

4. Connect a bus-cable between JD6 of UPS cabinet 1 parallel adaptor and JD5 of UPS cabinet 2 parallel adaptor.
5. Connect a bus-cable between JD6 of UPS cabinet 2 parallel adaptor and JD5 of UPS cabinet 3 parallel adaptor.
6. Continue with the above steps until a bus-cable is connected to all modules, as shown below.

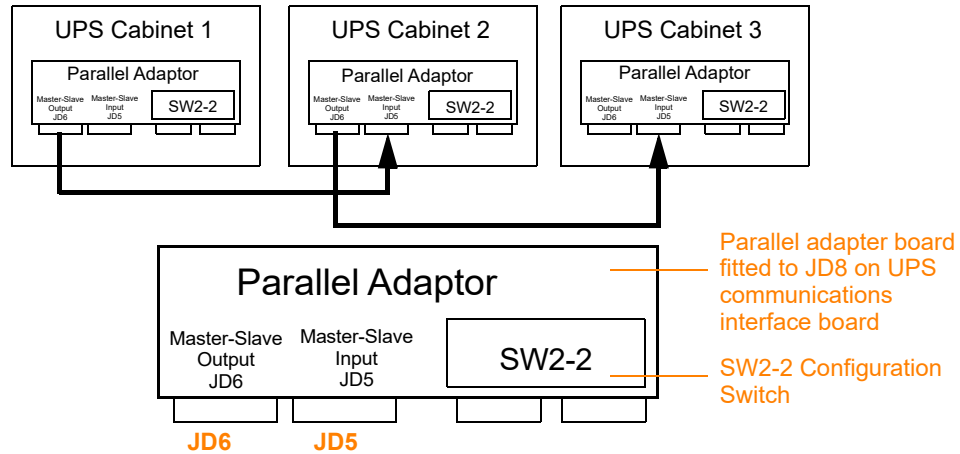

	Single Cabinet	First Cabinet	Middle Cabinet	Last Cabinet
SW 2-1	ON	OFF	OFF	ON
SW 2-2	ON	ON	OFF	OFF

Figure 3.25 Bus-lines connections (3 Modules shown)

3.12.2 Configuration DIP switch selection

DIP Switch SW1-9

DIP Switch SW1-9 on the UPS communications interface board (See Figure 3.26) must be set to indicate the position of the cabinet in the parallel chain. The three options are:

- First cabinet.
- Middle cabinet (there may be several 'middle' cabinets).
- Last cabinet.

1. In each cabinet, set Switch SW1-9 according to the table below:

SW1-9	Single Cabinet	First Cabinet	Middle Cabinet	Last Cabinet
1	ON	ON	OFF	ON
2	ON	OFF	OFF	ON
3	ON	ON	OFF	OFF
4	ON	ON	OFF	ON
5	ON	ON	OFF	ON
6	ON	ON	OFF	ON
7	ON	ON	OFF	ON
8	ON	ON	OFF	ON
9	ON	ON	OFF	ON

3.12.3 Module communications interface facilities

Each UPS is fitted with a communications interface board which enables various external monitoring and control applications to be connected to the system to satisfy particular site requirements.

Details of the interface facilities and available options are provided in Chapter 8.

Note: All used options should be installed and connected prior to commissioning the UPS so that they can be functionally checked as part of the commissioning procedure.

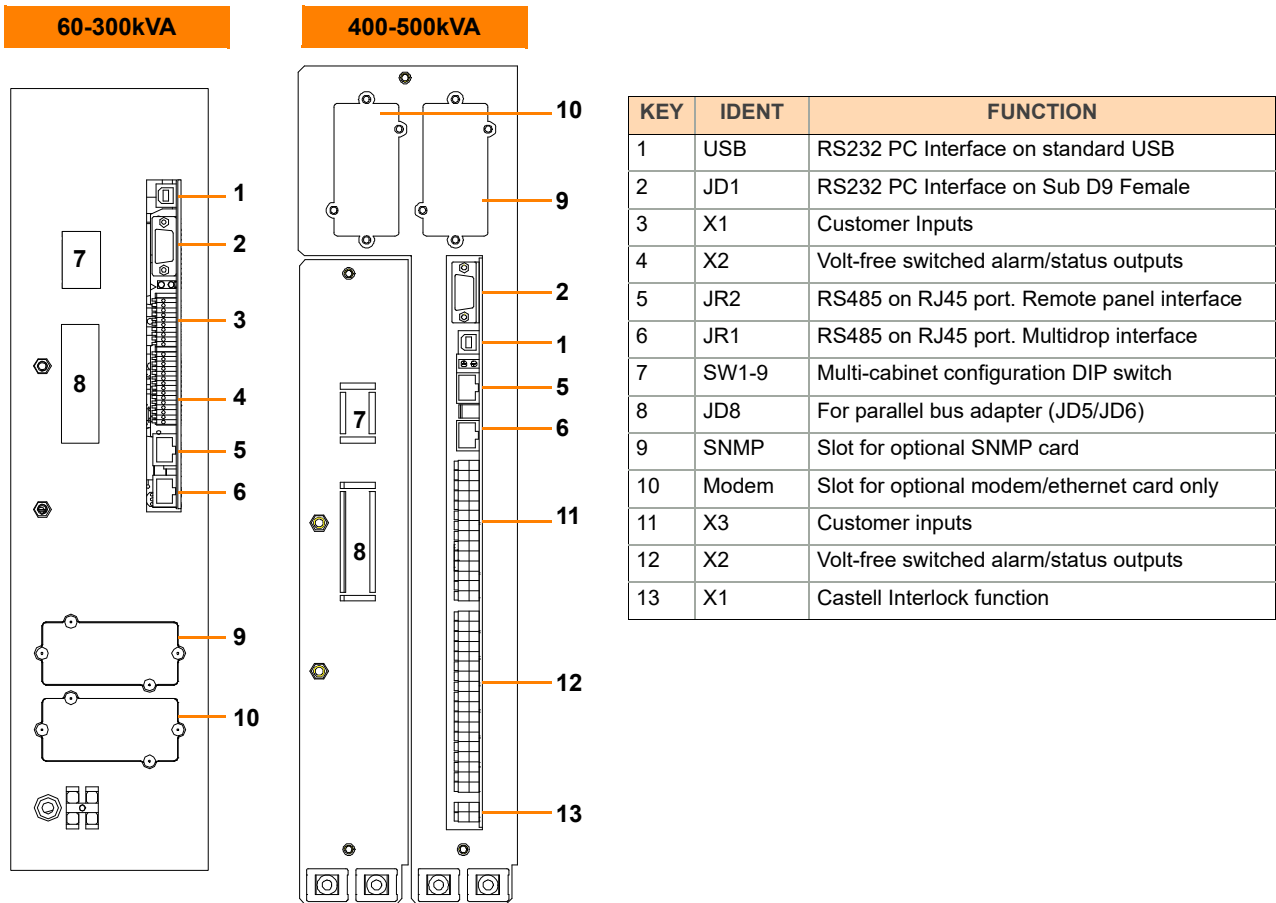

Figure 3.26 UPS Communications Interface Board connectors

4 Operating Instructions with LCD Control Panel

4.1 Introduction

The PowerWAVE 6000 UPS system must be commissioned by a fully trained field service engineer authorised by Uninterruptible Power Supplies Ltd before it is put into use.

The commissioning engineer will:

- Connect the UPS batteries.
- Check the UPS electrical installation and operating environment.
- Check the UPS cabinet paralleling configuration settings.
- Check the correct installation of any optional equipment.
- Perform a controlled UPS start-up and functionally test the system for correct operation and configuration.
- Carry out customer operator training and equipment handover.



WARNING: Uninterruptible Power Supplies Ltd. accepts no responsibility for the equipment or the safety of any personnel when operating this equipment before it has been properly commissioned.

The manufacturer's warranty is immediately invalidated if power is applied to any part of the UPS system before it has been fully commissioned and handed over to the customer.

4.1.1 Operating procedure summary

Under normal circumstances all the UPS modules in a multi-module system are running and operating in their 'on-line' (on inverter) mode.

If a UPS module fails or turned off in a redundant module system, the module will shut down but will not affect the remaining on-line modules, which will continue to supply the load with processed power. The failed module can then be repaired or tested off-line without affecting the remaining working modules.

If a UPS module fails or turned off in a capacity rated (or single module) system, the module immediately shuts down and the load transferred to the static bypass supply (*in all modules*) from where it is to the unprotected bypass mains supply.

The UPS cabinet contains a maintenance bypass switch which, when closed, connects the cabinet's output terminals directly to the bypass mains supply. When operating via the maintenance bypass switch, the UPS modules can be repaired or tested off-line as required.

Note: All the switches and control panel operations mentioned in this chapter are identified and described in chapter 2.

This chapter contains the following procedures:

Initial system power-up and functional testing – Paragraph 4.2

System shutdown to maintenance bypass – Paragraph 4.3

System start-up from maintenance bypass – Paragraph 4.4

Individual module stop/start procedure – Paragraph 4.5

4: Operating Instructions with LCD Control Panel

4.2 Initial system power-up and functional testing



WARNING: This procedure must be carried out by a trained engineer or service agent approved by UPS Ltd.

This procedure outlines the steps taken by the commissioning engineer when energising the UPS system for the first time. It can also be used to restart the system following a total shutdown.

Preliminary checks (for each UPS cabinet)

1. Check that the UPS input/bypass supply fuses or (breakers) are open (OFF) at the mains distribution board.
2. Check that the UPS power cabling has been performed correctly and the input phase rotation is correct.
3. Check that all the UPS module parallel switches (IA2) and maintenance bypass switches (IA1) are open (OFF).
4. Ensure that the UPS mains input fuses F1 and bypass input fuses F2 are open.
5. Ensure that the battery fuses (breakers) fitted in the UPS cabinet or external battery cabinets/racks are open (OFF).
6. Check that the parallel configuration DIP switches are set correctly in all cabinets (see paragraph 3.12.2).

Starting the UPS modules

1. Close the UPS input/bypass supply fuses or (breakers) at the mains distribution board.
2. On the UPS module close the mains input fuses F1/(IA3) and bypass input fuses F2/(IA4).

- a) The UPS mimic panel LINE 1 LED will be permanent green.
- b) The BATTERY LED will be flashing green.
- c) The LCD display will indicate LOAD OFF, SUPPLY FAILURE.

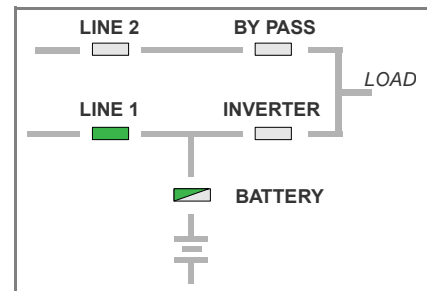

Key Point: During commissioning, the commissioning engineer can set-up the module's configuration data at this point – e.g. Set Time, Date, Module ID etc. This requires access to a password protected menu area and must be carried out only by an approved engineer.

3. Turn ON the UPS module by pressing both ON/OFF buttons simultaneously then releasing them.

- a) The UPS module will power up over approximately 60 seconds.
- b) Initially LINE 2 LED will be red, then change to green.
- c) The module control panel will display LOAD DISCONNECTED and PARALLEL SW OPEN.
- d) The module control panel mimic indications should be as shown here.

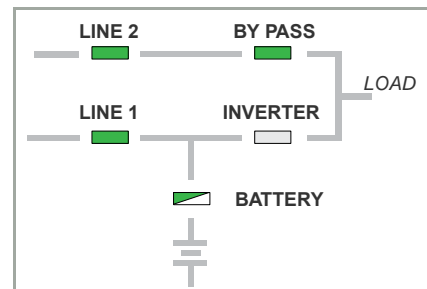

4. On the module control panel:

- a) Press the UP key once to access the menu system.
- b) Use the UP/DOWN keys to move the cursor so that it is adjacent to COMMANDS and then press the ENTER key.
- c) Use the UP/DOWN keys to move the cursor so that it is adjacent to LOAD TO INVERTER and then press the ENTER key.
- d) The UPS module output should transfer to inverter and the module control panel mimic indications should be as shown here.

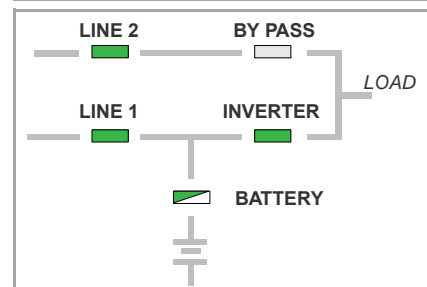

5. Scroll through the measurements menu and check that the module's input and output supply indications are correct.

6. Repeat steps 2 to 5 for all the other modules in the system and ensure that every module is in the state shown above before continuing with this procedure.
7. Check the battery voltage and polarity at the live side of the battery fuses (breaker) located in the UPS cabinet or external cabinet/rack with the fuses (breaker) still open.
8. If fitted, check the cabling between the UPS cabinet and battery cabinet (or rack) to determine that it is safe to connect the battery.
9. Close the battery fuses (breakers) fitted in the UPS cabinet or external battery cabinets/racks.
10. The BATTERY led on the module control panel mimic should change from flashing to permanent green.
11. Repeat the above steps for every UPS module so that the BATTERY led shows a permanent green on every module control panel.

Testing the parallel function

12. Ensure that the UPS output fuses (breakers) are open (OFF) at the load distribution board.
13. Turn OFF each UPS module in sequence by pressing both ON/OFF buttons simultaneously then releasing them.
 - a) The module control panel will display LOAD OFF and SUPPLY FAILURE.
 - b) The module control panel mimic indications should be as shown here.
14. Close the parallel switch (IA2) in each UPS module.
 - a) Each module control panel will display PARALLEL SW CLOSED.

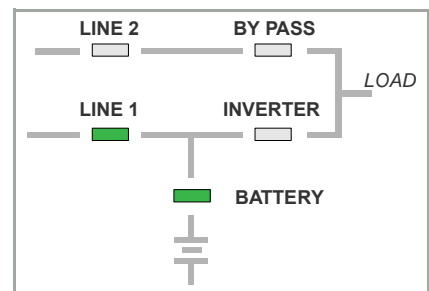

15. Turn ON each UPS module in sequence by pressing both ON/OFF buttons simultaneously then releasing them.
 - a) The UPS modules will all turn on and operate in their 'on-line' mode.
 - b) There is now power at the UPS output terminals, although the load is still isolated at the output distribution board.
 - c) The module control panel will display LOAD PROTECTED.
 - d) The module control panel mimic indications should be as shown here.

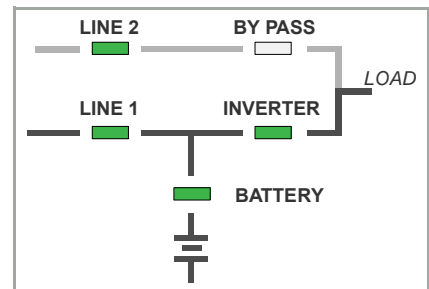

Transferring the output to maintenance bypass

16. On ANY UPS module control panel:
 - a) Press the UP key once to access the menu system.
 - b) Use the UP/DOWN keys to move the cursor so that it is adjacent to COMMANDS and then press the ENTER key.
 - c) Use the UP/DOWN keys to move the cursor so that it is adjacent to LOAD TO BYPASS then press the ENTER key.
 - d) The module control panel will display LOAD NOT PROTECTED.
 - e) The module control panel mimic indications should be as shown here.
17. Close the maintenance bypass switch (IA1) (in all cabinets).
 - a) The module control panel will display MANUAL BYP IS CLOSED.
 - b) The system control panel mimic should show the system running on maintenance bypass.
 - c) The module control panel mimic indications should be as shown here.

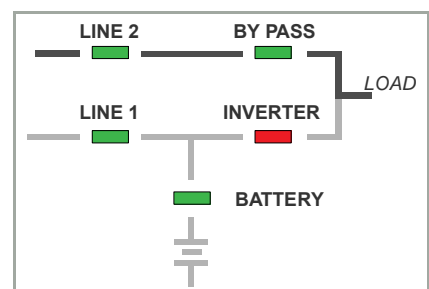
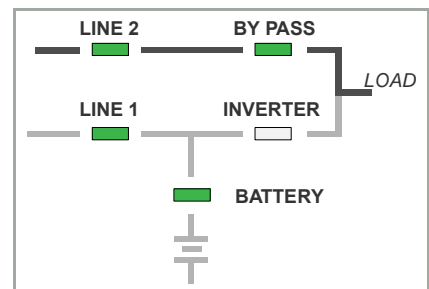

4: Operating Instructions with LCD Control Panel



WARNING: The next action will apply mains power to the load equipment.
 Check that the load is ready to receive power and that it is safe to do so before you continue.

18. Close the UPS output supply fuses (breakers) at the load distribution panel.
 - a) The load is now live and receiving power through the maintenance bypass circuit.

Transferring the load to the UPS

19. Ensure that the BYPASS led is green on ALL UPS module control panels.
20. Open the maintenance bypass switch (IA1) (in all UPS cabinets).
 - a) The module control panel will display MANUAL BYPASS OPEN followed by LOAD NOT PROTECTED.
 - b) The red INVERTER led will extinguish.
 - c) The module control panel mimic indications should be as shown here.

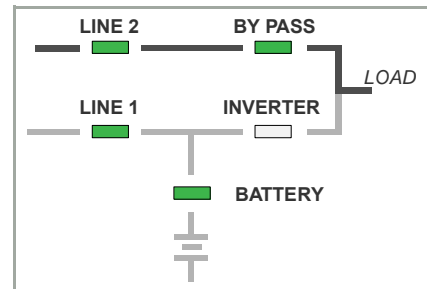

21. On ANY UPS module control panel:
 - a) Press the UP key once to access the menu system.
 - b) Use the UP/DOWN keys to move the cursor so that it is adjacent to COMMANDS and then press the ENTER key.
 - c) Use the UP/DOWN keys to move the cursor so that it is adjacent to LOAD TO INVERTER and then press the ENTER key.
 - d) The module control panel will display LOAD PROTECTED.
 - e) The module control panel mimic indications should be as shown here.

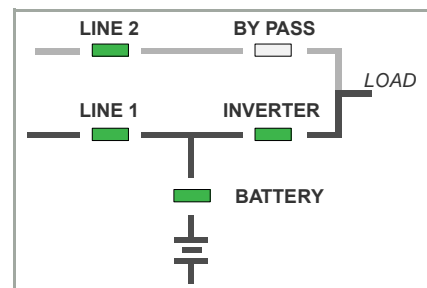

22. The UPS system is now operating in the 'on-line' mode and providing the load with protected power supplied by the modules' inverters.



Key Point: The UPS System (single or multi-module) is now in its normal operating mode.

4.3 System shutdown to maintenance bypass

It may be necessary to transfer the load to the maintenance bypass supply to perform certain service or maintenance operations – for example, when repairing a module in a single module or capacity parallel module system.



CAUTION: Warn the critical load user that the load will not be supplied with processed, backed-up power when the UPS is operating on maintenance bypass.

1. On the UPS control panel (on any module in a multi-module system) press the ENTER key once to access the menu system.
2. Using the UP/DOWN keys, move the cursor so that it is adjacent to COMMANDS and then press the ENTER key.
3. Using the UP/DOWN keys, move the cursor so that it is adjacent to LOAD TO BYPASS and then press the ENTER key.
 - a) The UPS system will transfer the load to static bypass (on all UPS modules in a multi-module system).
4. On all modules check and confirm that:
 - a) The INVERTER LED has extinguished.
 - b) The BYPASS LED is green.
 - c) The LCD displays LOAD NOT PROTECTED.
 - d) The module control panel mimic indications should be as shown here.

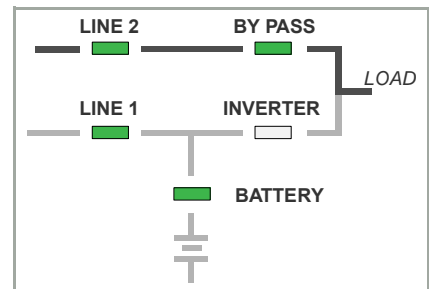

5. Close the maintenance bypass switch (IA1) (in ALL cabinets).
 - a) The module control panel will display MANUAL BYP IS CLOSED.
 - b) The module control panel mimic indications should be as shown here.

Note: The system is now operating in the 'maintenance bypass' mode with the UPS modules running but totally off-line. If you want to shut-down any (or all) the modules, continue with the procedure as follows.

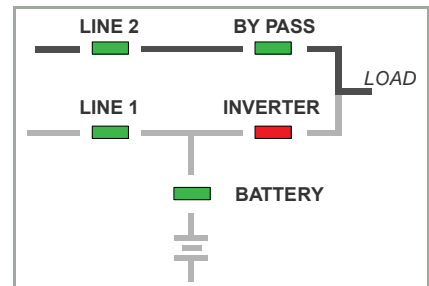

To power-down a UPS module

6. Turn OFF the UPS module by pressing both ON/OFF buttons simultaneously then releasing them.
 - a) The module control panel will display LOAD OFF and SUPPLY FAILURE.
 - b) The module control panel mimic indications should be as shown here.

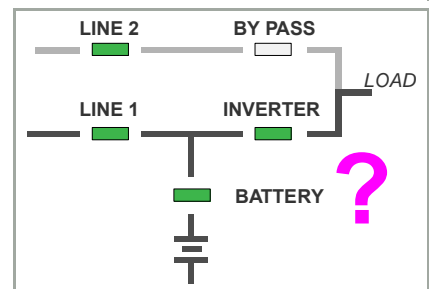

7. Open the module's parallel switch (IA2).
8. Open the battery fuses in the UPS cabinet or external cabinet/racks.
 - a) The BATTERY led on the module mimic should change to flashing green.
 - b) The module control panel mimic indications should be as shown here.
9. Open the mains input fuses F1 and bypass input fuses F2.
 - a) The module is now fully powered down.

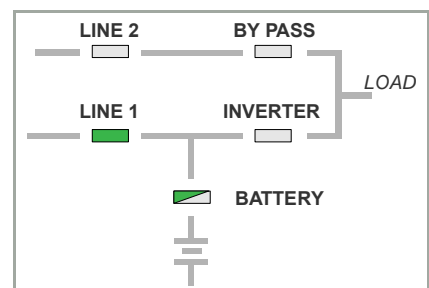

WARNING: The UPS module is still live at its input and output power terminals due to the activation of Maintenance Bypass circuit. Allow 10 minutes for the internal DC capacitors to discharge before touching any UPS internal components.

4: Operating Instructions with LCD Control Panel

4.4 System start-up from maintenance bypass

This procedure applies to both single module and multi-module systems and describes how to return the UPS system to normal (on-line) operation from working on the maintenance bypass.

Note: If all the UPS modules are already running, begin this procedure at step 5, otherwise begin at step 1 to turn on any non-working module(s).

1. Close the battery fuses in the UPS cabinet or external cabinet/racks.
2. Close the mains input fuses F1 and bypass input fuses F2.
 - a) The module control panel will display LOAD OFF, SUPPLY FAILURE.
 - b) The BATTERY led on the module control panel mimic should change from flashing to permanent green.
 - c) The module control panel mimic indications should be as shown here.

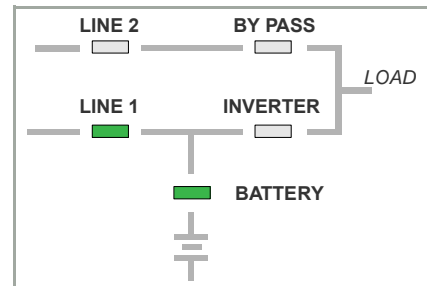

3. Close the parallel switch (IA2) for each module.
 - a) The module control panel will display PARALLEL SW CLOSED on every module.
4. Turn ON the UPS module(s) by simultaneously pressing both ON/OFF buttons then releasing them.
 - a) The UPS module(s) will start-up over about 60 seconds.
 - b) The module control panel will display MANUAL BYP IS CLOSED.
 - c) The module control panel mimic indications should be as shown here.

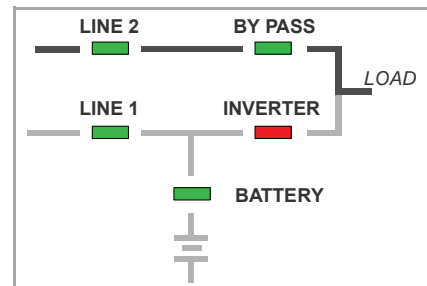

5. Ensure that the BYPASS LED is green on ALL UPS module control panels.

6. Open the maintenance bypass switch (IA1) (in all UPS cabinets).
 - a) The module control panel will display MANUAL BYPASS OPEN followed by LOAD NOT PROTECTED.
 - b) The red INVERTER LED will extinguish.
 - c) The module control panel mimic indications should be as shown here.

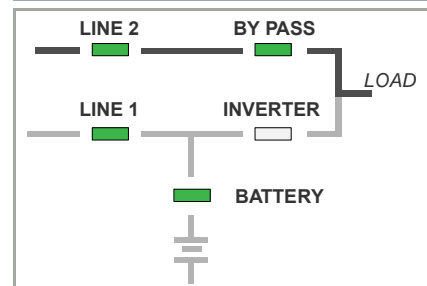

7. On ANY UPS module control panel:
 - a) Press the UP key once to access the menu system.
 - b) Use the UP/DOWN keys to move the cursor so that it is adjacent to COMMANDS and then press the ENTER key.
 - c) Use the UP/DOWN keys to move the cursor so that it is adjacent to LOAD TO INVERTER and then press the ENTER key.
 - d) The module control panel will display LOAD PROTECTED.
 - e) The module control panel mimic indications should be as shown here.

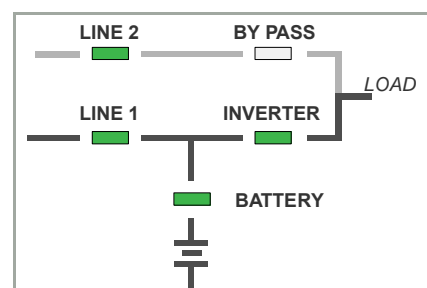

Note: This completes the procedure. The UPS is now operating in 'On-Line' mode and supply protected load power.

4.5 Individual module stop/start procedure

4.5.1 Single module system and capacity parallel module system

Module shutdown:

In a single module or capacity-rated parallel module system this action will transfer the load to the bypass supply.



CAUTION: Warn the critical load user that the load will not be supplied with processed, backed-up power when the UPS is operating on maintenance bypass.

1. On the UPS control panel press the ENTER key once to access the menu system.
2. Using the UP/DOWN keys, move the cursor so that it is adjacent to COMMANDS and then press the ENTER key.
3. Using the UP/DOWN keys, move the cursor so that it is adjacent to LOAD TO BYPASS and then press the ENTER key.
 - a) The UPS system will transfer the load to static bypass (on all UPS modules in a multi-module system).

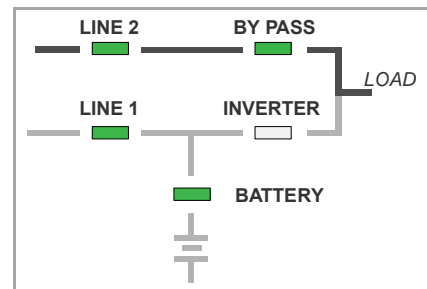

4. Turn OFF the UPS module by pressing both ON/OFF buttons simultaneously then releasing them.
 - a) The module control panel will display LOAD OFF and SUPPLY FAILURE.
 - b) The module control panel mimic indications should be as shown here.

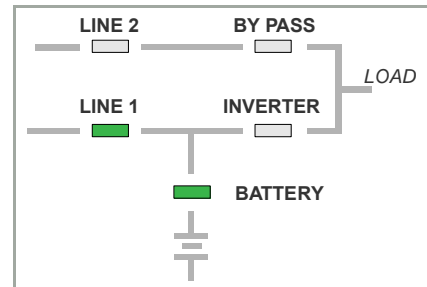

5. Open the module's parallel switch (IA2).
6. Open the battery fuses in the UPS cabinet or external cabinet/racks.
 - a) The BATTERY led on the module mimic should change to flashing green.
 - b) The module control panel mimic indications should be as shown here.
7. Open the mains input fuses F1 and bypass input fuses F2.
 - a) The module is now fully powered down.

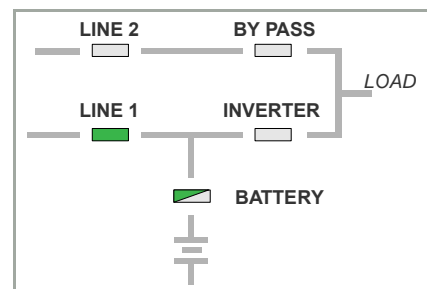

WARNING: The UPS module is still live at its input and output power terminals due to the activation of Maintenance Bypass circuit. Allow 10 minutes for the internal DC capacitors to discharge before touching any UPS internal components.

4: Operating Instructions with LCD Control Panel

Module start-up:

1. Close the battery fuses in the UPS cabinet or external cabinet/racks.
2. Close the mains input fuses F1 and bypass input fuses F2.
 - a) The module control panel will display LOAD OFF, SUPPLY FAILURE.
 - b) The BATTERY led on the module control panel mimic should change from flashing to permanent green.
 - c) The module control panel mimic indications should be as shown here.
3. Close the parallel switch (IA2).
 - a) The module control panel will display PARALLEL SW CLOSED on every module.
4. Turn ON the UPS module by simultaneously pressing both ON/OFF buttons then releasing them.
 - a) The UPS module will start-up over about 60 seconds.
 - b) The module control panel mimic indications should be as shown here.
5. On the UPS module control panel:
 - a) Press the UP key once to access the menu system.
 - b) Use the UP/DOWN keys to move the cursor so that it is adjacent to COMMANDS and then press the ENTER key.
 - c) Use the UP/DOWN keys to move the cursor so that it is adjacent to LOAD TO INVERTER and then press the ENTER key.
 - d) The module control panel will display LOAD PROTECTED.
 - e) The module control panel mimic indications should be as shown here.

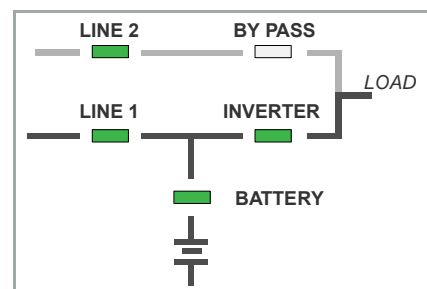
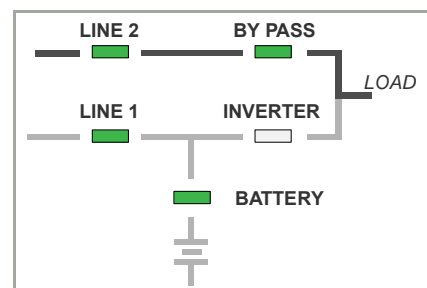
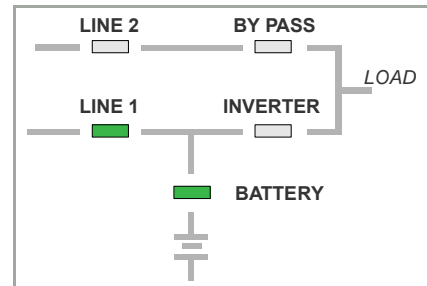

Note: This completes the procedure. The UPS is now operating in 'On-Line' mode and supply protected load power.

4.5.2 Redundant parallel module system

Module shutdown:

In a redundant parallel module system, one module can be shut down without affecting the load supply provided the remaining modules are operating.

1. Turn OFF the UPS module by pressing both ON/OFF buttons simultaneously then releasing them.
 - a) The module control panel will display LOAD OFF and SUPPLY FAILURE.
 - b) The module control panel mimic indications should be as shown here.
2. Open the module's parallel switch (IA2).
3. Open the battery fuses in the UPS cabinet or external cabinet/racks.
 - a) The BATTERY led on the module mimic should change to flashing green.
 - b) The module control panel mimic indications should be as shown here.
4. Open the mains input fuses F1 and bypass input fuses F2.
 - a) The module is now fully powered down.

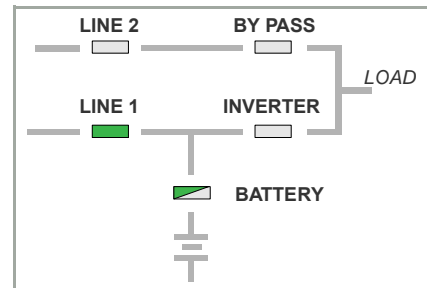
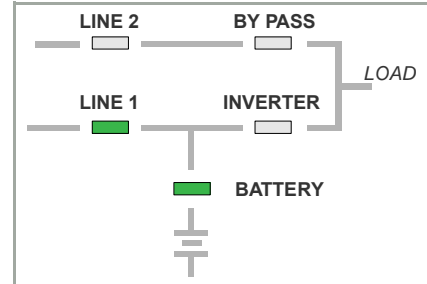

WARNING: The UPS module is still live at its input and output power terminals due to the activation of Maintenance Bypass circuit. Allow 10 minutes for the internal DC capacitors to discharge before touching any UPS internal components.

Module start-up

1. Close the mains input fuses F1 and bypass input fuses F2.
2. Close the parallel switch (IA2).
3. Close the battery fuses in the UPS cabinet or external cabinet/racks.
 - a) The module control panel will display LOAD OFF, SUPPLY FAILURE.
 - b) The BATTERY led on the module control panel mimic should change from flashing to permanent green.
 - c) The module control panel mimic indications should be as shown here.
4. Turn ON the UPS module by simultaneously pressing both ON/OFF buttons then releasing them.
 - a) The UPS module(s) will start-up over about 60 seconds.
 - b) The INVERTER will start-up and come on line (Green).
 - c) The module control panel will display LOAD PROTECTED.
 - d) The module control panel mimic indications should be as shown here.

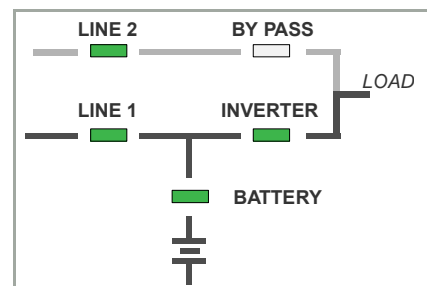
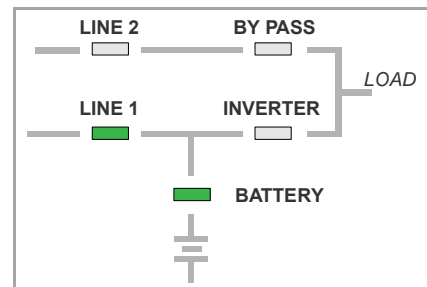

Note: This completes the procedure. The UPS is now operating in 'On-Line' mode and supply protected load power.

4: Operating Instructions with LCD Control Panel

4.5.3 Complete system shutdown

The UPS system may be shutdown completely if the load does not require power for an extended period of time. Use this procedure to totally turn off the load power and shutdown the entire UPS system.



CAUTION: This procedure will totally disconnect load power. Ensure that it is safe to lose power to all the loads connected to the UPS system before you begin this procedure.

1. Isolate all load equipment connected to the output of the UPS system by opening the fused isolators or circuit breakers in the UPS output load distribution panel.



WARNING: Perform the following steps only after the load has been fully isolated.

2. Carry out the following actions on every module in turn in a multi-module system.
3. On the UPS control panel simultaneously press both ON/OFF buttons.
 - a) The LCD panel will indicate: LOAD OFF , SUPPLY FAILURE.
4. Open the battery fuses in the UPS cabinet or external cabinet/racks.
5. Open the mains input fuses F1 and bypass input fuses F2.
6. The module is now fully powered down.
7. Open the module's parallel isolator switch (IA2).
8. Open the bypass line fuse holder F2 (IA4) and the rectifier line fuse holder F1 (IA3).
9. Open the UPS input and bypass supply isolators (or circuit breakers) on the UPS input supply distribution panel.
10. The UPS is now voltage free.



WARNING: Allow 10 minutes for the internal DC capacitors to discharge before touching the UPS internal components.

5 Operating Instructions with TFT Control Panel

5.1 Introduction

The PowerWAVE 6000 UPS system must be commissioned by a fully trained field service engineer authorised by Uninterruptible Power Supplies Ltd before it is put into use.

The commissioning engineer will:

- Connect the UPS batteries.
- Check the UPS electrical installation and operating environment.
- Check the UPS paralleling configuration settings in a multi-module system.
- Check the correct installation of any optional equipment.
- Perform a controlled UPS start-up and functionally test the system for correct operation and configuration.
- Carry out customer operator training and equipment handover.



WARNING: Uninterruptible Power Supplies Ltd. accepts no responsibility for the equipment or the safety of any personnel when operating this equipment before it has been properly commissioned.

The manufacturer's warranty is immediately invalidated if power is applied to any part of the UPS system before it has been fully commissioned and handed over to the customer.

5.1.1 Operating procedure summary

Under normal circumstances all the UPS modules in a multi-module system are running and operating in their on-line (on inverter) mode.

If a UPS module fails or is turned off in a redundant module system, the module will shut down but will not affect the remaining on-line modules, which will continue to supply the load with processed power. The failed module can then be repaired or tested off-line without affecting the remaining working modules or load supply.

If a UPS module fails or is turned off in a capacity-rated or single module system, the module will immediately shut down and the load is transferred to the unprotected static bypass supply (in ALL modules in a multi-module system).

The UPS cabinet contains a maintenance bypass switch (optional in the 400-500kVA models) which, when closed, connects the cabinet's output terminals directly to the bypass mains supply. When operating via the maintenance bypass switch, the UPS modules can be shut down for test/repair off-line as required.

Note: All the switches and control panel operations mentioned in this chapter are identified and described in chapter 2.

This chapter contains the following procedures:

- Single module initial system power-up and functional testing – Paragraph 5.2***
- Parallel system power-up and functional testing – Paragraph 5.3***
- Turning OFF/ON the UPS output (load power) – Paragraph 5.4***
- Load transfer from on-line to bypass (ECO) mode of operation – Paragraph 5.5***
- Load transfer from bypass (ECO) to on-line mode of operation – Paragraph 5.6***
- Load transfer to maintenance bypass – Paragraph 5.7***
- Complete system shutdown – Paragraph 5.8***

5.2 Single module initial system power-up and functional testing

This procedure outlines the steps taken by the commissioning engineer when energising the single module UPS system for the first time. It can also be used at any time to functionally check and restart the system following a total shutdown.



WARNING: This procedure must be carried out by a trained engineer or service agent approved by UPS Ltd.

Preliminary checks

1. Check that the UPS input/bypass supply fuses or (breakers) are open (OFF) at the mains distribution board.
2. Check that the UPS power cabling has been performed correctly and the input phase rotation is correct.
3. Check that all the UPS module parallel switch (IA2) and maintenance bypass switch (IA1) are open (OFF).
4. Ensure that the UPS mains input fuses F1/(IA3) and bypass input fuses F2/(IA4) are open.
5. Ensure that the battery fuses (breakers) fitted in the UPS cabinet or external battery cabinets/racks are open (OFF).
6. Check that the parallel configuration DIP switches are set correctly (see paragraph 3.12.2).

Module configuration

1. Close the UPS input/bypass supply fuses or (breakers) at the mains distribution board.
2. On the UPS module close the mains input fuses F1/(IA3) and bypass input fuses F2/(IA4).
 - a) The graphical display will start-up automatically.
 - b) The status Load off will be indicated in the display header.
 - c) The mimic screen will indicate the input to the rectifier as green, but the rectifier/booster and inverter will be inhibited (red) as shown.

Note: that the parallel isolator IA2 is always shown in green and not monitored in a single module system.

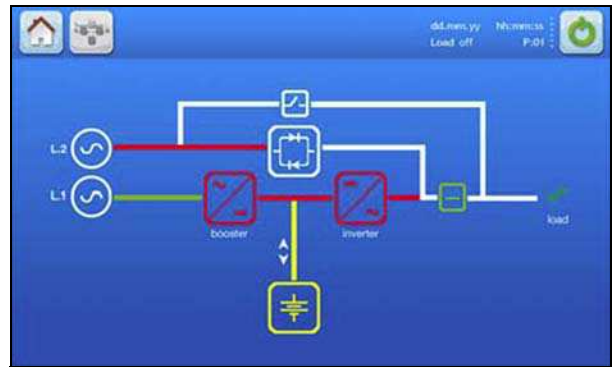

Key Point: During commissioning, the commissioning engineer can set/check various module configuration data at this point – e.g. Set Time, Date, Module ID etc. This requires access to a password protected menu area and must be carried out only by an approved engineer.

Rectifier/booster and inverter checks

3. Press the On/Off icon located on the display header then select the green On/Off icon to confirm that you want to turn ON the UPS.

Shouldn't the booster be green?

Note: There will be no power at the UPS output as the parallel switch (IA2) is still open.

- a) The triangular warning icon will appear on the display header and a Parallel switch open message will be displayed.
- b) The static bypass will turn on (green).
- c) The status Load not prot will be indicated in the display header.
- d) The mimic diagram should appear as shown here.

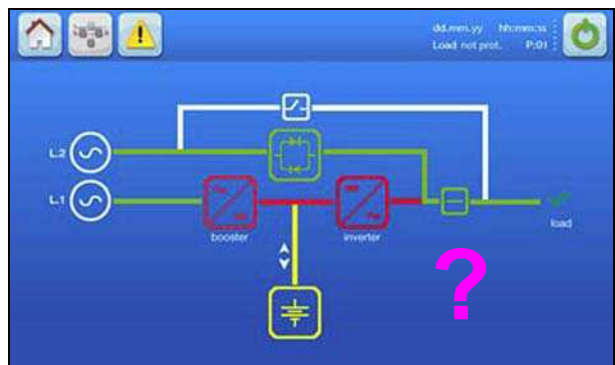

5: Operating Instructions with TFT Control Panel

4. Press the Home screen icon on the display header.
5. From the Home screen press the Command icon, then select Load to inverter.
 - a) The rectifier/booster and inverter will turn on (green).
 - b) The static bypass will turn off.
 - c) The load will be transferred to the inverter (although the parallel isolator (IA2) is still open and there will be no power at the UPS output terminals.
 - d) The status Load protected will be indicated in the display header.
 - e) The mimic diagram should appear as shown here.

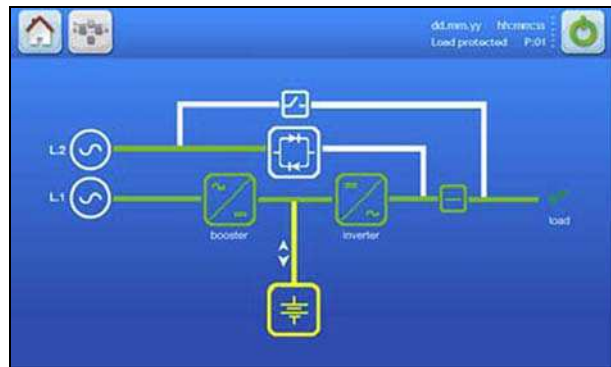

6. From the Home screen press the Measures icon, then scroll through the measurements menu and check that the module's input and output supply indications are correct.

Battery checks

7. Check the battery voltage and polarity at the live side of the battery fuses (breaker) located in the UPS cabinet or external cabinet/rack with the fuses (breaker) still open.
8. If an external battery cabinet (or rack) is used, check the cabling between the UPS cabinet and battery cabinet (rack) to determine that it is safe to connect the battery.
9. Close the battery fuses (breakers) fitted in the UPS cabinet or external battery cabinets/racks.
10. Press the On/Off icon located on the display header and select the red On/Off icon to confirm that you want to turn OFF the UPS.
11. Close the parallel isolator (IA2).
 - a) A Parallel switch closed warning will appear.
12. Press the On/Off icon located on the display header and select the green On/Off icon to confirm that you want to turn ON the UPS.
 - a) The UPS output terminals will be live.
 - b) The battery will indicate it is connected (green) and on charge.
 - c) The status Load protected will be indicated in the display header.
 - d) The mimic diagram should appear as shown here.

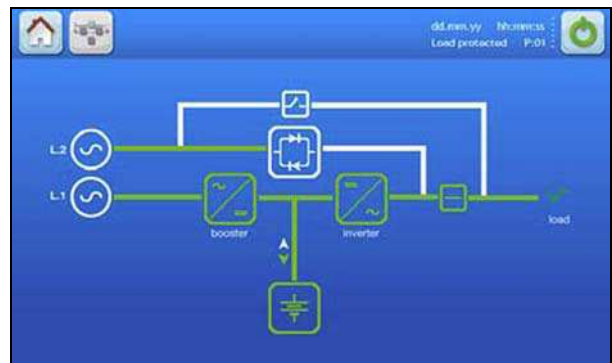

Maintenance bypass checks

13. Press the Home screen icon on the display header.
14. From the Home screen press the Command icon, then select Load to bypass.
15. Close the maintenance bypass switch (IA1).
 - a) The triangular warning icon will appear on the display header and a Manual bypass is closed warning will be displayed.
 - b) The inverter will be inhibited and shown in red.
 - c) The status Load not prot will be indicated in the display header.
 - d) The mimic diagram should appear as shown here.

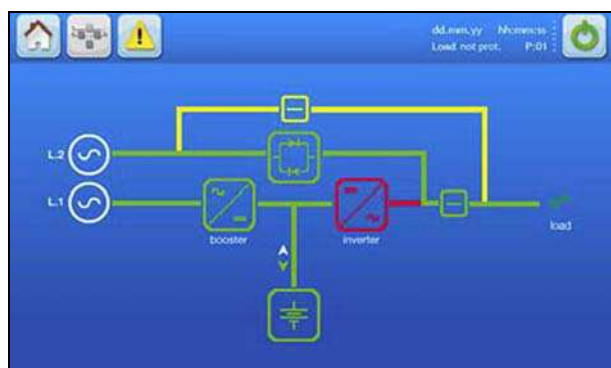

16. Open the maintenance bypass switch (IA1).
 - a) A Manual bypass is open warning will be displayed.
 - b) The status Load not prot will be indicated in the display header.
 - c) The static bypass will be ON (green) and the inverter will remain inhibited (red).
 - d) The mimic diagram should appear as shown here.

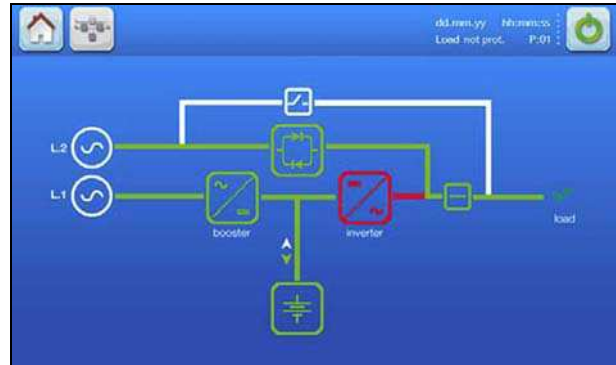

On-line operation

17. Press the Home screen icon on the display header.
18. From the Home screen press the Command icon, then select Load to Inverter.
 - e) The static bypass will turn off.
 - f) The load will be transferred to the inverter (green).
 - g) The status Load protected will be indicated in the display header.
 - h) The mimic diagram should appear as shown here.
19. This completes the UPS functional checks.

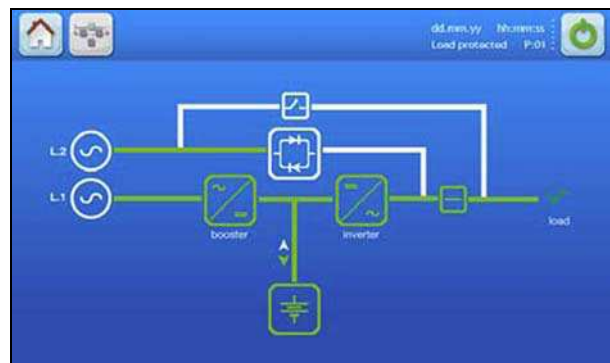

WARNING: The next action will apply mains power to the load equipment. Check that the load is ready to receive power and that it is safe to do so before you continue.

20. Close the fuses/isolators on the output (load) distribution board to connect the load equipment to the UPS output.
21. From the Home screen press the Measures icon, then scroll through the measurements menu and check that the module's input and output supply indications are correct.

5.3 Parallel system power-up and functional testing

This procedure outlines the steps taken by the commissioning engineer when energising the single module UPS system for the first time. It can also be used to functionally check and restart the system following a total shutdown.



WARNING: This procedure must be carried out by a trained engineer or service agent approved by UPS Ltd.

Preliminary checks (on ALL modules)

1. Check that the UPS input/bypass supply fuses or (breakers) are open (OFF) at the mains distribution board.
2. Check that the UPS power cabling has been performed correctly and the input phase rotation is correct.
3. Check that all the UPS module parallel switches (IA2) and maintenance bypass switches (IA1) are open (OFF).
4. Ensure that the UPS mains input fuses F1/(IA3) and bypass input fuses F2/(IA4) are open.
5. Ensure that the battery fuses (breakers) fitted in the UPS cabinet or external battery cabinets/racks are open (OFF).
6. Check that the parallel configuration DIP switches are set correctly in all cabinets (see paragraph 3.12.2).



WARNING: Initially, all UPS modules must be totally powered down with their parallel isolator (IA2) open.

5: Operating Instructions with TFT Control Panel

AUTHOR'S NOTE: The procedure in the NewWave manual assumes that all the modules are configured with their ID/ parallel chain position etc. Although the instructions for setting this on the parallel DIP switch is contained in paragraph 3.12.2 is it not necessary to replicate this in the Module software? in which case we need to include instructions for doing this at the start of this procedure.

Module configuration (on each module in turn)

1. Close the UPS input/bypass supply fuses or (breakers) at the mains distribution board.
2. On the UPS module close the mains input fuses F1/(IA3) and bypass input fuses F2/(IA4).
 - a) The graphical display will start-up automatically.
 - b) The status Load not prot will be indicated in the display header.
 - c) The mimic screen will indicate the input to the rectifier as green, but the rectifier/booster and inverter will be inhibited (red) as shown.
 - d) The parallel isolator IA2 is shown open (red).

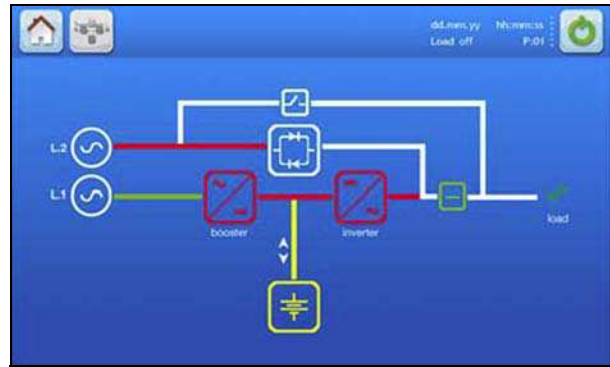

Key Point: During commissioning, the commissioning engineer can set-up the module's configuration data at this point – e.g. Set Time, Date, Module ID etc. This requires access to a password protected menu area and must be carried out only by an approved engineer.

3. Open the UPS module close the mains input fuses F1/(IA3) and bypass input fuses F2/(IA4).
4. Repeat the above procedure on ALL modules until the module configuration has been checked/set-up on each one. Then continue with the procedure below.

Rectifier/Booster, Inverter and paralleling checks

Note: At the start of this check procedure all UPS modules should be OFF with their output isolator (IA2) open.

On the LAST module in the system (e.g. Module 10 in a ten module system)

5. Close the mains input fuses F1/(IA3) and bypass input fuses F2/(IA4).
6. Close the parallel isolator (IA2).
 - a) A Parallel switch closed warning will be displayed.
7. Press the On/Off icon located on the display header then select the green On/Off icon to confirm that you want to turn ON the UPS.
 - a) A Parallel switch closed warning will be displayed.
 - b) The static bypass will turn on (green).
 - c) The status Load not prot will be indicated in the display header.

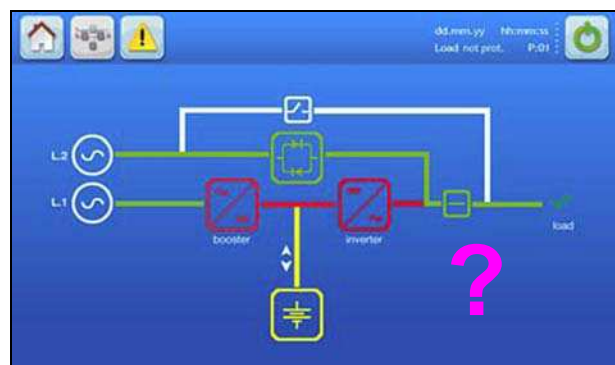

8. Press the Home screen icon on the display header.
9. From the Home screen press the Command icon, then select Load to inverter.
 - a) The rectifier/booster and inverter will turn on (green).
 - b) The static bypass will turn off.
 - c) The load will be transferred to the inverter (although the parallel isolator (IA2) is still open and there will be no power at the UPS output terminals.
 - d) The status Load protected will be indicated in the display header.
 - e) The mimic diagram should appear as shown here.

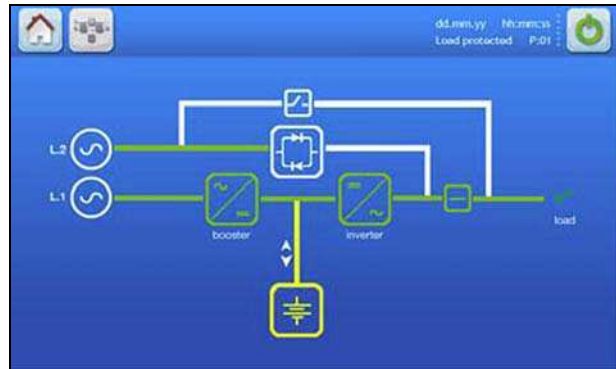

10. From the Home screen press the Measures icon, then scroll through the measurements menu and check that the module's input and output supply indications are correct.

Battery checks

11. Open the parallel isolator (IA2).
12. Check the battery voltage and polarity at the live side of the battery fuses (breaker) located in the UPS cabinet or external cabinet/rack with the fuses (breaker) still open.
13. If an external battery cabinet (or rack) is used, check the cabling between the UPS cabinet and battery cabinet (rack) to determine that it is safe to connect the battery.
14. Close the battery fuses (breakers) fitted in the UPS cabinet or external battery cabinets/racks.
15. Press the On/Off icon located on the display header and select the red On/Off icon to confirm that you want to turn OFF the UPS.
16. Close the parallel isolator (IA2).
 - a) A Parallel switch closed warning will appear.
17. Press the On/Off icon located on the display header and select the green On/Off icon to confirm that you want to turn ON the UPS.
 - a) The battery will indicate it is connected (green) and on charge.
 - b) The status Load protected will be indicated in the display header.
 - c) The mimic diagram should appear as shown here.
(NOT YET SELECTED LOAD TO INVERTER!?)

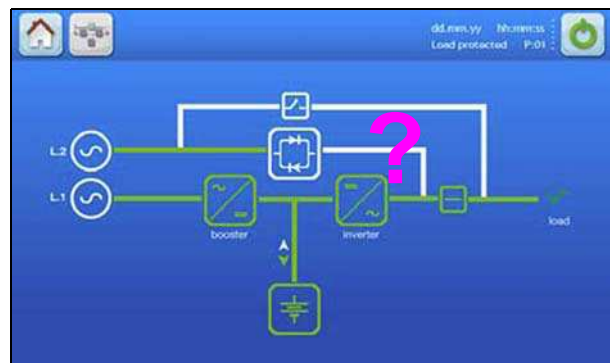

18. The event message UPS now is the master will appear.
19. Leave the last module running and repeat steps 5 to 18 on the next-from-last module (e.g. Module 9) and check that when you reach step 18 the last-but-one module shows the event message UPS now is the master and the event message in the last module (module 10) indicates UPS is now the slave.
20. Repeat the above start-up operation on each module in sequence finishing with the module configured as Module 1, and check at each stage that the newly started module becomes the master and the already running modules the slaves.

5: Operating Instructions with TFT Control Panel

21. At the end of the start-up sequence ALL modules should be operating on-line (in parallel) and the mimic indication should be as shown here.

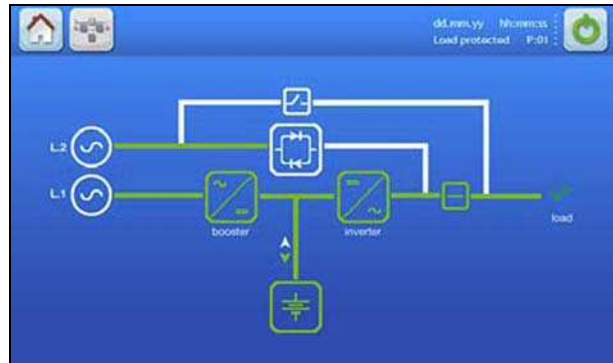

Maintenance bypass checks

22. On any module in the system, press the Home screen icon on the display header.
23. From the Home screen press the Command icon, then select Load to bypass.
24. On module 1, close the maintenance bypass switch (IA1). On ALL modules:
- The triangular warning icon will appear on the display header and a Manual bypass is closed warning will be displayed.
 - The inverter will be inhibited and shown in red.
 - The status Load not prot will be indicated in the display header.
 - The mimic diagram should appear as shown here.
25. On module 1, open the maintenance bypass switch (IA1).
- A Manual bypass is open warning will be displayed.
 - The status Load not prot will be indicated in the display header.
 - The static bypass will be ON (green) and the inverter will remain inhibited (red).
 - The mimic diagram should appear as shown here.

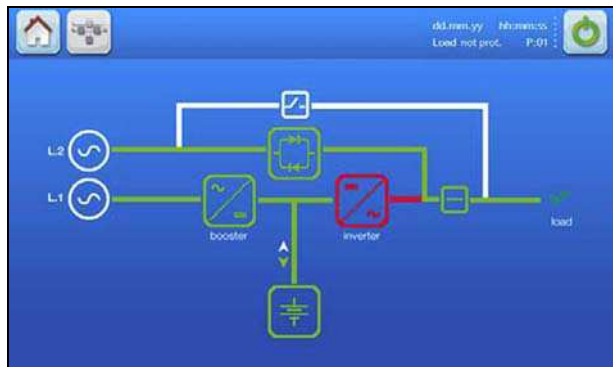
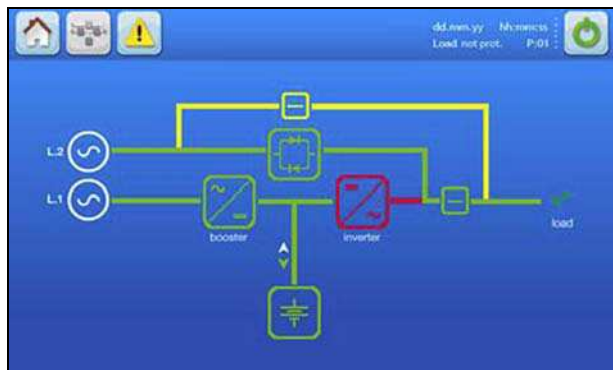

On-line operation

26. On ANY module, press the Home screen icon on the display header.
27. From the Home screen press the Command icon, then select Load to Inverter.
- The static bypass will turn off.
 - The load will be transferred to the inverter (green).
 - The status Load protected will be indicated in the display header.
 - The mimic diagram should appear as shown here.
28. This completes the UPS functional checks.

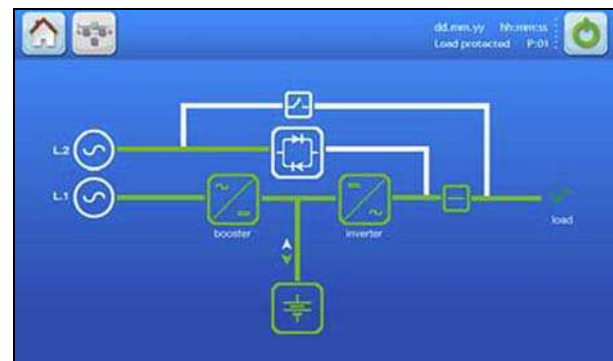



WARNING: The next action will apply mains power to the load equipment. Check that the load is ready to receive power and that it is safe to do so before you continue.

29. Close the fuses/isolators on the output (load) distribution board to connect the load equipment to the UPS output.
30. From the Home screen press the Measures icon, then scroll through the measurements menu and check that the module's input and output supply indications are correct.

5.4 Turning OFF/ON the UPS output (load power)

5.4.1 Turning OFF the UPS output



WARNING: The next action will remove mains power to the load equipment. Check with the load user that it is safe to do so before you continue.

This procedure assumes that the UPS is initially operating normally in its on-line mode.

1. Press the On/Off icon located on the display header and select the red On/Off icon to confirm that you want to turn OFF the UPS.
 - a) The UPS output terminals will be unpowered.
 - b) The rectifier/booster and inverter will be turned off.
 - c) The battery will no longer be charged.
 - d) The status Load off will be indicated in the display header.
 - e) The mimic diagram should appear as shown here.

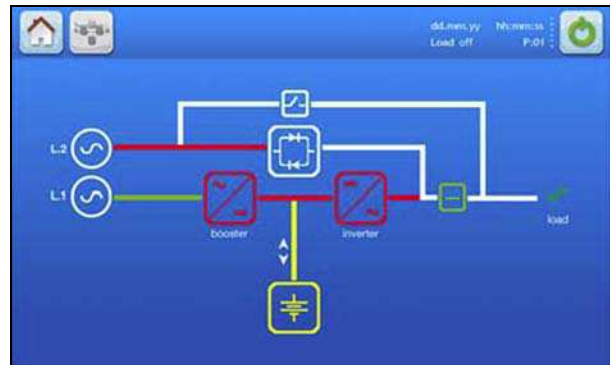

Note: In a parallel system the remaining on-line modules will transfer to bypass when the system redundancy has been exceeded.

2. In a parallel module system repeat the above step in ALL modules.

Note: The graphic shown is for a single module system. In a parallel module system the parallel output isolator (IA2) will be shown open and red in colour.

5.4.2 Turning ON the UPS output



WARNING: The next action will apply mains power to the load equipment. Check with the load user that it is safe to do so before you continue.

This procedure assumes that the UPS is initially operating but its output turned off.

1. Press the On/Off icon located on the display header then select the green On/Off icon to confirm that you want to turn ON the UPS.
 - a) The static bypass will turn on (green).
 - b) The status Load not prot will be indicated in the display header.
 - c) The mimic diagram should appear as shown here.
2. In a parallel module system repeat the above step on ALL modules.

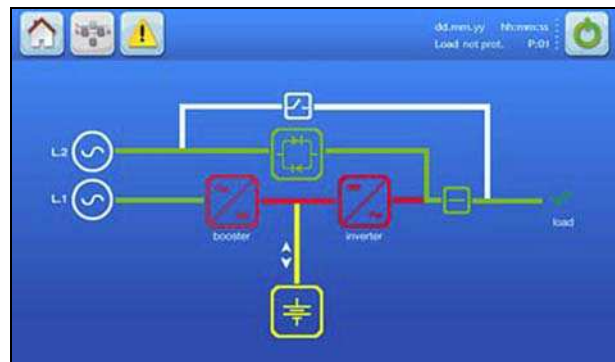

5: Operating Instructions with TFT Control Panel

3. When ALL the modules in a parallel system are operating on-bypass, press the Home screen icon on the display header.
4. From the Home screen press the Command icon, then select Load to inverter.
 - a) The rectifier/booster and inverter will turn on (green).
 - b) The static bypass will turn off.
 - c) The load will be transferred to the inverter.
 - d) The status Load protected will be indicated in the display header.
 - e) The mimic diagram should appear as shown here.

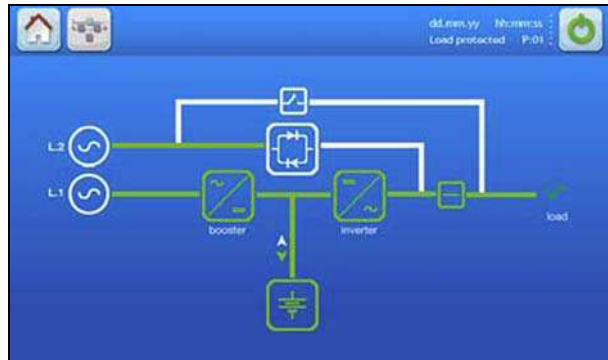

The UPS is now operating in its normal on-line mode.

5.5 Load transfer from on-line to bypass (ECO) mode of operation

If the load does not need the highest degree of protection you can transfer the load to the UPS bypass supply. When operating on-bypass the load is not protected against supply aberrations but the UPS system efficiency is slightly greater than when operating in its normal on-line mode. For this reason, this mode of operation is also known as the “ECO” mode.



WARNING: If the UPS bypass supply fails when operating in this mode, the load will experience a brief power break while the UPS transfers its output to inverter.

1. This procedure assumes the UPS is initially running in its normal (on-line) mode.
 - a) The load is initially on inverter.
 - b) The status Load protected will be indicated in the display header.
 - c) The mimic diagram should appear as shown here.

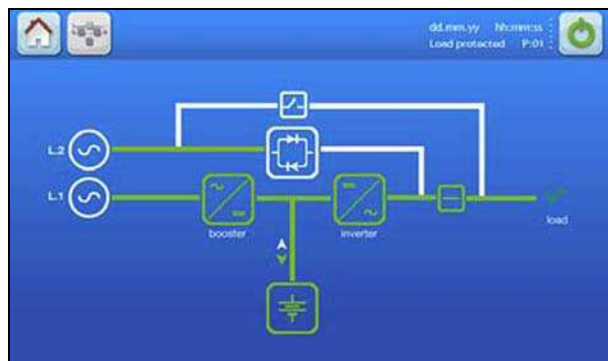

2. On any module in the system, press the Home screen icon on the display header.
3. From the Home screen press the Command icon, then select Load to bypass.
4. On ALL modules in a parallel system:
 - a) The load is transferred to the bypass supply.
 - b) The inverter will be inhibited (red)
 - c) The status Load not prot will be indicated in the display header.
 - d) The mimic diagram should appear as shown here.

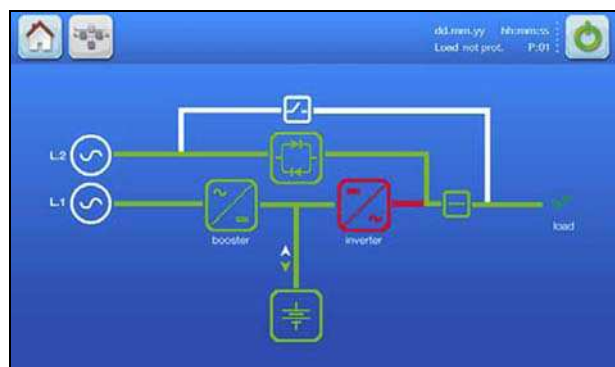

The load is now powered from the UPS bypass supply and the UPS is operating in the ECO mode.

5.6 Load transfer from bypass (ECO) to on-line mode of operation

1. This procedure assumes the UPS is initially running in its bypass (ECO) mode.
 - a) The load is transferred to the bypass supply.
 - b) The inverter will be inhibited (red)
 - c) The status Load not prot will be indicated in the display header.
 - d) The mimic diagram should appear as shown here.

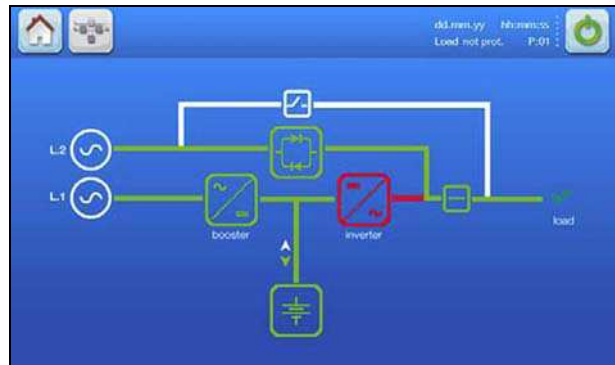

2. On any module in the system, press the Home screen icon on the display header.
3. From the Home screen press the Command icon, then select Load to Inverter.
 - a) The load is transferred to inverter.
 - b) The status Load protected will be indicated in the display header.
 - c) The mimic diagram should appear as shown here.

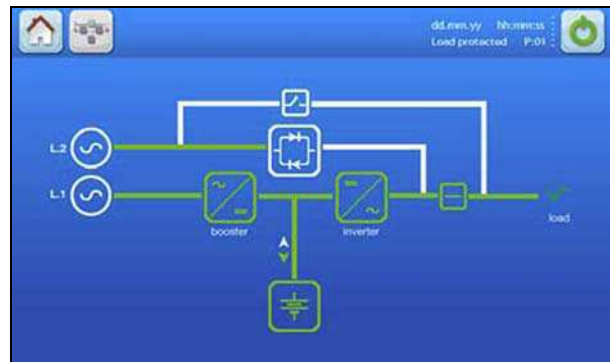

The UPS is now operating in the on-line mode and the load is fully protected.

5.7 Load transfer to maintenance bypass

The load can be transferred to the maintenance bypass supply if it is necessary to shutdown the UPS for service or repair.

Note: This is not required for normal scheduled maintenance processes.



WARNING: This procedure must be carried out by a trained engineer or service agent approved by UPS Ltd.

1. This procedure assumes the UPS is initially running in its normal (on-line) mode.
 - a) The load is initially on inverter.
 - b) The status Load protected will be indicated in the display header.
 - c) The mimic diagram should appear as shown here.

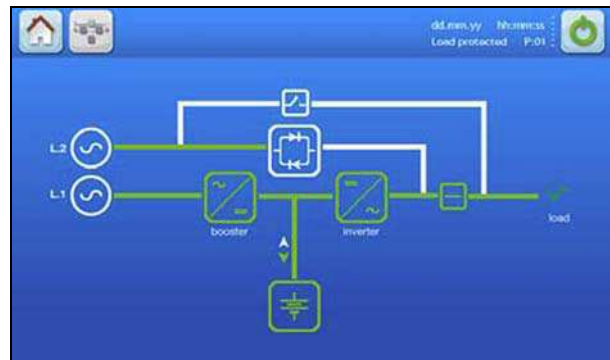

5: Operating Instructions with TFT Control Panel

2. On any module in the system, press the Home screen icon on the display header.
3. From the Home screen press the Command icon, then select Load to bypass.
4. On ALL modules in a parallel system:
 - a) The load is transferred to the bypass supply.
 - b) The inverter will be inhibited (red)
 - c) The status Load not prot will be indicated in the display header.
 - d) The mimic diagram should appear as shown here.

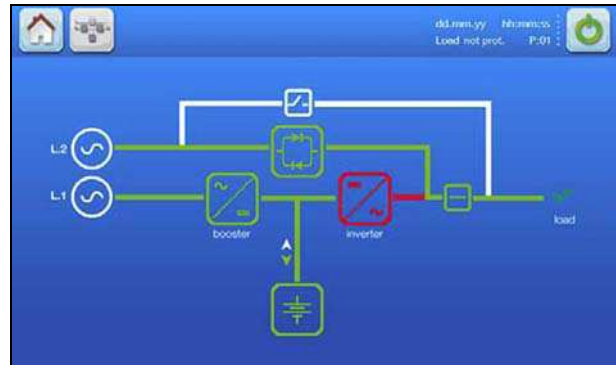

5. Close the maintenance bypass switch (IA1) On ALL modules in a parallel system.
 - a) The triangular warning icon will appear on the display header and a Manual bypass is closed warning will be displayed.
 - b) The inverter will be inhibited and shown in red.
 - c) The status Load not prot will be indicated in the display header.
 - d) The mimic diagram should appear as shown here.

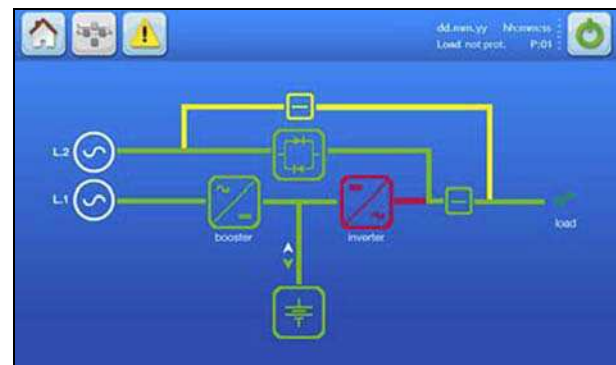

6. To fully shut down the UPS for safe internal access:
 - a) Open the UPS module parallel switches (IA2).
 - b) Open the input mains fuses F1/(IA3).
 - c) Open the bypass mains fuses F3/(IA4).
 - d) Open the battery mains fuses/isolators.



WARNING: UPS is still live at it's input/bypass power terminals and output terminals. Do not isolate the UPS bypass terminal from the external UPS supply distribution board otherwise you will lose the load supply.

5.8 Complete system shutdown



WARNING: The next action will remove mains power to the load equipment. Check with the load user that it is safe to do so before you continue.



WARNING: This procedure must be carried out by a trained engineer or service agent approved by UPS Ltd.

If the load does not require power for an extended period of time the entire UPS system can be shut down as follows:

1. Transfer the load to the maintenance bypass supply as described in Paragraph 5.7.
2. Fully shut down the UPS as follows:
 - a) Open the UPS module parallel switches (IA2).
 - b) Open the input mains fuses F1/(IA3).
 - c) Open the bypass mains fuses F3/(IA4).
 - d) Open the battery mains fuses/isolators.
 - e) Open the power fuses/isolators at the UPS input and output distribution boards.

6 Maintenance

6.1 Introduction



WARNING: The procedures described in this chapter must be performed by an authorised electrician who has received the appropriate level of training on this UPS system.

As there are no user-serviceable parts contained within the UPS the maintenance requirements are minimal. However, to maximise the useful working life and reliability of the UPS and its batteries we recommend that the UPS system and batteries are inspected and checked for calibration on a 6 monthly basis as part of a preventative maintenance schedule.

6.2 User responsibilities

The operator should inspect the UPS equipment daily to ensure that the environment in which the UPS operates is kept cool and dust free at all times, and that the operating temperature and humidity is within the limits given in the specifications chapter of this manual.

Any active alarm or status indication that indicates that the UPS is not functioning correctly should be dealt with immediately by referring to the troubleshooting chapter of this manual or contacting the manufacture's service desk.

6.3 Routine maintenance

When the UPS is commissioned, the commissioning engineer will attach a service record book to the front of the UPS which will be used to log the future service history of the UPS. To ensure optimum UPS operation and continuous, efficient protection of the connected load, we recommend that the system's operating parameters are checked and logged every six months, and recalibrated where necessary.



WARNING: When working inside the UPS cabinet there is a risk of exposure to potentially lethal AC and DC voltages. All work that requires internal cabinet access must be carried out by trained personnel only.

During a preventative maintenance inspection the field service engineer will check the following:

- Site/environment conditions.
- Integrity of electrical installation.
- Cooling airflow.
- Rectifier /booster operation and calibration.
- Inverter operation and calibration.
- Static switch operation.
- Battery status.
- Load characteristics.
- Integrity of alarm and monitoring systems.
- Correct operation of all installed options.

Preventative maintenance inspections form an integral part of all Extended Warranty Agreements (maintenance contracts) offered by Uninterruptible Power Supplies Ltd.

For further details on Extended Warranty Agreements see Chapter 2.

6.4 Battery testing

A battery facility test can be selected from the UPS control panel and takes approximately 3 minutes to complete.

The test, which can be carried out independent of the operating mode (off-line or on-line) and whether or not the load is connected, should be undertaken only if there are no alarm conditions and the battery is initially fully charged.

7 Troubleshooting

7.1 Alarms

AUTHORS NOTE: List of alarms would be useful.

Various UPS operating parameter and conditions are monitored and will initiate an alarm or warning notification on the UPS control panel if an error is detected. In the event that an alarm occurs you should:

1. Silence the audible warning.
2. Identify the alarm by inspecting the UPS module's 'event' register.
3. Interpret the cause of the alarm (see below) and seek assistance from your nearest service centre if the cause of the alarm is beyond simple rectification.

7.2 LCD Control panel

The LCD Control panel is described in Paragraph 2.5.

If an alarm condition occurs the red ALARM led will flash accompanied by an audible warning:

1. Cancel the audible warning by pressing the RESET button. If the alarmed condition was transient the audible warning will stop and the red warning light will extinguish. If the red warning remains ON it indicates that the cause of the alarm is still present and must be investigated.
2. Investigate the cause of the alarm by making a note of the EVENT LOG, which is accessed from the MAIN MENU – this will present a list of time-stamped events that took place preceding the detected alarm.
3. Access the MEASUREMENTS screen from the MAIN MENU and note the value of the UPS input/output/battery parameters etc.
4. Refer to the troubleshooting table below for possible fault resolutions.

7.3 TFT Control panel

The TFT Control panel is described in Paragraph 2.6.

If an alarm condition occurs the red amber WARNING symbol will be displayed in the control panel header bar accompanied by an audible warning:

1. Cancel the audible warning by pressing the WARNING symbol. This will silence the audible warning and open the EVENTS screen, which will present a list of time-stamped events that took place preceding the detected alarm.
2. Investigate the cause of the alarm by making a note of the EVENTS.
3. Pressing the Home screen icon on the display header bar then selecting Measures. This will open the metering screens from which you can observe and note the value of the UPS input/output/battery parameters etc.
4. Refer to the troubleshooting table below for possible fault resolutions.

7.4 Troubleshooting table

ALARM CONDITION	MEANING	SUGGESTED SOLUTION
UPS FAULT	There is a fault in the UPS and therefore normal operation cannot be guaranteed	Call the authorised service centre for assistance.
MAINS BYP/RECT FAULT	Mains power supply is outside prescribed tolerance	The input power to UPS is too low or missing. If site power appears to be OK, check the input circuit breakers etc. supplying the UPS.
OUTPUT SHORT	There is a short circuit at the output of UPS (on load side)	Check all output connections and repair as required.
OVERLOAD	Load exceeds the UPS rated power	Identify which piece of equipment is causing the overload and remove it from the UPS. Do not connect laser printers, photocopiers, electric heaters, kettles etc. to the UPS.
OVERTEMPERATURE	UPS temperature has exceeded the allowed value	Check the ambient temperature of the UPS is less than 30° C. If the ambient temperature is normal call the authorised service centre for assistance.
BATTERY CHARGER OFF	The attached battery and the battery charger set-up do not correspond or battery charger fault	Call the authorised service centre for assistance.
INVERTER FAULT	Inverter is faulty.	Call the authorised service centre for assistance.
SYNCHRON FAULT	The inverter and mains are not synchronised.	The frequency of the input voltage to the UPS is outside operational limits and the UPS static bypass has been temporarily disabled.
BATTERY IN DISCHARGE	Battery is near end of autonomy	Shutdown load connected to UPS before the UPS switches itself off to protect its batteries
MANUAL BYP IS CLOSED	Maintenance bypass closed. Load supplied by mains	This alarm is only displayed if the UPS is on maintenance bypass

7.5 Contacting service

Uninterruptible Power Supplies Limited has a service department dedicated to providing routine maintenance and emergency service cover for your UPS. If you have any queries regarding your UPS please contact us.

Uninterruptible Power Supplies Ltd.
Woodgate
Bartley Wood Business Park
Hook
Hampshire
RG27 9XA

Tel: 01256 386700
0800 731 3269 (24 Hr.)

Fax: 01256 386701

Email: service@upspower.co.uk

We recommend that your UPS is protected by an extended warranty agreement (see Chapter 2 for details). These agreements assist us in caring for your UPS, ensuring that it is well maintained and attended to promptly should any problems occur.

8 Options

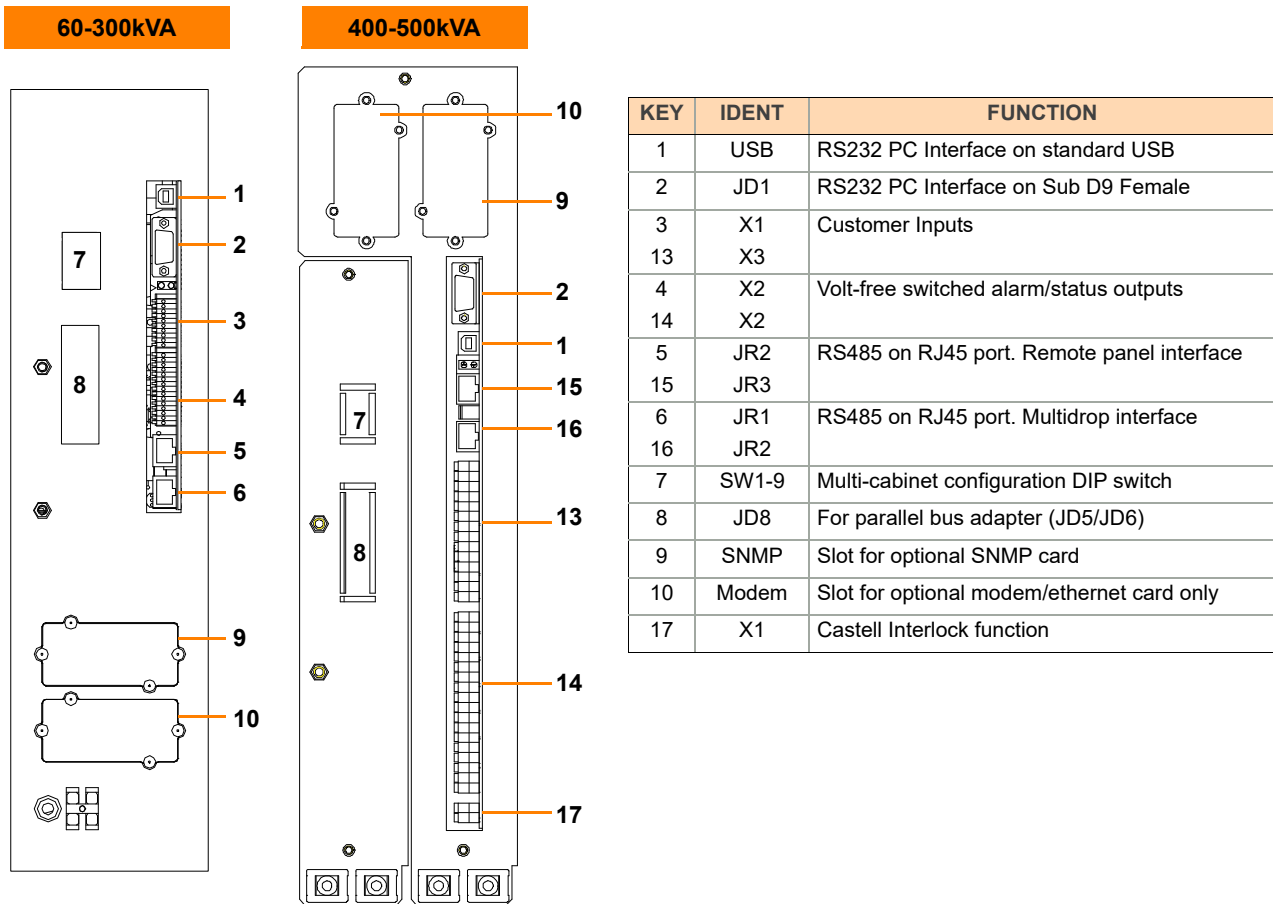

Figure 8.1 UPS Interfacing connectors

8.1 Introduction

Each UPS is fitted with a communication interface board, as shown in Figure 8.1, which enables various external monitoring and control applications to be connected to the UPS system to satisfy particular site requirements. These interfaces are described below.

- RS232 Computer serial interface – USB & JD1 (see paragraph 8.2)
- RS485 Interface for multidrop – JR1 (JR2 for 400-500kVA) (see paragraph 8.3)
- Dry port customer interface – X1, X2 (X1, X2, X3 for 400-500kVA) (see paragraph 8.4)
- SNMP/ Modem slots for remote monitoring/control – (see paragraph 8.5)

8.2 Serial RS232 Computer interface – USB & JD1 (Smart Port)

A serial RS 232 interface is available through a standard 9-pin D-Type female socket (JD1) or USB port to provide an intelligent RS 232 serial port which allows the UPS to be connected to a computer.

When used in conjunction with the optional WAVEMON software, this port allows the connected computer to continuously monitor the input mains voltage and UPS status, and display a message in the event of any UPS system changes.

Figure 8.2 shows the cable wiring suitable for PC's with a 9 pin or 25 pin serial port respectively. Note that the maximum length for the interconnecting RS232 cable is 15m.

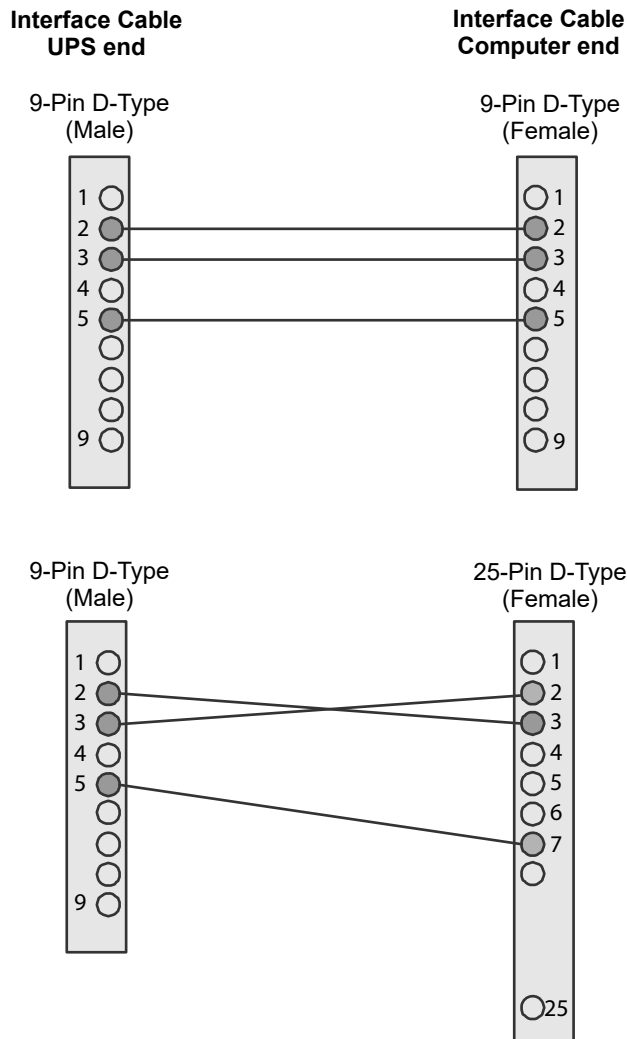

Figure 8.2 Connector Cable - PC Serial Port

8.3 RS485 Interface for multidrop – JR1 (JR2 for 400-500kVA)

Using the Multidrop connection kit, the computer interface (JR1) (JR2 for 400-500kVA) is an intelligent RS485 serial port that allows a computer to access information from all modules connected in a parallel system. The retrieved data can be used to display the system operating parameters and status.

8.4 Dry ports customer interface (X1, X1, X3)

Customer I/O interface facilities are made to Phoenix spring terminal blocks (cable 0.2mm² to 1.5mm²) annotated X1, X2 and X3. All voltage-free contacts are rated at 250Vac/8A, 30Vdc/8A, 110Vdc/0.3A, 220Vdc/0.12A

8.4.1 60-300kVA Model interface connections

	Terminal	Contact	Signal	Display	Function
X1	X1/10	Gnd	Gnd		+12Vdc Power source (max 200mA)
	X1/9	In	+12Vdc		
	X1/8	Gnd	Gnd		REMOTE SHUTDOWN (Do not remove the factory-fitted bridge if this feature is not used)
	X1/7	In	+12Vdc		
	X1/6	Gnd	Gnd		Battery Temperature Sensing (If connected this input is battery temperature dependent)
	X1/5	In	+3.3V		
	X1/4	Gnd	Gnd		Customer Specific Input (1) (Function on request))
	X1/3	In	+12Vdc		
	X1/2	Out	Gnd		Customer Specific Input (2) (Default NC = Generator on line)
	X1/1	Gnd	+12Vdc		
X2	X2/15	Com	Alarm	COMMON ALARM	Common
	X2/14	NC			No Alarm Condition
	X2/13	NO			Common (System) Alarm active
	X2/12	Com	Status	LOAD ON MAINS	Common
	X2/11	NC			Load NOT On Bypass
	X2/10	NO			Load on Bypass (Mains) active
	X2/9	Com	Alarm	BATT LOW	Common
	X2/8	NC			Battery OK
	X2/7	NO			Battery Low active
	X2/6	Com	Status	LOAD ON INV	Common
	X2/5	NC			Load not On Inverter
	X2/4	NO			Load on Inverter active
	X2/3	Com	Alarm	MAINS OK	Common
	X2/2	NC			Mains Failure
	X2/1	NO			Mains Present

8.4.2 400-500kVA Customer interface connections

	Terminal	Contact	Signal	Display	Function
X3	X3/14	Gnd	Gnd		Battery Temperature Sensing (If connected this input is battery temperature dependent)
	X3/13	In	+3.3V		
	X3/12	Gnd	Gnd	GENERATOR	Customer Specific Input (1) (Default NC = Generator on line)
	X3/11	In	+12V	OPER ON	
	X3/10	Gnd	Gnd	EXTERNAL O/P BREAKER	When used, both the external output breaker and internal IA2 have to be either open or closed in order to isolate or connect the UPS. Display: PARALLEL_SW_OPEN or PARALLEL_SW_CLOSED
	X3/9	In	+12V		
	X3/8	Gnd	Gnd	EXT MAN BYP	External Manual Bypass (Default NC = External bypass closed)
	X3/7	In	+12V		
	X3/6	Out	+12V		+12Vdc Power source (max 200mA)
	X3/5	Gnd	Gnd		
	X3/4	Gnd	Gnd	REMOTE SHUT- DOWN	RSD Remote Shut Down Leave jumper JP5 in place if no Remote Shut Down input is connected
	X3/3	In	+12V		
	X3/2	–		REMOTE SHUT- DOWN	RSD Remote Shut Down (For external switch) Max 250Vac/8A, 30Vdc/8A, 110Vdc/0.3A, 220Vdc/0.12A
X3/1	–				
X2	X2/18	Com			Common
	X2/17	NC			Auxiliary NO
	X2/16	NO			Auxiliary NC
	X2/15	Com	Alarm	COMMON ALARM	Common
	X2/14	NC			No Alarm Condition
	X2/13	NO			Common (System) Alarm active
	X2/12	Com	Status	LOAD ON MAINS	Common
	X2/11	NC			Load NOT On Bypass
	X2/10	NO			Load on Bypass (Mains) active
	X2/9	Com	Alarm	BATT LOW	Common
	X2/8	NC			Battery OK
	X2/7	NO			Battery Low active
	X2/6	Com	Status	LOAD ON INV	Common
	X2/5	NC			Load not On Inverter
	X2/4	NO			Load on Inverter active
	X2/3	Com	Alarm	MAINS OK	Common
	X2/2	NC			Mains Failure
X2/1	NO	Mains Present			
X1	X1/2	230Vac	–	EXT MAN BYP	Castell Interlock Function
	X1/1	N	–		External Manual Bypass closed (230Vac 2AT)

8.4.3 Remote emergency stop option

On a standard UPS the remote emergency stop function is disabled; and if this option is required it must be activated by a hardware code on the SETUP SERVICE menu. Please contact your distributor to enable this operation.

The remote stop facility comprises a normally-closed circuit connected between terminal X1/7 and X1/8 (or X3/3 and X3/4) on the communication card located on the PowerWAVE 6000 front frame (see Figure 8.3).

It is recommended that a terminal block, with linking facilities, is installed between the UPS and the remote emergency stop button, as shown, in order to allow the removal, maintenance or testing of the remote emergency stop circuit without disturbing the normal UPS operation.

1. Use a screened cable with 1 pair (section of wires 0.6 mm²) and maximum length of 100 m.
2. Connect the cable as shown in Figure 8.3.

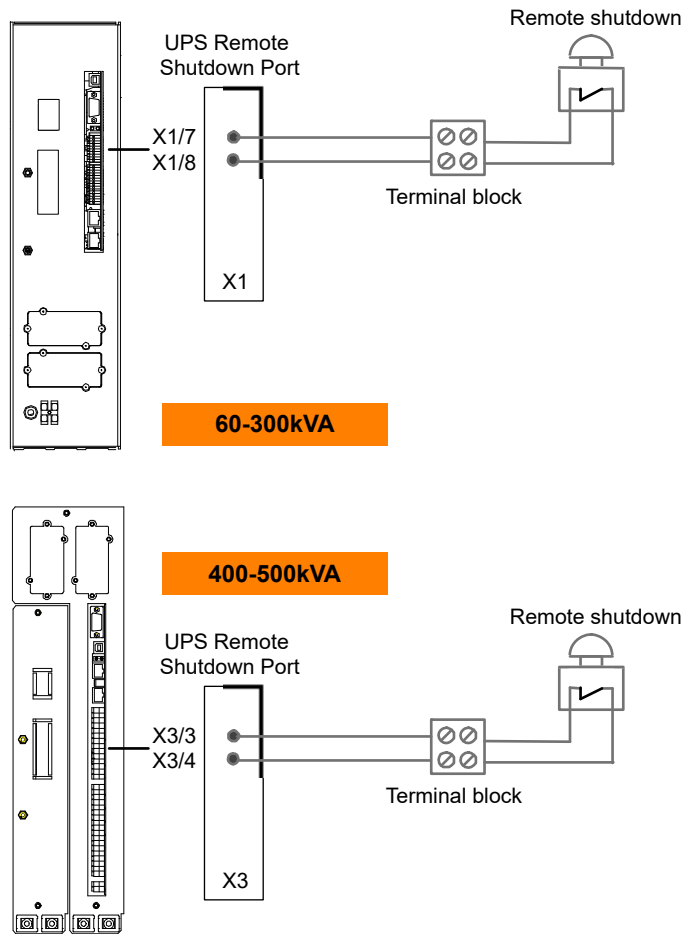

Figure 8.3 Remote emergency stop cabling

8.4.4 Generator ON facilities

The generator ON facility must use a normally-open contact which closes when a standby generator is running and supplying the UPS input power. When used, this facility enables the option to inhibit the operation of the battery charger and/or static bypass.

1. Use a screened cable with 1 pair (section of wires 0.6 mm²) and maximum length of 100 m.
2. Connect the cable as shown in Figure 8.4.

8.4.5 SNMP Card slots

Simple Network Management Protocol (SNMP) is a world-wide, standardised communication protocol that can be used to monitor any network-connected device via a simple control language and display the results in an application running within a standard web browser.

The PowerWAVE 6000 contains two SNMP slots; one is designed to house a Modem/Ethernet SNMP adapter card and the other a Modem/GSM adapter. Alternatively, SNMP connectivity can also be implemented using an external SNMP adapter connected to the UPS RS232 output.

An SNMP/Ethernet adapter contains an RJ-45 connector which allows it to be connected to the network using a standard network cable. Once connected, the UPS-Management software agent, which is already installed in the SNMP adapter, then monitors the UPS operating parameters. In a multi-module UPS system the SNMP interface can communicate 'system-wide' data or data for an individual UPS module.

The SNMP card enables event/alarm emails, server shutdown (with optional licenses) and other tasks. The SNMP card can also be integrated with BMS software over a local area network (LAN) for SNMP or Modbus information over IP. An optional card enables Modbus comms over RS485.

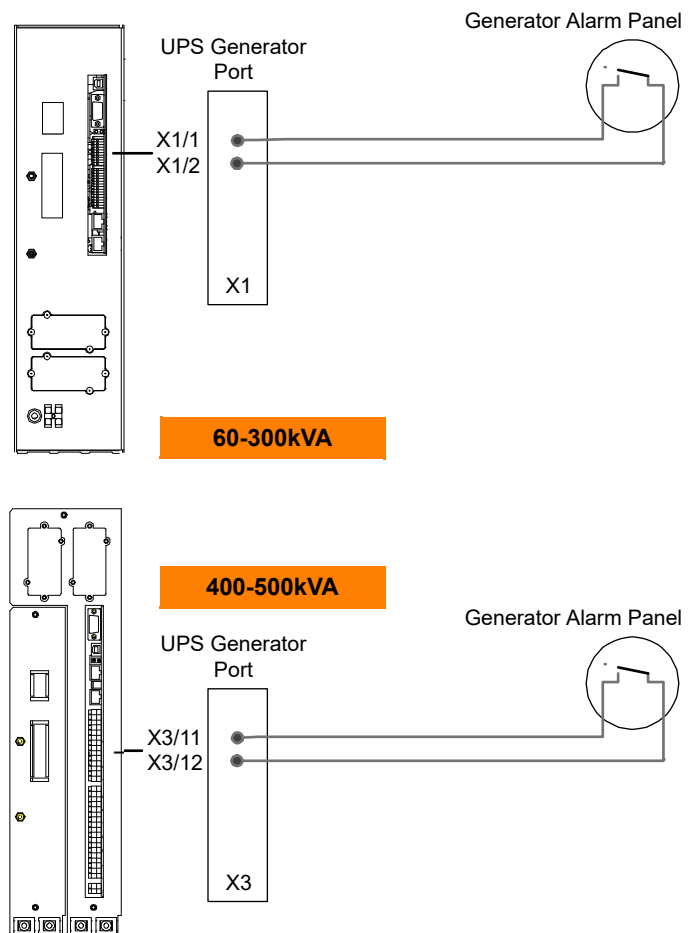

Figure 8.4 Generator ON Connection

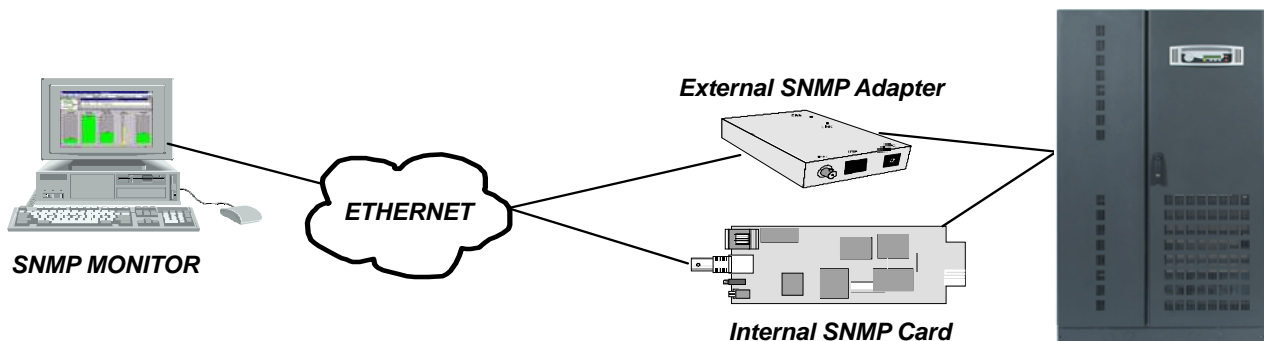

Figure 8.5 SNMP Internal and external adapters

8.4.6 WAVEMON Shutdown and monitoring software (instead of SNMP card)

WAVEMON is designed to operate in conjunction with many of the systems supplied by Uninterruptible Power Supplies Ltd. and features both UPS monitoring and automatic UPS/server shutdown facilities.

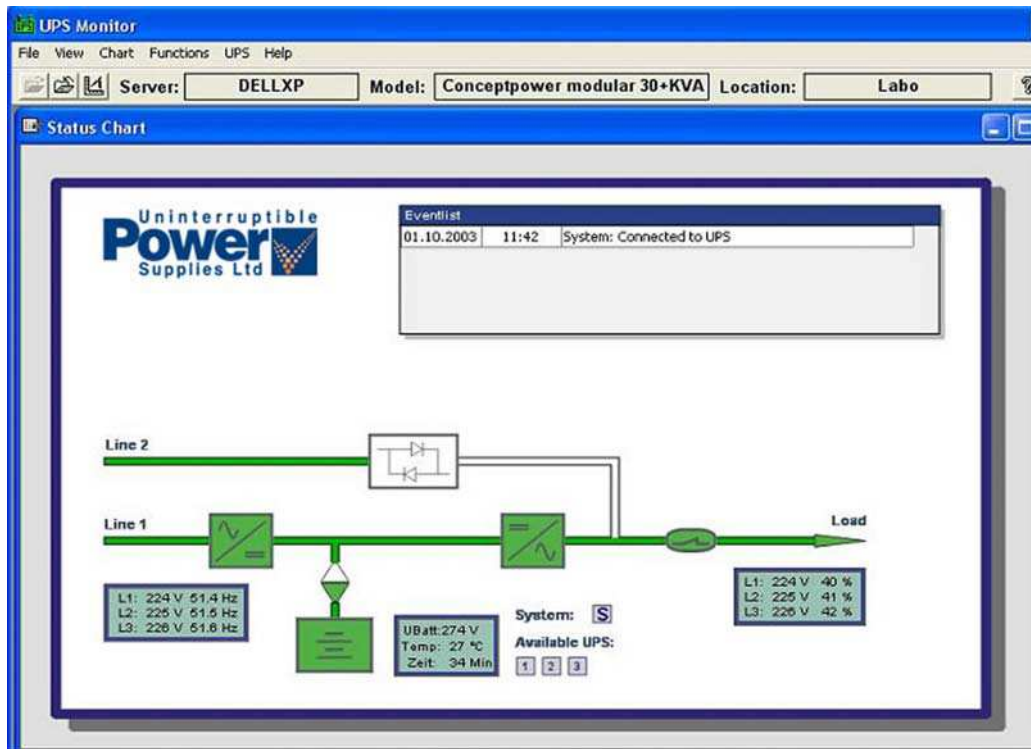

Figure 8.6 Monitoring screen image

WAVEMON comprises a bespoke software package which is installed on a local PC and communicates with the UPS via USB or a standard RS232 serial cable of up to 15m in length. It is only required when an SNMP card or adapter box is not purchased.

The main features of WAVEMON are:

- On-screen autonomy time/battery time countdown.
- On-screen server log-off and shutdown procedure.
- Time and date stamp event log.
- Extensive logging of all UPS activity and power quality data.
- Permits alarm warnings to be monitored remotely via email.
- Scheduled UPS service mode and other systems status.
- Graphical user interface for Windows-compatible platforms.
- Automatic unattended local shutdown.
- Special modules for MS-Office software to close and save open documents.
- Compatible with all optional modules like UPSDIALER, SNMP adaptors, temperature sensors, etc.

Functional description

WAVEMON is a client/server software application for networks and local workstations. In general, it consists of two parts: the server module of the UPS management software is *UPSMAN*, which communicates with the UPS via an RS232/USB interface. Running as a background application, *UPSMAN* collects and interprets the messages received from the UPS and places them at the disposal of the client module *UPSMON*, as well as any connected SNMP-based instrumentation and control system.

If *UPSMAN* detects voltage variations or a power failure, it can execute various 'system event' routines, by means of which, for example, the server is switched off or a warning/alarm is sent to the connected users. These 'system event' routines are a part of the management software and can be configured in to suit local application requirements.

The software of your PowerWAVE 6000 UPS unit can be integrated into a network in two ways:

1. By the server which is supplied by the UPS itself and has been integrated into the network. In most cases this server is used as a sub-agent and you only need the WAVEMON software (without an SNMP adapter). You will also need to establish an RS232/USB connection between the UPS and computer/server.
2. In many cases the use of what is referred to as an 'SNMP adapter' is to be preferred in order to integrate the UPS into the network. In this case up to 50 computers can be shut down in one RCCMD environment. RCCMD (remote console command) is an additional software module that is used in order to execute a command (typically a shutdown command) in a remote system.

Licensing

A licence is issued with every software serial number for use of what is known as the 'UPS service' on a single server in connection with one UPS and an unlimited number of connected WINDOWS workstations. For operation with two or more servers, a further licence is required for each additional server. In this case it is of no importance whether the UPS service on these servers is active or whether the server was stopped by a remote UPS service. The same applies to the use of RCCMD with the 'remote send/receive' modules for 'multi-server shutdown' under NT, UNIX and other operating systems.

The service programs are generally supplied as single licences. In order to use a single CD-ROM for several 'multi-server shut-down' units you must acquire additional licence codes.

RCCMD Server shutdown

In order that remote shutdown of servers can take place, initiated by the SNMP card or WAVEMON software, further licenses must be purchased. The license is for the RCCMD client (or listening) software that resides in each target server.

8.5 PowerREPORTER™ management software

PowerREPORTER is a remote monitoring and management service which provides peace-of-mind protection by offering a continuous (24/7/365) watch over mission-critical facilities. Continuous monitoring is an affordable insurance policy to detect issues and provide an early warning before they develop into a crisis.

The main features and benefits offered by PowerREPORTER are:

- Real time email notification sent directly to UPSL Service Centre in response to alarm/critical events.
- Acquisition of key performance data and productivity information. Empowers you with the details needed to better understand machine performance and quickly troubleshoot downtime events.
- Combined with a service contract, PowerREPORTER improves service levels. The engineer can determine if site attendance is necessary and bring relevant spare parts.
- Monthly Status Report detailing trends and alarms.
- Optional battery analysis and care service; PowerNSURE - measures battery voltage, temperature, impedance and prolongs battery service life through the application of battery charge equalization.

8.5.1 Functional description

PowerREPORTER communicates constantly with your UPS system in order to automatically detect any error or alarm messages. In the event of an incident being detected, PowerREPORTER automatically connects with UPS Limited Service Centre via an email, transmitting a status message.

The email, which provides details relating to the fault, a snapshot of the UPS performance parameters and a device identification string, is automatically processed and UPS Limited Service Centre personnel are alerted.

UPS Limited Service Centre personnel are then able to liaise with the company's field service team and will remotely diagnose the UPS incident before reaching the facility with appropriate spare parts within the contracted service agreement time-frame.

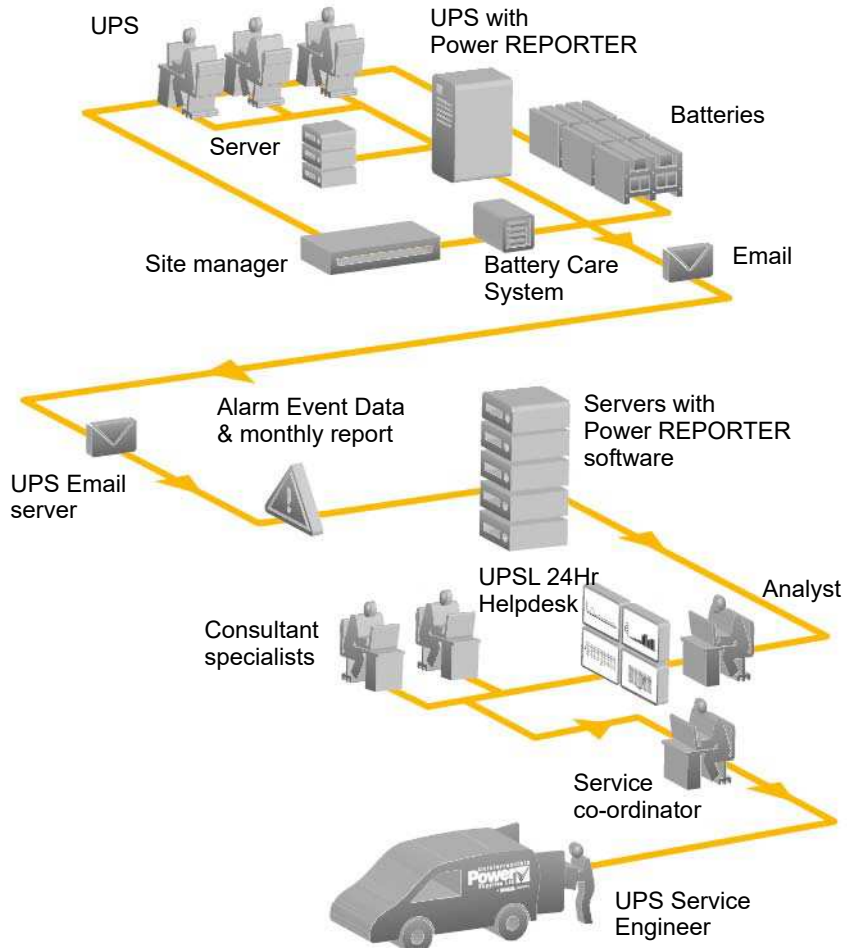



Figure 8.7 PowerREPORTER operation

9 Specifications

9.1 General specifications

MECHANICAL CHARACTERISTICS 60-100kVA (No Battery Enc.)					
		Rating (kVA)	60	80	100
Dimensions (WxHxD)	mm		550 x 1820 x 750		
Dimensions with elevation kit (WxHxD)	mm		550 x 1975 x 750		
Weight	kg		205	225	230
Colour			Graphite Grey (RAL 7024)		
Batteries			Fitted in external enclosure		
Input and output power cable entry			Bottom		
Exhaust cooling air			Rear		



MECHANICAL CHARACTERISTICS 60-100kVA (Battery Enc. A)					
		Rating (kVA)	60	80	100
Dimensions (WxHxD)	mm		970 x 1820 x 750		
Dimensions with elevation kit (WxHxD)	mm		970 x 1975 x 750		
Weight without batteries fitted	kg		250	260	285
Weight with 80 x 28Ah batteries fitted	kg		1140	1150	1175
Colour			Graphite Grey (RAL 7024)		
Batteries (Max configuration)			80 x 28Ah Battery blocks mounted on 16 shelves.		
Input and output power cable entry			Bottom		
Exhaust cooling air			Rear		



MECHANICAL CHARACTERISTICS 60-100kVA (Battery Enc. B)				
Rating (kVA)		60	80	100
Dimensions (WxHxD)	mm	1180 x 1820 x 750		
Dimensions with elevation kit (WxHxD)	mm	1180 x 1975 x 750		
Weight without batteries fitted	kg	260	270	295
Weight with 120 x 28Ah batteries fitted	kg	1590	1600	1625
Colour		Graphite Grey (RAL 7024)		
Batteries (Max configuration)		120 x 28Ah Battery blocks mounted on 24 shelves.		
Input and output power cable entry		Bottom		
Exhaust cooling air		Rear		



MECHANICAL CHARACTERISTICS 120-200kVA				
Rating (kVA)		120	160	200
Dimensions (WxHxD)	mm	850 x 1820 x 750		
Dimensions with elevation kit (WxHxD)	mm	850 x 1975 x 750		
Weight	kg	280	290	310
Colour		Graphite Grey (RAL 7024)		
Batteries		Fitted in external enclosure		
Input and output power cable entry		Bottom		
Exhaust cooling air		Rear		



MECHANICAL CHARACTERISTICS 250-300kVA				
Rating (kVA)		250	300	
Dimensions (WxHxD)	mm	1100 x 1920 x 750		
Dimensions with elevation kit (WxHxD)	mm	1100 x 1975 x 750		
Weight	kg	390	410	
Colour		Graphite Grey (RAL 7024)		
Batteries		Fitted in external enclosure		
Input and output power cable entry		Bottom		
Exhaust cooling air		Rear		



9: Specifications

MECHANICAL CHARACTERISTICS 400-500kVA			
Rating (kVA)		400	500
Dimensions (WxHxD)	mm	1650 x 1994 x 850	
Dimensions with elevation kit (WxHxD)	mm	1650 x 2094 x 850	
Weight	kg	950	1000
Colour		Graphite Grey (RAL 7024)	
Batteries		Fitted in external enclosure	
Input and output power cable entry		Bottom	
Exhaust cooling air		Top	



MECHANICAL CHARACTERISTICS 400-500kVA (with TCE cabinet)			
Rating (kVA)		400	500
Dimensions (WxHxD)	mm	2150 x 1994 x 850	
Dimensions with elevation kit (WxHxD)	mm	2150 x 2094 x 850	
Weight with TCE basic	kg	950+115	1000+115
Weight with TCE single input feed + cables	kg	950+245	1000+245
Weight with TCE dual input feed + cables	kg	950+285	1000+285
Colour		Graphite Grey (RAL 7024)	
Batteries		Fitted in external enclosure	
Input power cable entry		Top	
Output power cable entry		Bottom	
Exhaust cooling air		None	



OUTPUT CHARACTERISTICS		60	80	100	120	160	200	250	300	400	500
Output rated power (@min 44 battery blocks)	kW	60	80	100	120	160	*200	250	300	400	500
Output current In (PF=1.0) (@min 44 battery blocks)	A	87	116	145	174	232	*290	361	433	577	722
Output rated voltage	V	3x 380/220 or 3x 400/230 or 3x 415/250									
Output voltage stability (Static)	%	< ± 1.0									
Output voltage stability (Dynamic)	%	< ±4 (with load step 0-100%, 100-0%)									
Output voltage distortion with linear load	%	< 2 with linear load									
Output voltage distortion with non-linear load	%	< 4 (EN 62040-3:2001)									
Output frequency	Hz	50 or 60									
Output frequency tolerance	%	±0.1 free-running, quartz oscillator ±2 or ±4 with mains synchronised (selectable)									
Frequency slew rate	Hz/s	1.0									
Output waveform		Sinewave with 0deg. phase imbalance @100% unbalanced load									
Permissible unbalanced load	%	100% (all 3 phases independently regulated)									
Overload capability on inverter	%	At PF=1.0 110% load for 10 minutes At PF=1.0 135% load for 1 minute At PF=0.9 125% load for 10 minutes At PF=0.9 150% load for 1 minute									
Inverter short circuit capability (x rated output for 40ms)	A	2.7x	2.0x	2.3x	1.8x	1.9x	2.1x	1.8x	2.0x	2.0x	2.0x
Bypass short circuit capability		10x rated In for 10ms									
Crest factor		3:1									
Bypass operation		At ±15.0% of nominal input voltage									
* With 50 battery blocks only											

OUTPUT POWER VERSUS COS Ø		Inductive (lagging COS Ø)								Unity	Capacitive (leading COS Ø)			
Module		0.6	0.65	0.7	0.75	0.8	0.85	0.9	0.95	1.0	0.95	0.9	0.85	0.8
60	kVA	60	60	60	60	60	60	60	60	60	60	60	59	58
	KW	36	39	42	45	48	51	54	57	60	57	54	50	46
80	kVA	80	80	80	80	80	80	80	80	80	80	80	78	77
	KW	48	52	56	60	64	68	72	76	80	76	72	66	61
100	kVA	100	100	100	100	100	100	100	100	100	100	100	98	97
	KW	60	65	70	75	80	85	90	95	100	95	90	83	77
120	kVA	120	120	120	120	120	120	120	120	120	120	120	117	116
	KW	72	78	84	90	96	102	108	114	120	114	108	100	92
160	kVA	160	160	160	160	160	160	160	160	160	160	160	156	154

OUTPUT POWER VERSUS COS Ø														
200*	KW	96	104	112	120	128	136	144	152	160	152	144	132	122
	kVA	200	200	200	200	200	200	200	200	200	200	200	195	194
250	KW	120	130	140	150	160	170	180	190	200	190	180	166	154
	kVA	250	250	250	250	250	250	250	250	250	250	250	245	241
300	KW	150	163	175	188	200	213	225	238	250	238	225	208	192
	kVA	300	300	300	300	300	300	300	300	300	300	300	294	291
400	KW	180	195	210	225	240	255	270	285	300	385	270	249	231
	kVA	400	400	400	400	400	400	400	400	400	400	400	392	388
500	KW	240	260	280	300	320	340	360	380	400	380	360	333	310
	kVA	500	500	500	500	500	500	500	500	500	500	500	490	485
	KW	300	325	350	375	400	425	450	475	500	475	450	417	338

*Vout=230Vac (L-N), 50 Hz, with minimum of 44 battery blocks (*50 Battery blocks on 200kVA model)*

ENVIRONMENTAL CHARACTERISTICS		60	80	100	120	160	200	250	300	400	500
Audible noise @ 100/50% load	dBA	< 65			< 69			< 71		N/A	
Ambient temperature for UPS	°C	0-40									
Ambient temperature for batteries (recommended)	°C	20									
Battery storage time at ambient temperature		Maximum 6 months									
Fan assisted cooling air flow		Front entry, rear exit								Front entry top exit	
Airflow (25 - 30°C) with 100% non-linear load	m³/h	1300	1500	1700	2500			3350		6550	
Heat dissipation with 100% non-linear load	W	3830	5106	6368	7660	10213	12766	15957	19149	24000	30000
Heat dissipation with 100% non-linear load	BTU/h	13071	17428	21785	26142	34856	43570	54462	65355	81913	102389
Heat dissipation without load	W	850			1500			2300		4000	
Relative air-humidity		Maximum 95% (non-condensing)									
Max altitude above sea level without derating		1000m (3300ft) without derating									
De-rating factor for use at altitudes above 1000m sea level according (IEC 62040-3)		Height above sea level (m/ft)					Derating factor for power				
		1500 / 4850					0.95				
		2000 / 6600					0.91				
		2500 / 8250					0.86				
		3000 / 9900					0.82				

STANDARDS	
Safety	EN62040-1-1:2003 EN60950-1:2001/A11;/2004
Electromagnetic compatibility	IEC/EN 62040-2:2005, IEC/EN61000-3-2:2000, IEC/EN61000-6-2:2001,
Performance	EN 62040-3:2001
Product certification	CE
Degree of protections	IP20

COMMUNICATION OPTIONS	
Power Management Display (PMD)	LCD display and mimic diagram showing UPS operational status (Optional 7" TFT touchscreen display standard on 400/500kVA model)
Customer Interfaces: (Dry Ports)	Volt-free output interface provide status and alarm outputs for remote indication and interfacing with BMS systems. Together with customer inputs interface for connecting an Emergency Stop, On Generator status etc.
RS232 on Sub-D9 port RS232 on USB port	For monitoring and integration in network management
RS485 on RJ45 port	Remote monitoring system with graphical display (option)
RS485 on RJ45 port	For multidrop purposes (option)
Slot for SNMP Card	Ethernet card for monitoring and integration in network management (option)
Slot for SNMP Card	Modem card for GSM remote monitoring (option)

9.2 60-300kVA Fuses & cables quick reference

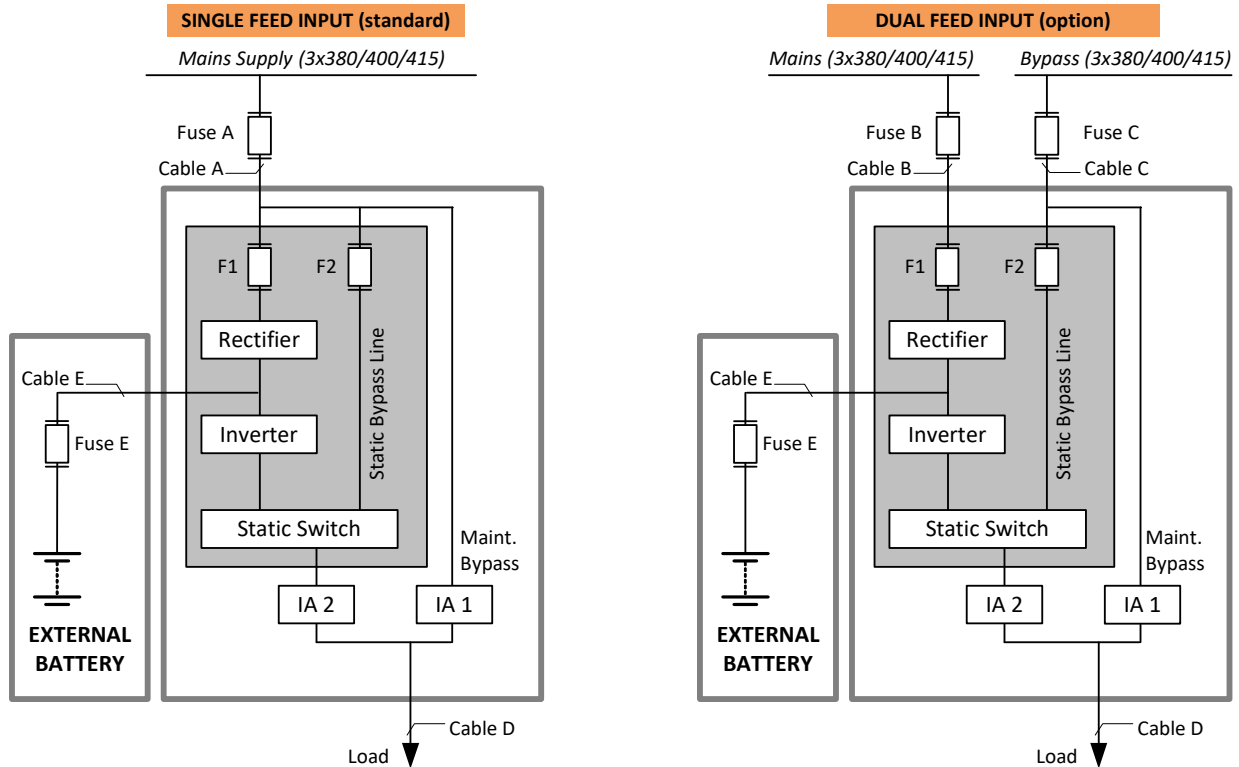

Single feed input

Power (kVA)	Fuse A (Agl/CB)	Cable A	Cable D
60	3x100	5x35	5x35
80	3x125	5x50	5x50
100	3x160	5x50	5x50
120	3x200	5x70	5x70
160	3x250	5x120 or 5x(2x50)	5x120 or 5x(2x50)
200	3x315	5x185 or 5x(2x70)	5x185 or 5x(2x70)
250	3x400	5x240 or 5x(2x95)	5x240 or 5x(2x95)
300	3x500	5x(2X120)	5x(2X120)

Dual feed input

Power (kVA)	Fuse B (Agl/CB)	Cable B	Fuse C (Agl/CB)	Cable C	Cable D
60	3x100	5x35	3x100	5x35	5x35
80	3x125	5x50	3x125	5x50	5x50
100	3x160	5x50	3x160	5x50	5x50
120	3x200	5x70	3x200	5x70	5x70
160	3x250	5x120 or 5x(2x50)	3x250	5x120 or 5x(2x50)	5x120
200	3x315	5x185 or 5x(2x70)	3x315	5x185 or 5x(2x70)	5x185
250	3x400	5x240 or 5x(2x95)	3x400	5x240 or 5x(2x95)	5x240 or 5x(2x95)
300	3x500	5x(2x120)	3x500	5x(2x120)	5x(2x120)

9.3 400-500kVA Fuses & cables quick reference

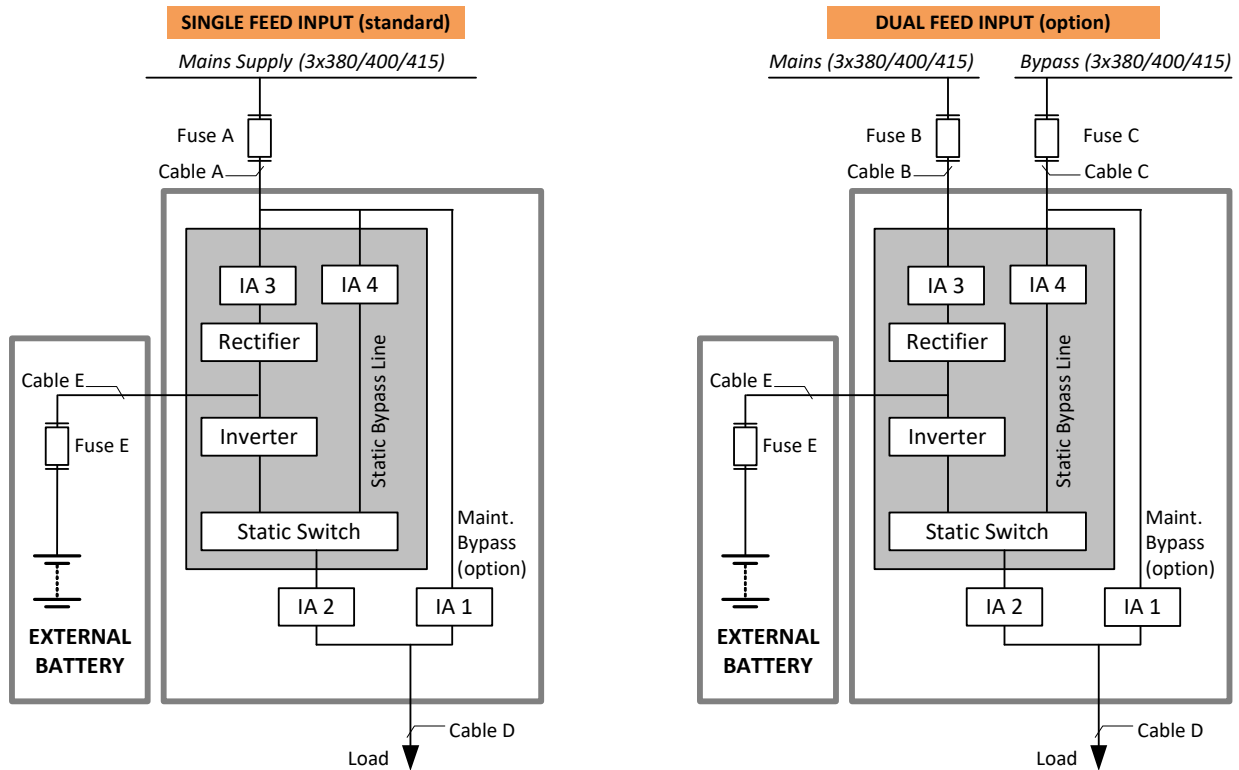

Single feed input

Power (kVA)	Fuse A (Agl/CB)	Cable A	Cable D
400	3x630	5x (3x95) or 5x (2x185)	5x (3x95) or 5x (2x185)
500	3x800	5x (3x150)	5x (3x150)

Dual feed input

Power (kVA)	Fuse B (Agl/CB)	Cable B	Fuse C (Agl/CB)	Cable C	Cable D
400	3x630	5x(3x95) or 5x(2x185)	3x630	5x (3x95) or 5x(2x185)	5x(3x95) or 5x(2x185)
500	3x800	5x (3x150)	3x800	5x50	5x(3x150)

Note: Battery cabling (Cable E) and battery fuses (Fuse E) are bespoke to the installation